

Jean-Edouard Cistacq

HOSSA

Lamps - 2023



eno
studio
—



eno
studio_

Jean-Edouard Cistacq

TORIN

Wall lamp - 2023

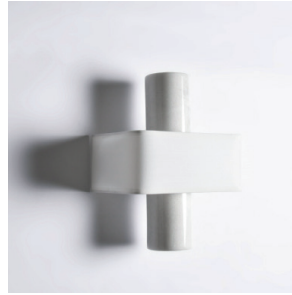

Material & Finish



Marbre beige / Beige marble
JE01EN001000



Passepoil marron / Brown piping
JE01EN002000



Marbre noir / Black marble
JE01EN001010



Passepoil blanc / White piping
JE01EN002020



Marbre vert / Green marble
JE01EN001030



Passepoil noir / Black piping
JE01EN002010



Marbre blanc / white marble
JE01EN001020

Marbre & tissu /
marble & fabric

Dimensions & weight

Dimension / Size :
Poids / Weight

31 cm x 15 cm x 23 cm
5 kg

Other details

Luminaire d'intérieur dimmable /
Indoor dimmable lamp only
IP20
G9 bulb not included

G9
220-240 V
50 Hz

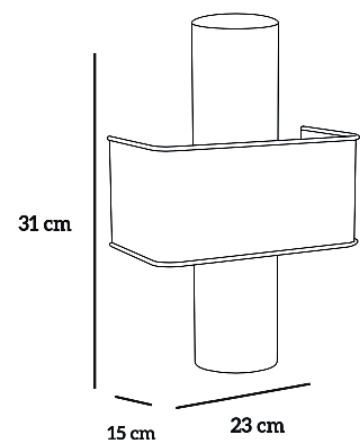

Entretien / Cleaning

Utiliser un chiffon doux et ne
pas utiliser de produit abrasif.

Use a clean and soft cloth. Do
not use any abrasive product.



Jean-Edouard CISTACQ

Jean-Edouard Cistacq est diplômé de l'Ecole Supérieure des Art & Design de Saint Etienne (ESADSE).

En 2014 il intègre la galerie Kréo où il travailla avec des grands noms du design comme konstantin Grcic, r&e Bouroullec, Hella Jongerius. Il devient en 2016 le directeur artistique d'ENO studio et fait évoluer la marque dans le domaine du luminaires avec des designs impactants et modernes.

/

Jean-Edouard Cistacq graduated from the Higher School of Art and Design in Saint Etienne (ESADSE). In 2014, he joined the Kréo gallery where he worked with major design names such as Konstantin Grcic, Ronan and Erwan Bouroullec, and Hella Jongerius. In 2016, he became the artistic director of ENO studio and developed the brand's impact and modern lighting designs.



HOSSA

Lamp - 2023

L'applique HOSSA est une alliance entre une carotte de marbre et la finesse d'un abat jour en coton naturel. Elle saura donner une touche de raffinement à tous les intérieurs.



/

HOSSA wall lamp is the mix between natural marble and the coton. It will be the master piece of all the rooms.

Other creations with
ENOsudio :



eno studio

ENOstudio

Bureau & showroom

40 rue Sainte-Croix-de-la-Bretonnerie

75004 Paris

T +33 (0)1 45 31 31 76

enostudio.fr