

TECHNICKÝ LIST

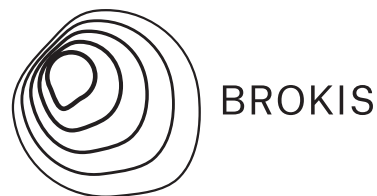

BROKIS

Název	Závěsné svítidlo
Typ	Whistle
ID	PC961
Popis	Kolekce Whistle je doslova živoucím odkazem na práci sklářů, neboť právě sklářské píšťaly byly inspirací při jejím zrodu. Průzračné tělo lampy opisuje siluetu kuželu světla a jeho pomyslné srdce tvoří světelný zdroj v podobě bodového reflektoru.
Technický popis	Svítidlo je sestaveno ze skleněného těla s přípojovacím Brokis konektorem a s přípojovacím kabelem s konektorem. Ve spodní části je v kovovém reflektoru umístěna objímka GX53. Svítidlo je zavěšeno na stropním baldachýnu.



KONSTRUKČNÍ SPECIFIKACE

Hmotnost [kg]	18 kg
Použité materiály	sklo, kov
délka přípojovacího vodiče [mm]	2,000 mm
Montáž	Strop
Prostředí	Vnitřní

Rozměr [mm]

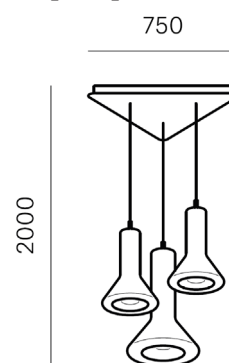

ELEKTRICKÁ SPECIFIKACE

Jmenovité napětí [V]	230 VDC
Frekvence [Hz]	50-60 Hz
Max. příkon [W]	3 x 15W LED
Krytí IP	20
Patice	3 x GX53
Světelný zdroj	-
Energetická třída	A+ až B dle použitého zdroje

Certifikace



TECHNICKÝ LIST

DOPORUČENÉ SVĚTELNÉ ZDROJE

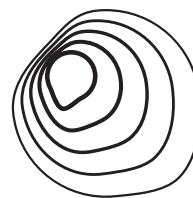

BROKIS



LAMPIA GX53 10W

Patice	GX53
Typ	LED
Příkon [W]	10 W
Vstupní napětí [V]	220 - 240 VAC
Energetická třída	A+
Světelný tok [lm]	700 lm
Barevná teplota [K]	2700 K
CRI	90+
Životnost [h]	25000 h
Stmívatelnost	ano
Rozměry v x š [mm]	39 x 90 mm

STROPNÍ BALDACHÝN

Rozměry ax v [mm]	750 x 50 mm
Hmotnost [kg]	7.9 kg
Materiál	kov

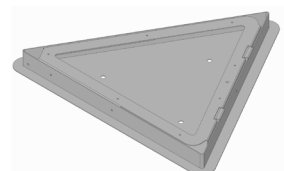

Nákres

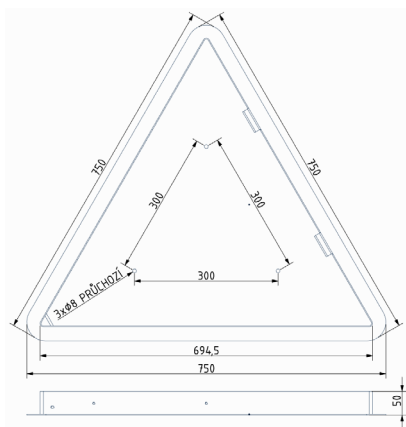

Držák baldachýnu

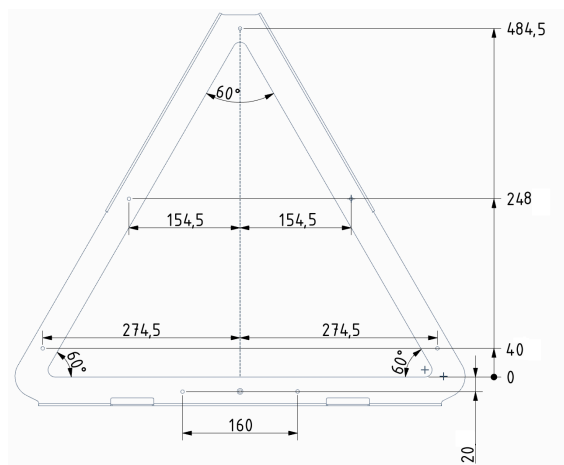

DATASHEET



BROKIS

Name Pendant lamp

Type Whistle

ID PC961

Description The Whistle collection is, quite literally, a living reference to the work of glassmakers, as inspiration for the design was taken from the blowpipe, which in Czech is known as a glassmaker's whistle. The lucid body of the piece traces the silhouette of a cone of light, and a distinct spotlight with hand-pressed metal shield constitutes its imaginary heart.

Tech. description The light consists of a glass body with Brokis connector and lead cable with connector. The bottom section comprises a metal reflector with GX53 light source socket. The light includes a metal ceiling canopy.



CONSTRUCTION SPECIFICATION

Weight [kg]	18 kg
Construction material	glass, metal
Cord length [mm]	2,000 mm
Mounting	Ceiling
Environment	Indoor

ELECTRICAL SPECIFICATION

Input voltage [V]	230 VDC
Frequency [Hz]	50-60 Hz
Max. power [W]	3 x 15 W
Coverage IP	20
Socket	3 x GX 53
Light source	-
Energy class	A+ to B depending on light source

Dimensions [mm]

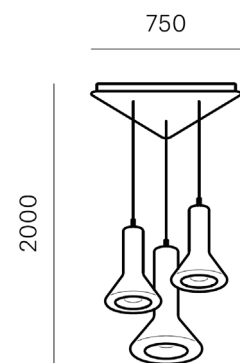

Certifications



DATASHEET

RECOMMENDED BULBS

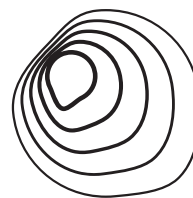

BROKIS



LAMPIA GX53 10W

Socket	GX53
Type	LED
Lamp wattage [W]	10 W
Input voltage [V]	220 - 240 VAC
Energy class	A+
Flux[lm]	700 lm
Light Colour [K]	2,700 K
CRI	90+
Lifespan [h]	25,000 h
Dimmable	yes
Dimensions h x w [mm]	39 x 90 mm

Ceiling Canopy

Dimensions a x v [mm]	750 x 50 mm
Weight [kg]	7.9 kg
Material	metal

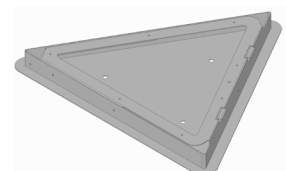

Drawing

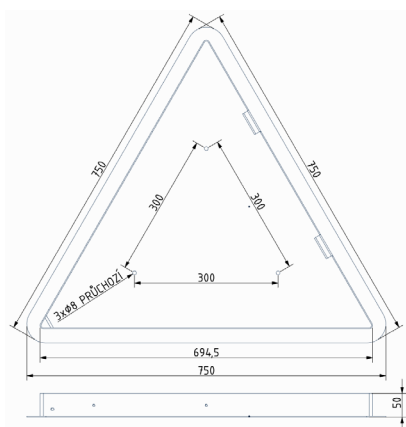

Canopy bracket

