

## lui piano pro datasheet

LED ceiling recessed spotlight with cylindrical head and replaceable optics; mounting flush with ceiling for hollow ceilings or solid ceilings with ceiling box. Thanks to the ball joint principle, the head is freely rotatable (with stop) and pivotable by 45° on the horizontal axis using a joint integrated into the tube. Version with remote power supply unit; connection to external power source (driver). Dimmable via customer-supplied dimmable power supply unit. Choice of several variants for different installation solutions. Covers that are held in place magnetically are used in ceiling-mounted versions and in frameless models which either have a mounting plate or are mounted on panels that are accessible from the rear (used in hollow ceilings). There are two optics to choose from: The zoom optic, which offers a continuous beam of light that can be set from 20° to 60°, and the lens optic, which has an internal lens combined with various inserts. The optics and optical components can be replaced without any tools, using a simple mechanism. The Occhio LED is replaceable.

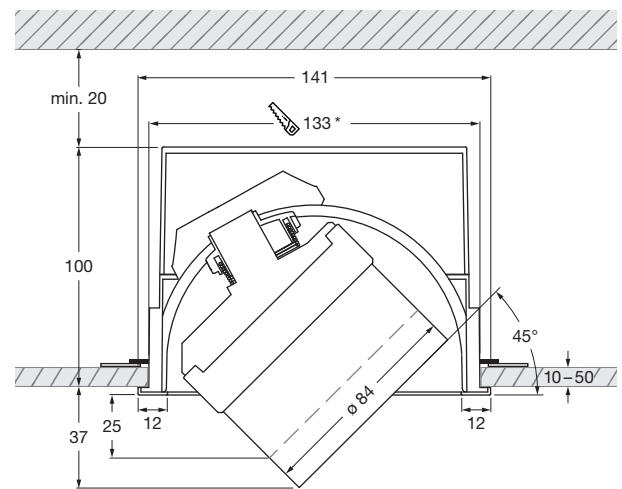
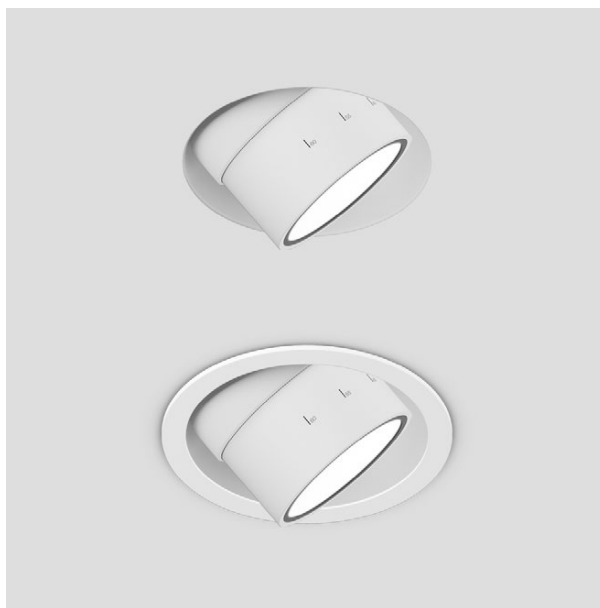

\* cut-out dimensions  
Installation depth: 120 mm  
dimensions in mm

### technical data lui piano pro

properties	material	aluminium, steel chrome-plated, painted or anodised, plastic, glass, optical plastic	
	turning range light unit	360° (with stop)	
	movability head	45° (with stop)	
	weight	1.1 kg	
surface	head	shiny chrome, matt white, matt black	
	optic	matt gold, rose gold, bronze, shiny chrome, matt chrome, matt white, matt black, phantom, black phantom	
	cover	matt gold, rose gold, bronze, shiny chrome, matt white, matt black, phantom, black phantom	
	tube	matt white, matt black	
Occhio LED	average life time	> 50.000 hrs	
	energy efficiency class (luminous efficiency)	G (zoom optic 58 lm/W, lens optic 66 lm/W)	
	power	LED 18 W	
	color rendering index	perfect color; CRI Ra 97	high flux; CRI Ra 85
	color temperature	2700 K, 3000 K	3000 K, 3500 K, 4000 K
electricity	dimming	dimmable with suitable power supply unit	
	power supply unit	max. 500 mA const./ > 36 V DC	
	permitted operating conditions	max. 30°C for indoor use only	

## lui piano pro mounting options

### lui piano pro

ø head 94 mm, H 99 mm (zoom lens),  
H 85 mm (lens optic)  
45° swivel angle, 360° rotatability

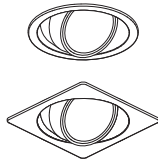

### mounting tube with cover

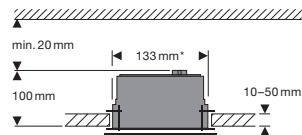

hollow ceiling



cover

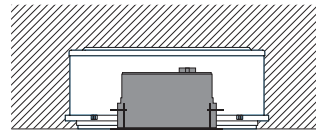

concrete ceiling  
(Kaiser HaloX 250 with mineral-fibre board)  
driver max. L 210 mm × W 30 mm

### lui piano pro pure

ø head 94 mm, H 99 mm (zoom lens),  
H 85 mm (lens optic)  
45° swivel angle, 360° rotatability

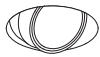

### flush-mount ring for seamless mounting

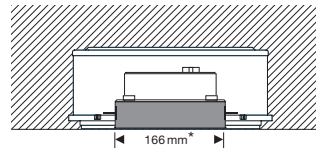

concrete ceiling plastered, no fair-faced concrete  
(Kaiser HaloX 250 with mineral-fibre board)  
driver max. L 210 mm × W 30 mm

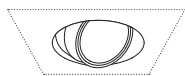
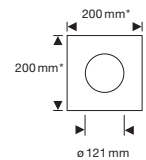

### mounting board for seamless mounting

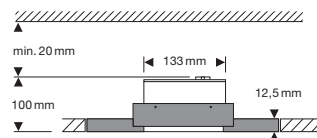

hollow ceiling  
(mineral-fibre board with holding ring)

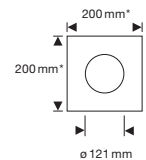

\*cut-out dimensions

## lui piano pro overview inserts

	zoom	C 80	C 60	S 80	S 60	S 40	S 30
lui head							
zoom optic							
lens optic							
small lens medium							
small lens high							
soft edge glass							
clear glass							
fresnel lens							
	zoom	80°, contour	60°, contour	80°, soft	60°, soft	40°, soft	30°, soft

## lui piano pro lighting effects

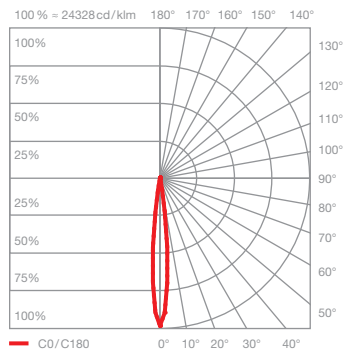
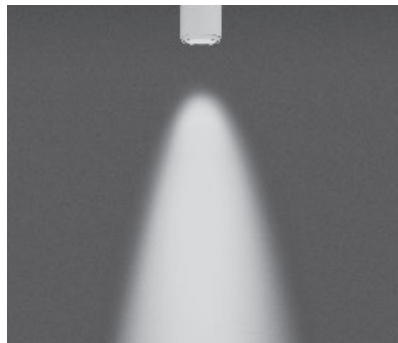

### Z20 soft

directed light with soft contour beam angle (approx. 20°)

inserts: zoom lens  
soft edge glass

luminous flux: perfect color 18W 890lm  
high flux 18W 1190lm

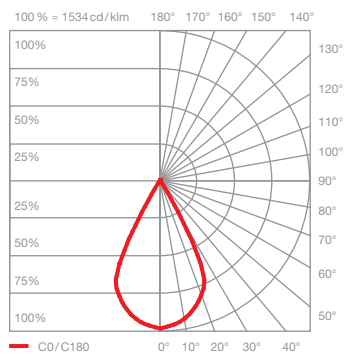
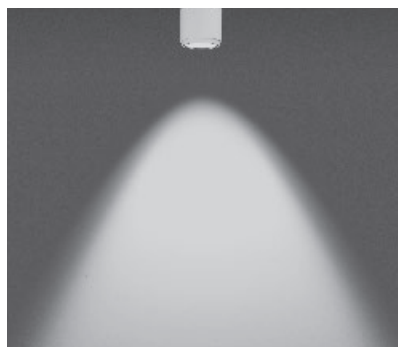

### Z60 soft

directed light with soft contour beam angle (approx. 60°)

inserts: zoom lens  
soft edge glass

luminous flux: perfect color 18W 890lm  
high flux 18W 1190lm

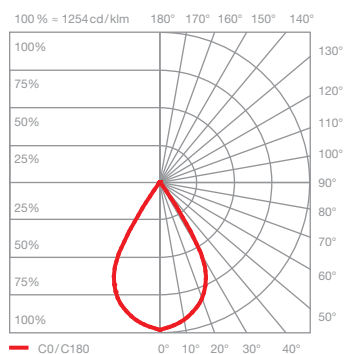
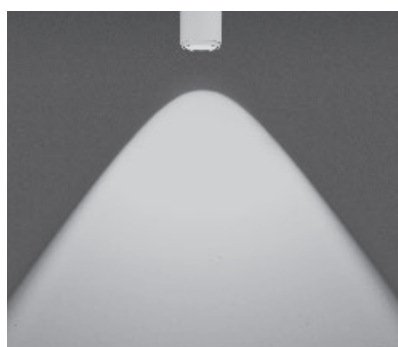

### C80 contour

directed light with contour beam angle (approx. 80°)

inserts: lens optic  
small lens medium  
clear glass

luminous flux: perfect color 18W 1010lm  
high flux 18W 1350lm

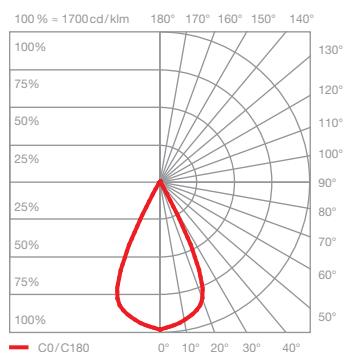
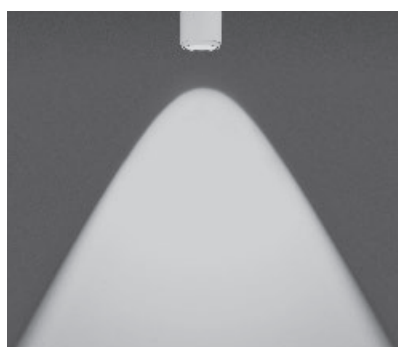

### C60 contour

directed light with contour beam angle (approx. 60°)

inserts: lens optic  
small lens high  
clear glass

luminous flux: perfect color 18W 1040lm  
high flux 18W 1390lm

## lui piano pro lighting effects

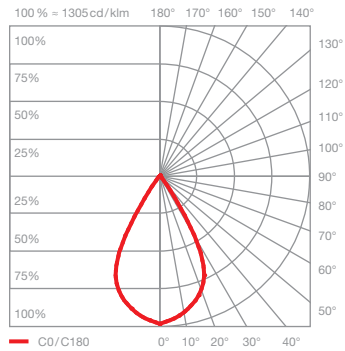

### S80 soft

directed light with soft contour beam angle (approx. 80°)

inserts: lens optic  
small lens medium  
soft edge glass

luminous flux: perfect color 18W 1010lm  
high flux 18W 1340lm

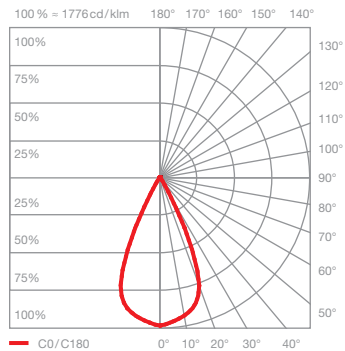
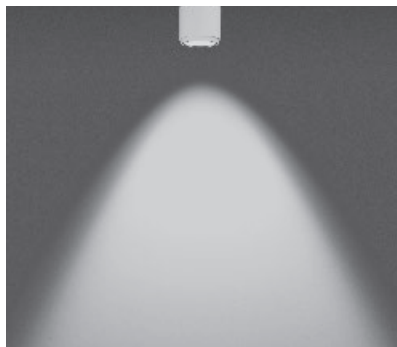

### S60 soft

directed light with soft contour beam angle (approx. 60°)

inserts: lens optic  
small lens high  
soft edge glass

luminous flux: perfect color 18W 1010lm  
high flux 18W 1350lm

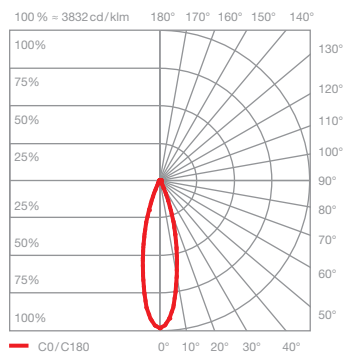
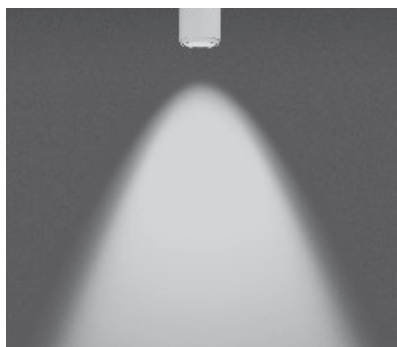

### S40 soft

directed light with soft contour beam angle (approx. 40°)

inserts: lens optic  
small lens medium  
fresnel lens

luminous flux: perfect color 18W 910lm  
high flux 18W 1210lm

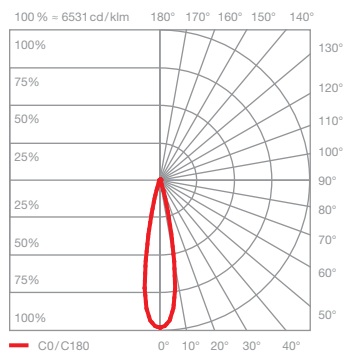
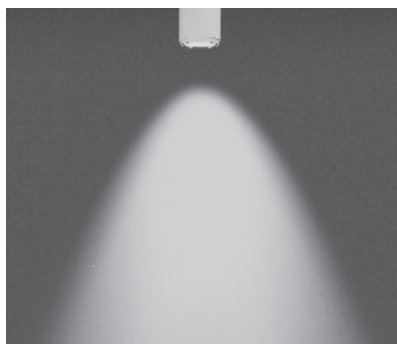

### S30 soft

directed light with soft contour beam angle (approx. 30°)

inserts: lens optic  
small lens high  
fresnel lens

luminous flux: perfect color 18W 940lm  
high flux 18W 1250lm