

## TECNICA PRO LED

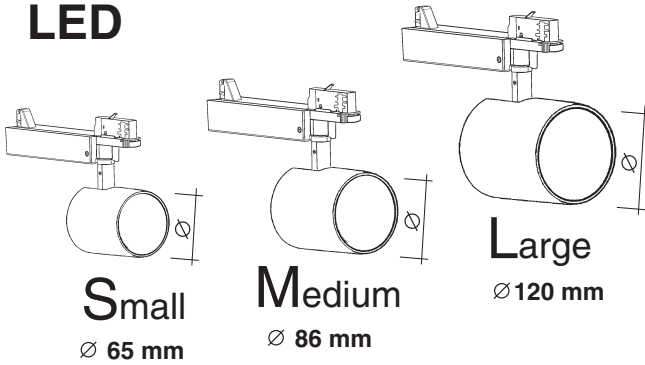

### ATTENZIONE:

LA SICUREZZA DELL'APPARECCHIO E' GARANTITA SOLO CON L'USO APPROPRIATO DELLE SEGUENTI ISTRUZIONI; PERTANTO E' NECESSARIO CONSERVARLE.

### WARNING:

THE SAFETY OF THIS FIXTURE IS GUARANTEED ONLY IF YOU COMPLY WITH THESE INSTRUCTIONS; REMEMBER TO CONSERVE IN A SAFE PLACE.

### ATTENTION:

LA SECURITE DEL L'APPAREIL N'EST GARANTIE QU'EN CAS D'UTILISATION CORRECTE DES INSTRUCTIONS SUIVANTES; IL FAUT PAR CONSEQUENT LES CONSERVER.

### ACHTUNG:

DIE SICHERHEIT DES GERÄTES WIRD NUR DURCH SACHGEMÄSSE BEFOLGUNG NACHSTEHENDER ANWEISUNGEN GEWÄHRLEISTET; IHRE AUFBEWAHRUNG IST DESHALB SEHR WICHTIG.

### OPGELET:

DE VEILIGHEID VAN DI ATOESTEL IS SLECHTS DAN GEGARANDEERD ALS INDIEN DE VOLGENDE INSTRUCTIES STRIKT WORDEN TOEGEPAST; DAAROM MOET MEN ZE OOK BEWAREN.

### ATENCION:

LA SEGURIDAD DEL APARATO SE GARANTIZA SOLO CUMPLIENDO CUIDADOSAMENTE LAS SIGUIENTES INSTRUCCIONES; POR ELLO, ES NECESARIO CONSERVARLAS.

### BEMERK:

SIKKERHEDEN VED BRUG AF ARMATURET KAN KUN GARANTERES, HVIS DISSE ANVISNINGER FØLGES; SØRG DERFOR FOR AT GEMME DEM.

### ADVASEL:

SIKKERHETEN TIL DETTE APPARATET GARANTERES KUN HVIS DU OVERHOLDER DISSE INSTRUKSJONENE; HUSK Å OPPBEVARE DEM PÅ ET TRYGT STED.

### OBSERVERA!

UTRUSTNINGENS SÄKERHET KAN ENDAST GARANTERAS OM DESSA ANVISNINGAR RESPEKTERAS I DETALJ. SPARA DÄRFÖR DESSA ANVISNINGAR FÖR FRAMTIDA KONSULTATION.

### ВНИМАНИЕ:

МЫ ГАРАНТИРУЕМ БЕЗОПАСНУЮ ЭКСПЛУАТАЦИЮ ИЗДЕЛИЯ ТОЛЬКО ПРИ СОБЛЮДЕНИИ СЛЕДУЮЩИХ ИНСТРУКЦИЙ; С ЭТОЙ ЦЕЛЬЮ НЕОБХОДИМО СОХРАНИТЬ ДАННУЮ БРОШЮРУ.

### 警告

为确保该装置安全，请遵守操作指示；并于安全场所放置。

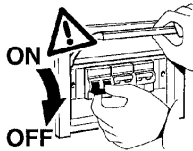

- I Il funzionamento dei prodotti è garantito solo con l'utilizzo di binari ed accessori iGuzzini
- GB Correct product operation is only guaranteed if iGuzzini tracks and accessories are used.
- F Le fonctionnement des produits n'est garanti qu'en cas d'utilisation de rails et accessoires iGuzzini
- D Die Funktion der Produkte ist nur mit dem Einsatz von Schienen und Zubehör iGuzzini gewährleistet
- NL De werking van de producten wordt alleen gegarandeerd bij het gebruik van iGuzzini rails en accessoires.
- E El funcionamiento de los productos se garantiza solamente si se utilizan railes y accesorios iGuzzini.
- DK Produktet er kun garanteret med brug af iGuzzini-skiner og -udstyr.
- N Produktenes korrekte drift garanteres bare ved bruk av spor og tilbehør fra iGuzzini
- S Produkternas funktion garanteras endast vid användning av spår och tillbehör från iGuzzini
- RUS Функционирование продуктов гарантировано только при использовании бинариев и аксессуаров iGuzzini
- CN 此产品的正常运行只有在使用IGUZZINI的轨道及配件的情况下才可以保证

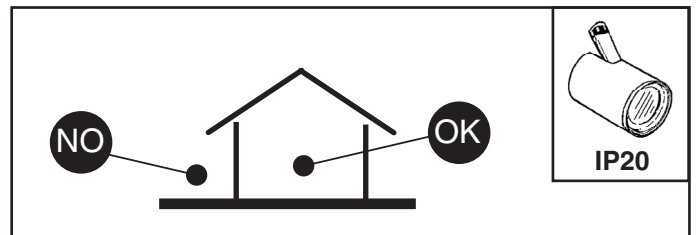
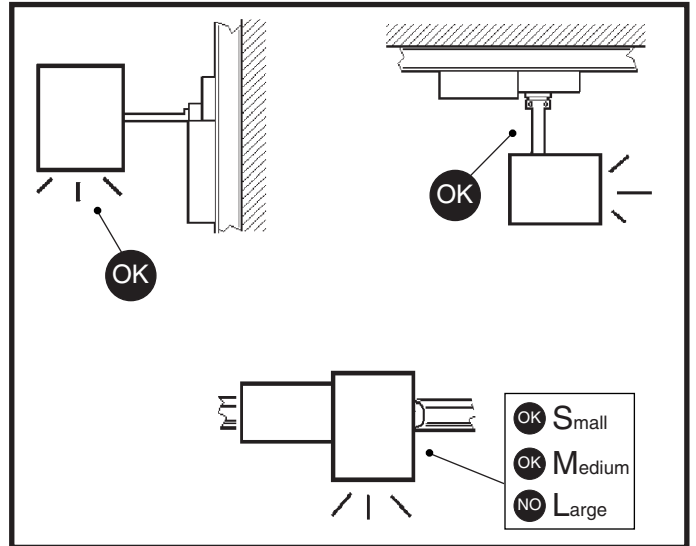

N.B.: DURANTE L'INSTALLAZIONE DEL SISTEMA RISPETTARE SCRUPolosAMENTE LE NORME IMPIANTISTICHE VIGENTI.

N.B.: WHEN INSTALLING THE SYSTEM, STRICTLY COMPLY WITH ALL REGULATIONS ON INSTALLATION IN FORCE.

N.B.: LORS DE L'INSTALLATION DU SYSTÈME VEUILLEZ RESPECTER RIGOREUSEMENT LES NORMES EN VIGUEUR EN LA MATIÈRE.

NB: BEACHTEN SIE BEI DER INSTALLATION DES SYSTEMS GEWISSENHAFT DIE GÜLTIGEN BESTIMMUNGEN BEZÜGLICH DER ANLAGENTECHNIK.

N.B.: BIJ HET INSTALLEREN VAN HET SYSTEEM MOET U DE GELDEN DE INSTALLATIE-NORMEN STRIKT NALEVEN.

N.B.: DURANTE LA INSTALACIÓN DEL SISTEMA RESPETAR E SCRUPolosAMENTE LAS NORMAS DE INSTALACIÓN VIGENTES.

N.B.: UNDER INSTALLATION AF SYSTEMET SKAL MAN NØJE OVERHOLDE DE GÆLDENDE REGLER FOR DISSE ANLÆG.

N.B.: VED INSTALLASJON AV SYSTEMET SKAL ALLE FORSKRIFTER OM INSTALLASJON SOM GJELDER FØLGES STRENGT.

OBS! UNDER INSTALLATIONEN AV SYSTEMET SKA INSTALLATIONSFÖRESKRIFTERNA RESPEKTERAS I DETALJ.

ПРИМЕЧАНИЕ: В ПРОЦЕССЕ МОНТАЖА СИСТЕМЫ СТРОГО СОБЛЮДАЙТЕ НАЦИОНАЛЬНЫЕ ДЕЙСТВУЮЩИЕ НОРМАТИВЫ ПО ЭЛЕКТРОПРОВОДКЕ.

注意：在安装系统时请遵守设备的安装规定。

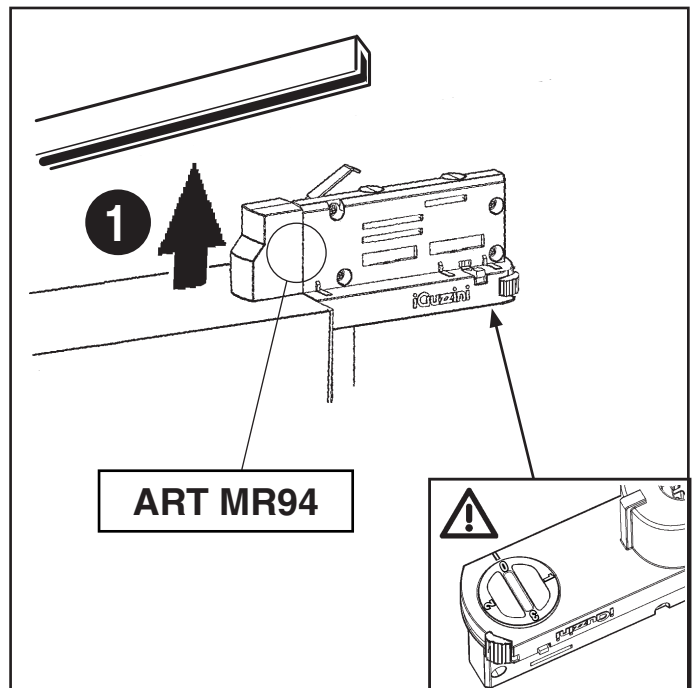

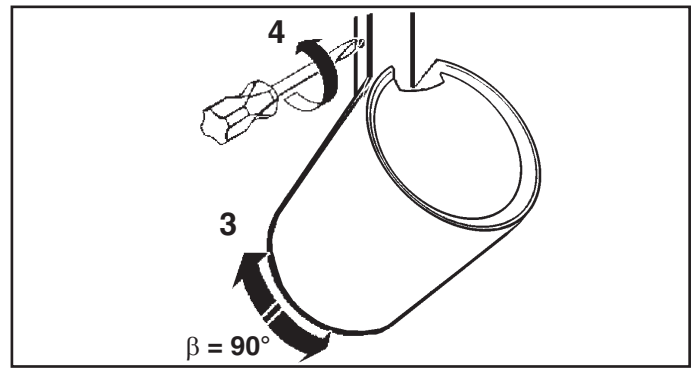
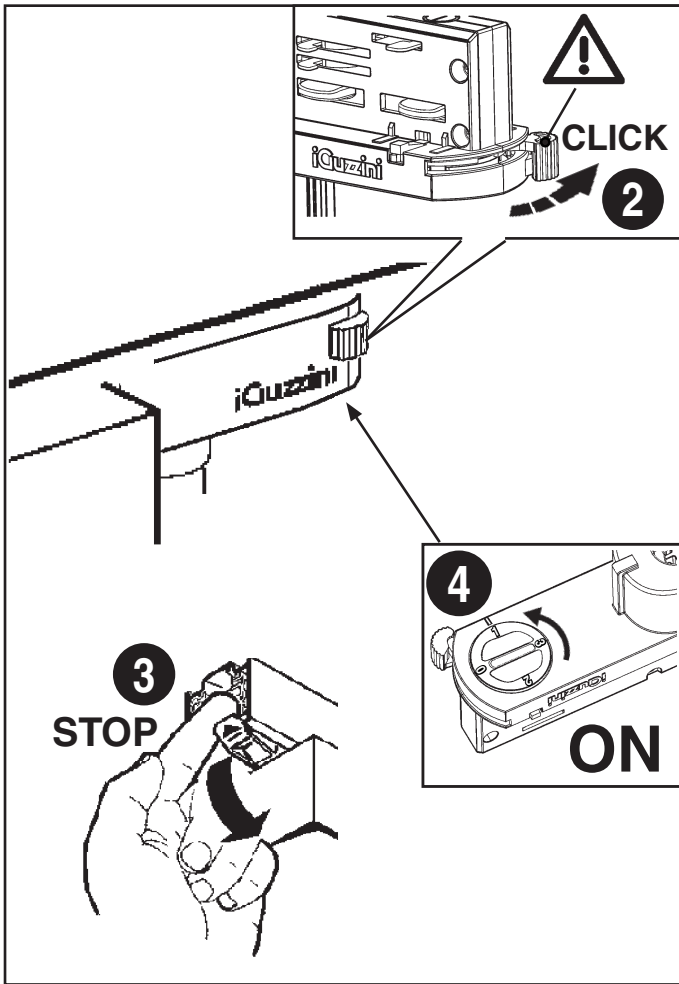

+ ART				
ART.				
S	MY45	MY51	MY52	MY85
M	1191	MY46	MY88	MY89
L	MXV6	MXW3	-	-

BLOCCO MECCANICO DEL PUNTAMENTO DEL VANO  
 MECHANICAL LOCKING OF THE ASSEMBLY AIMING SYSTEM  
 VERROUILLAGE MÉCANIQUE DE L'ORIENTATION DU BLOC OPTIQUE  
 MECHANISCHE BLOCKIERVORRICHTUNG DES LEUCHTENGEHÄUSES  
 MECHANISCHE BLOKKERING VAN DE RICHTING VAN DE BEHUIZING  
 BLOQUEO MECÁNICO DEL PUNTO DE ENFOQUE DEL CUERPO  
 MEKANISK LÅS TIL OPSÆTNING AF DEN OPTISKE ENHEDS RETNING  
 MEKANISK LÅSING AV DET OPTISKE ROMMETS RETNING  
 MEKANISK BLOKKERING AV DET OPTISKA RUMMETS RIKTNING  
 МЕХАНИЧЕСКАЯ БЛОКИРОВКА ОРИЕНТАЦИИ ОТСЕКА  
 装配瞄准系统的机械闭锁

	S	M
+  /  +  +	NO	NO
+  /  +	OK	OK
+  /  +	OK	OK
+  +	NO	NO

- I Se necessario, é possibile bloccare l'orientamento del vano ottico tramite le operazioni 2 e 4.
- GB If necessary, it is possible to fix the optical assembly by steps 2, 4.
- F Si nécessaire, il est possible de bloquer l'orientation du groupe optique en effectuant les opérations 2 et 4.
- D Falls nötig, kann das Optikgehäuse mittels der Operationen 2, und 4 blockiert werden.
- NL Indien noodzakelijk kunt u de richting van het verlichtingsarmatuur vastzetten door de handelingen 2 en 4 uit te voeren.
- E De ser necesario es posible detener la orientación de la óptica, efectuando las operaciones 2 y 4.
- DK Hvis det er nødvendigt, kan man fastlåse retningen på den optiske enhed ved at følge fremgangsmåden i 2 og 4.
- N Ved behov, er det mulig å feste den optiske enheten ved trinn 2, 4.
- S Om det är nödvändigt går det att blockera det optiska rummets riktning med momenten 2 och 4.
- RUS При необходимости можно заблокировать направление оптического проема с помощью операций 2 и 4.
- CN 需要时, 可以按照1、4号操作来固定光学组装置位置。

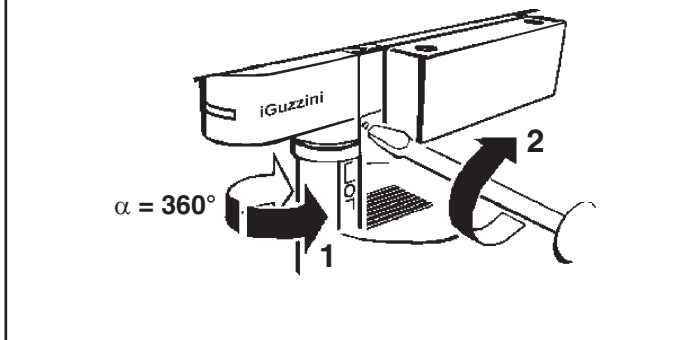
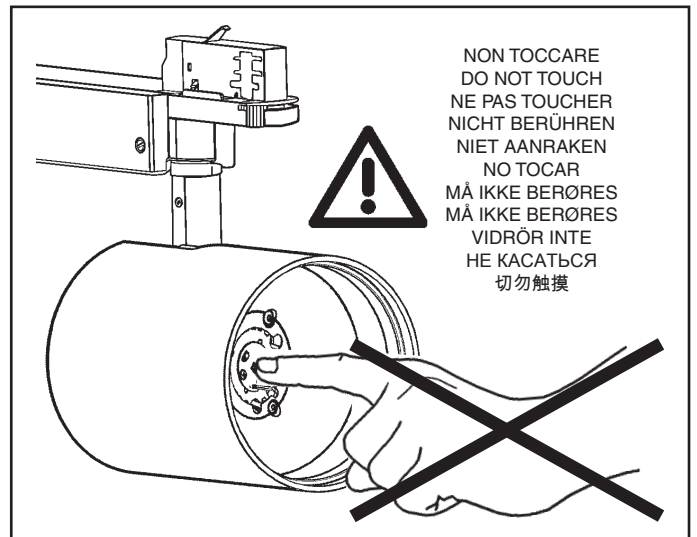

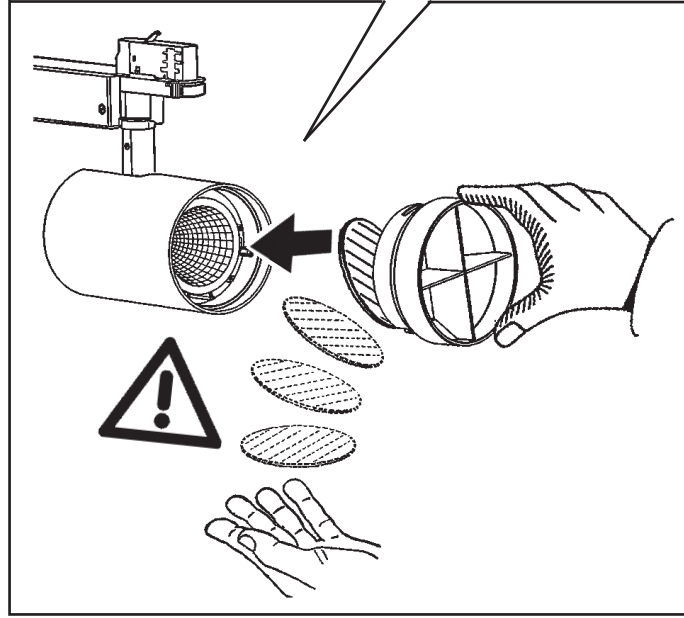
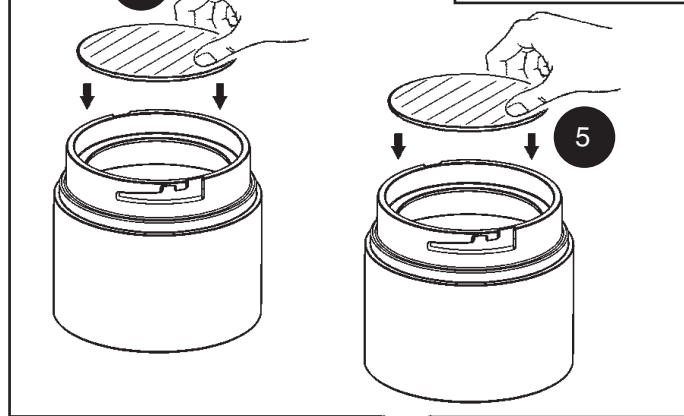
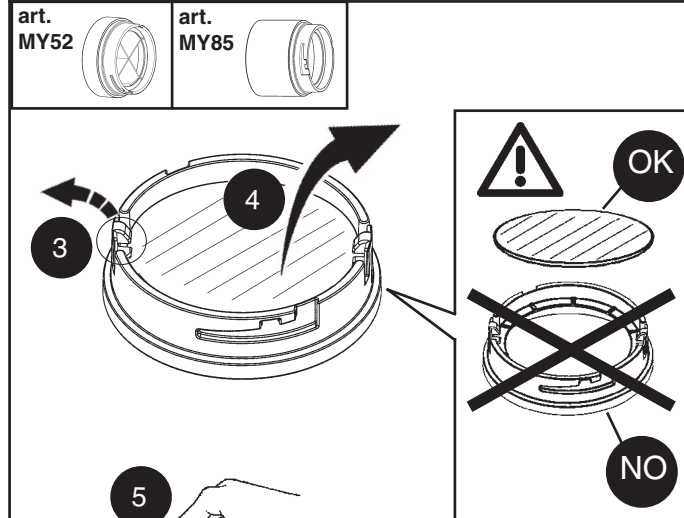
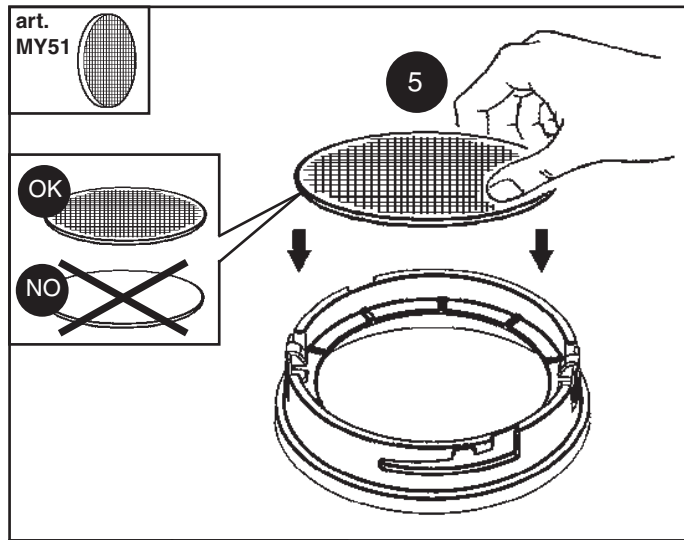
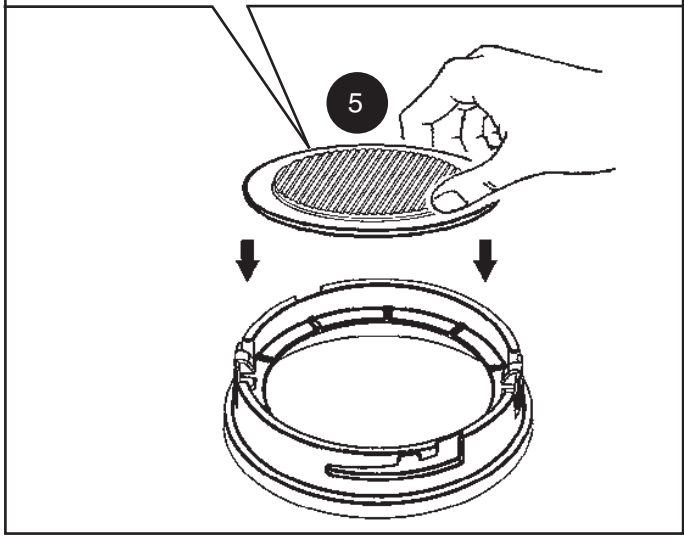
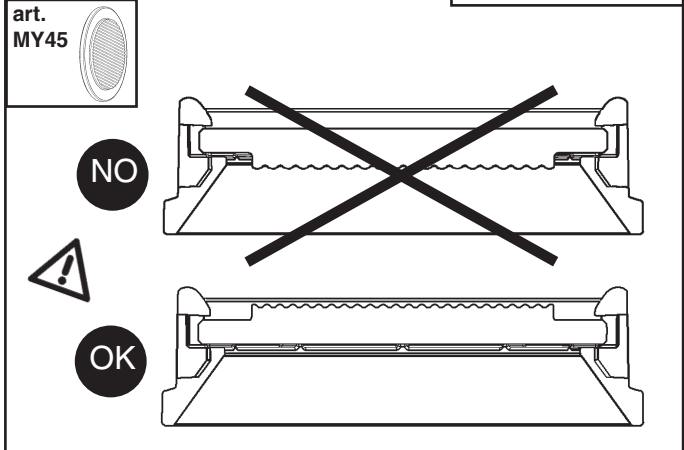
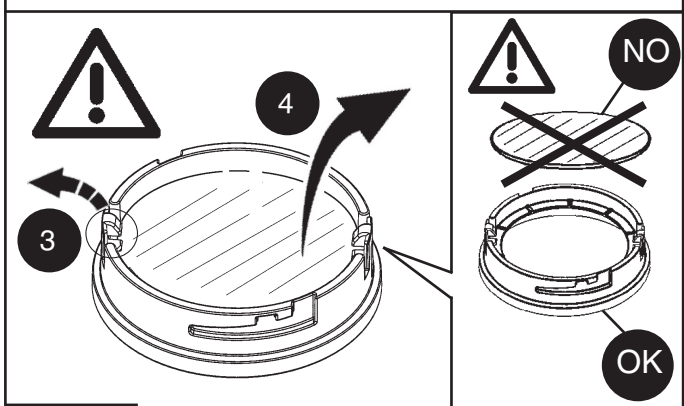
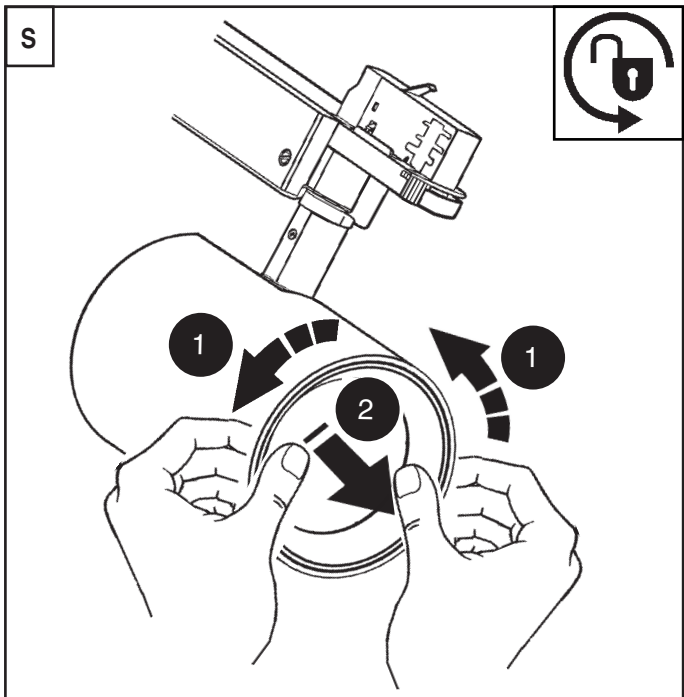

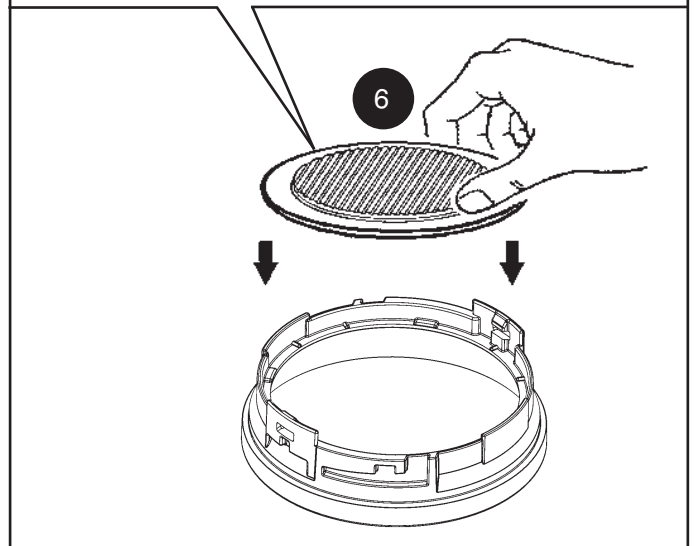
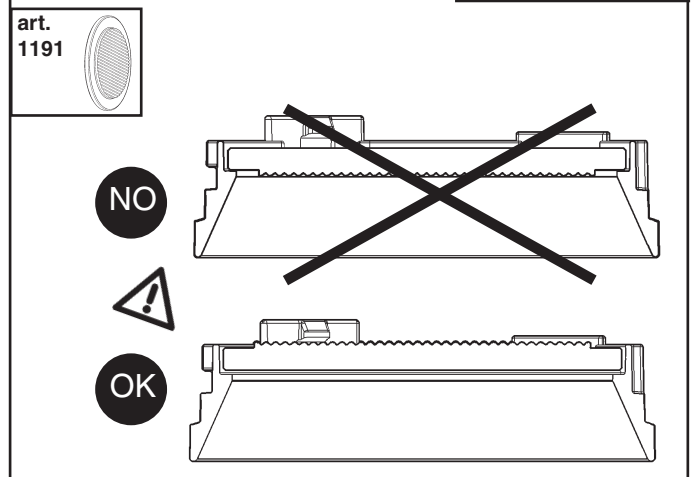
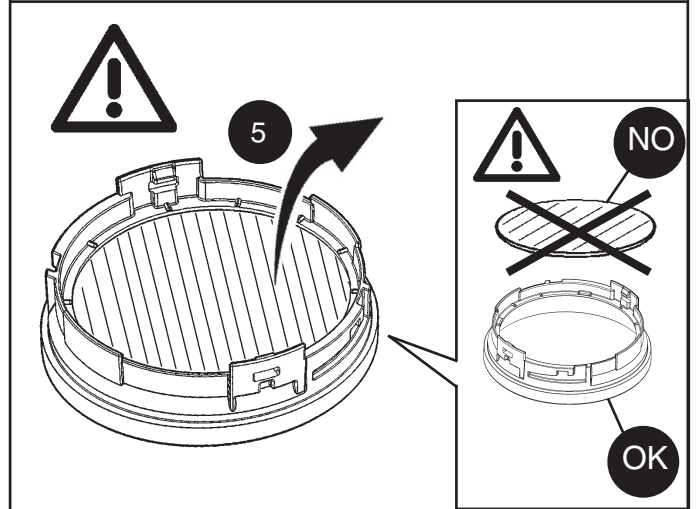
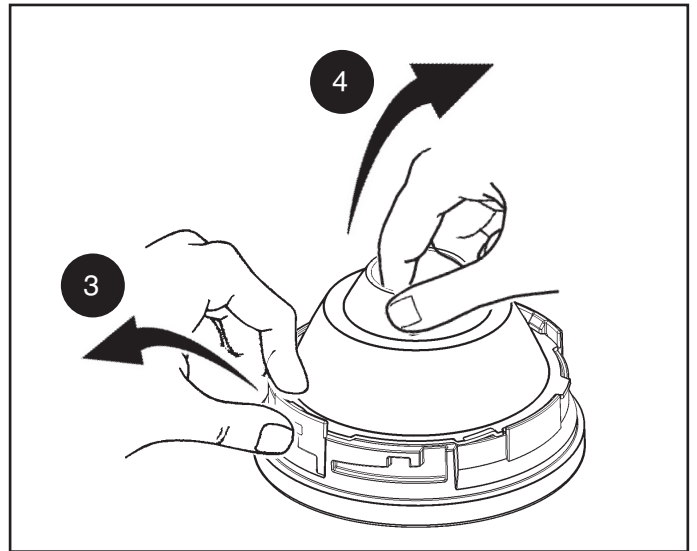
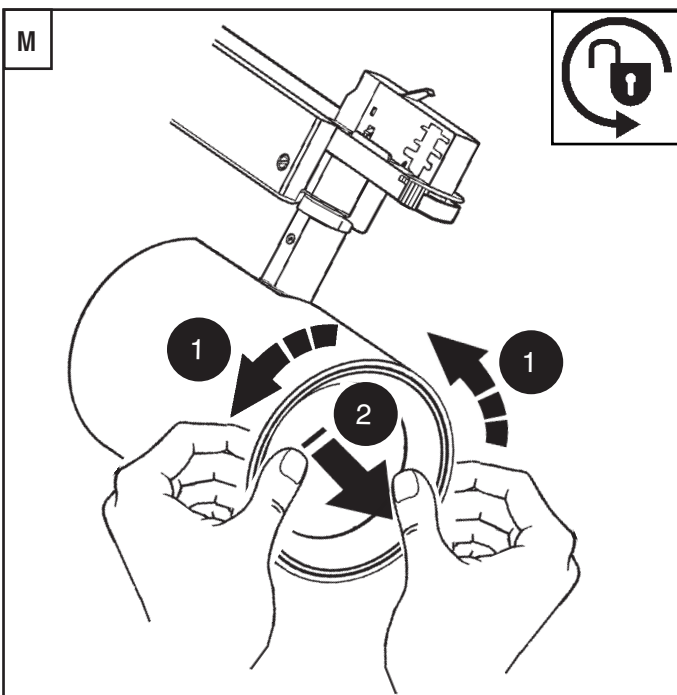
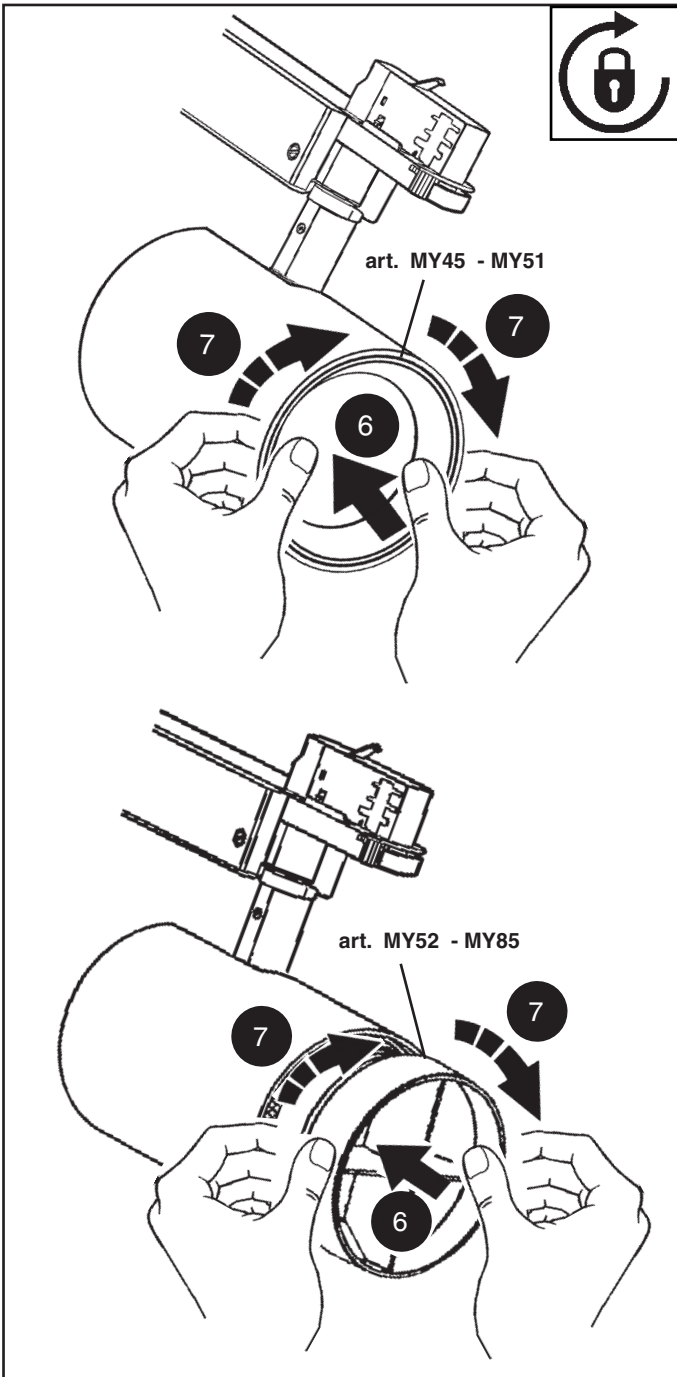



art.  
MY46

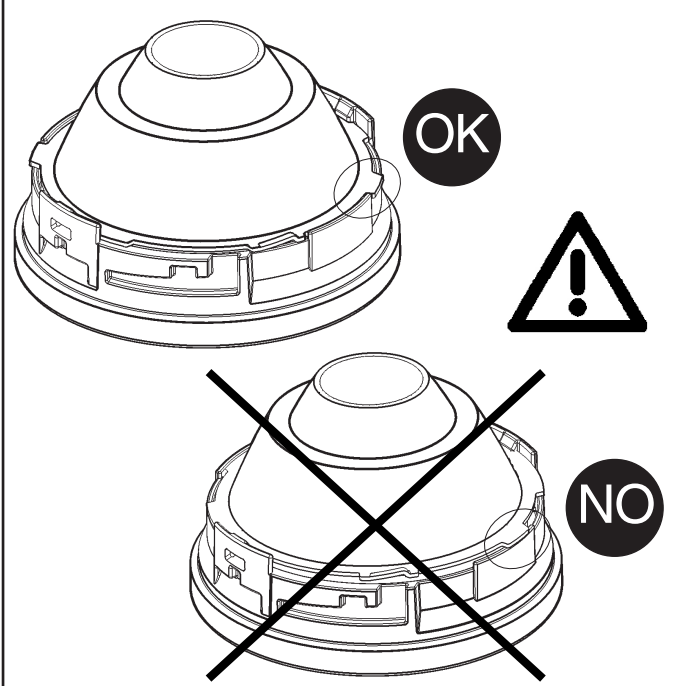
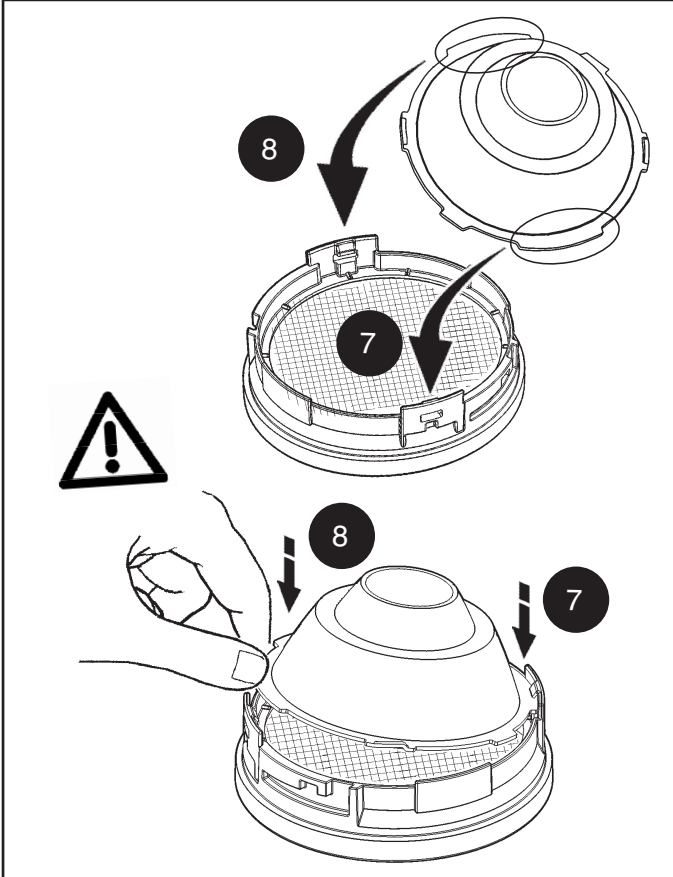
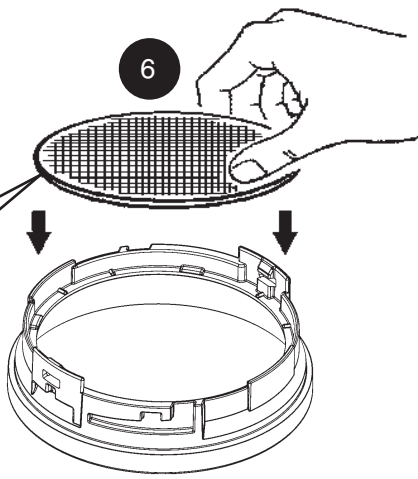
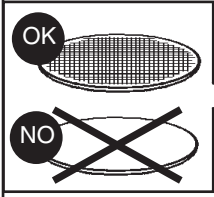
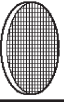

art.  
MY88



art.  
MY89

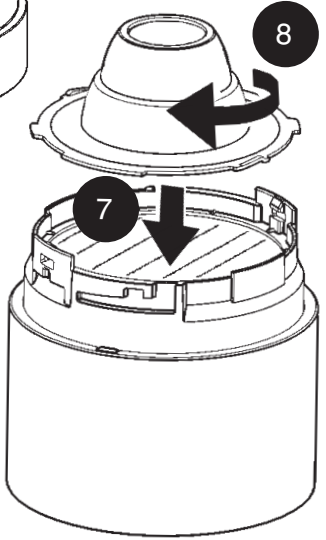
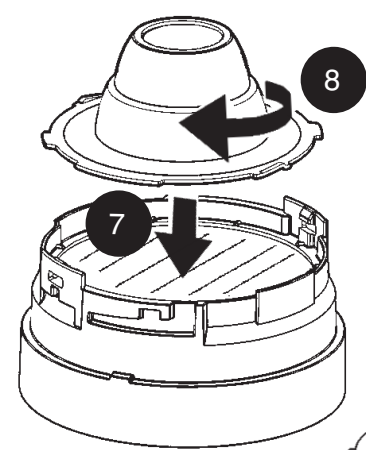
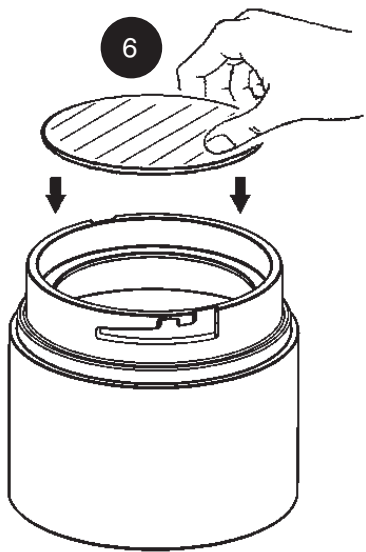
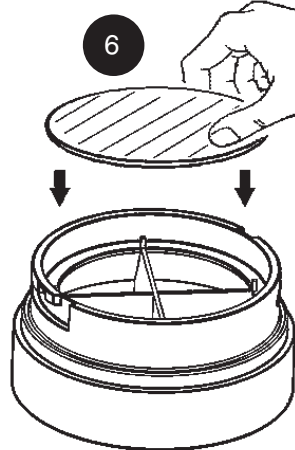
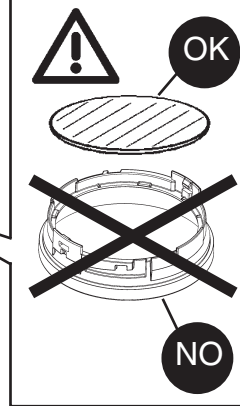
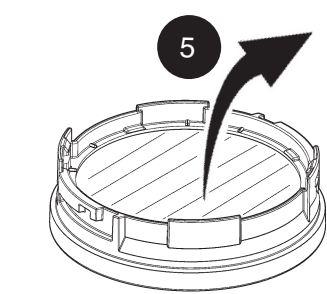
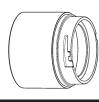

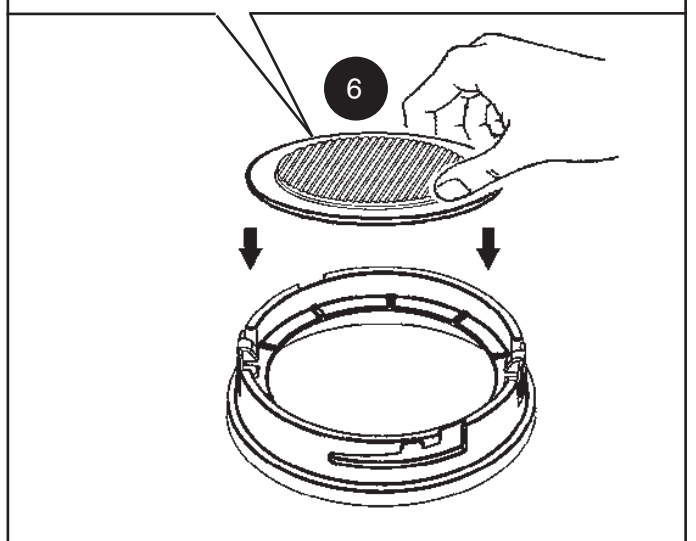
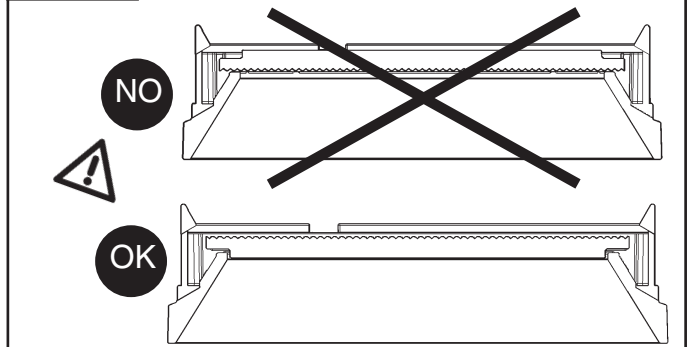
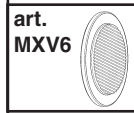
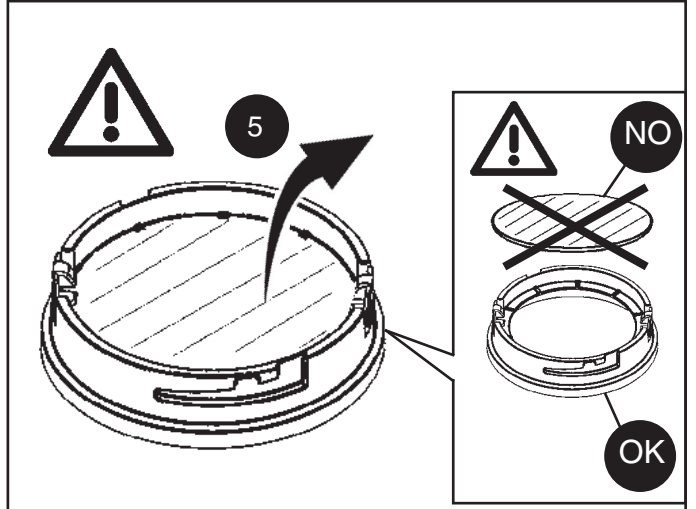
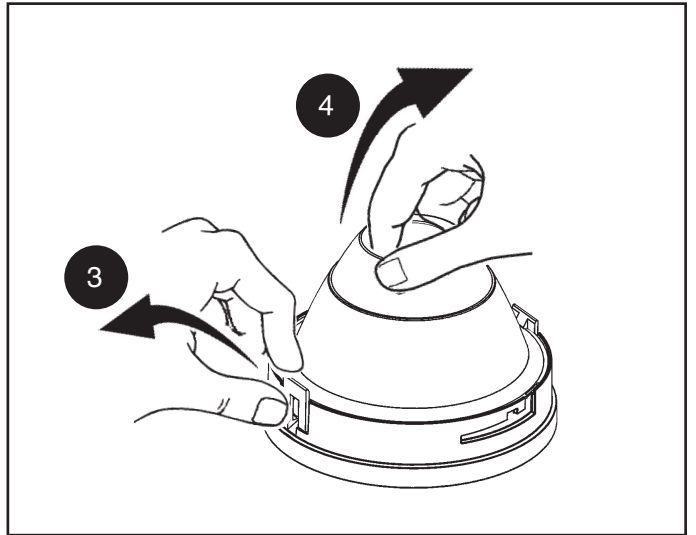
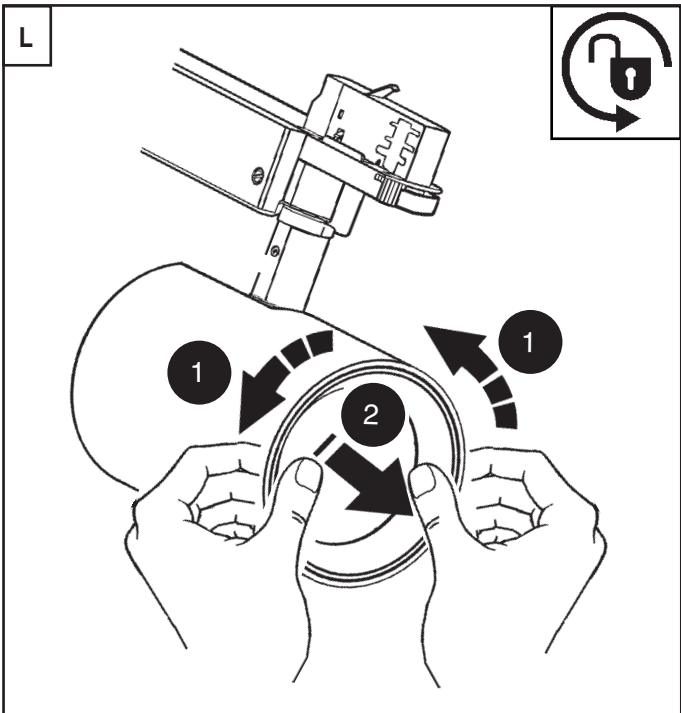
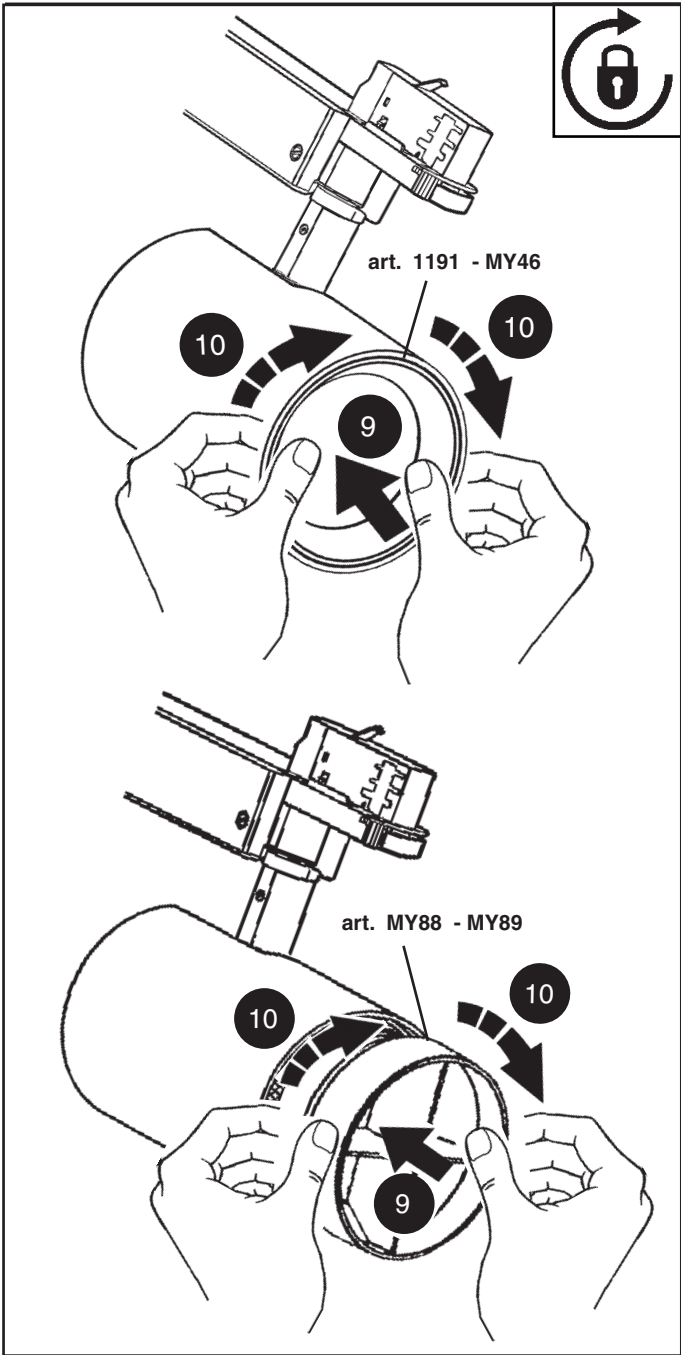

art.  
MXW3

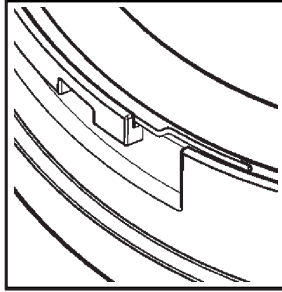
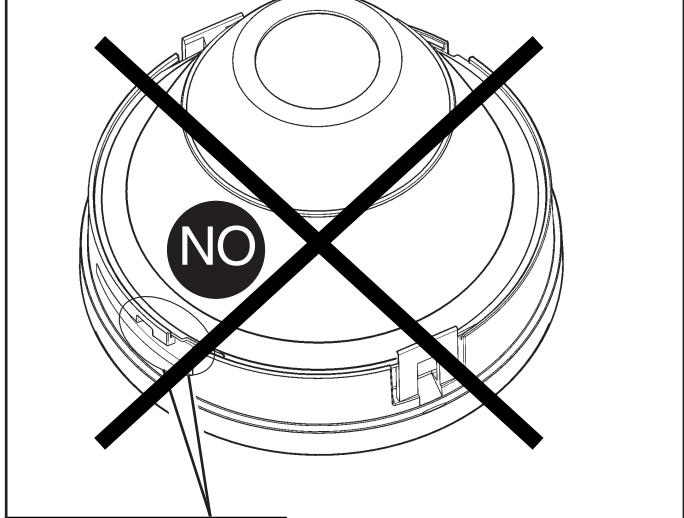
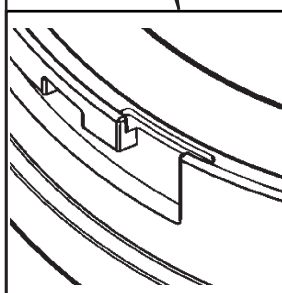
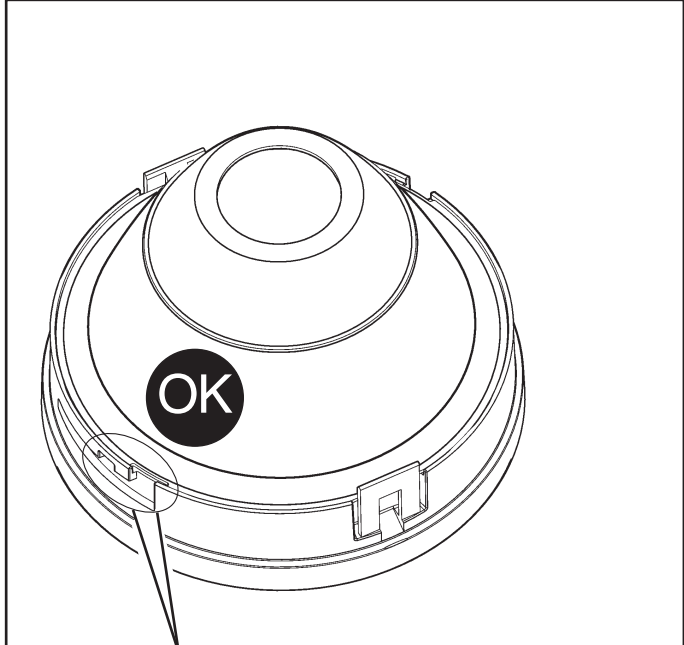
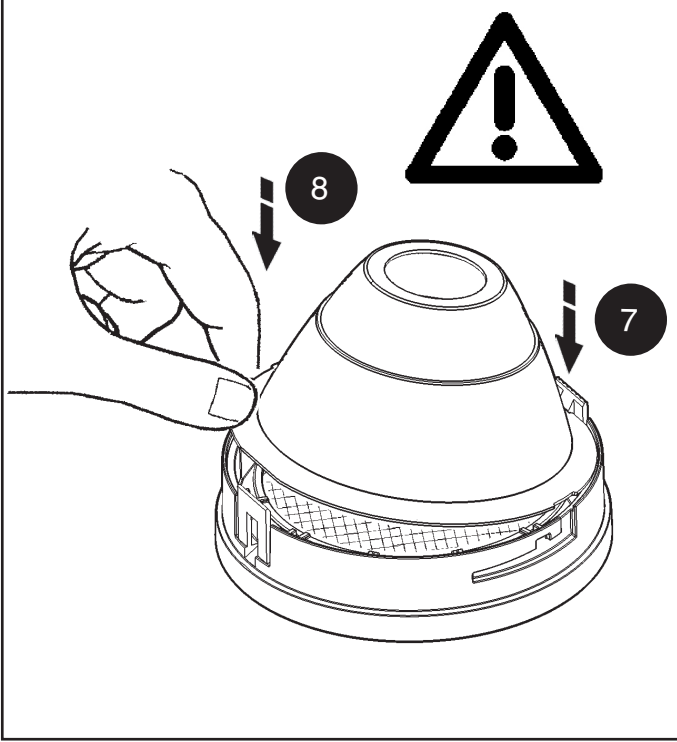
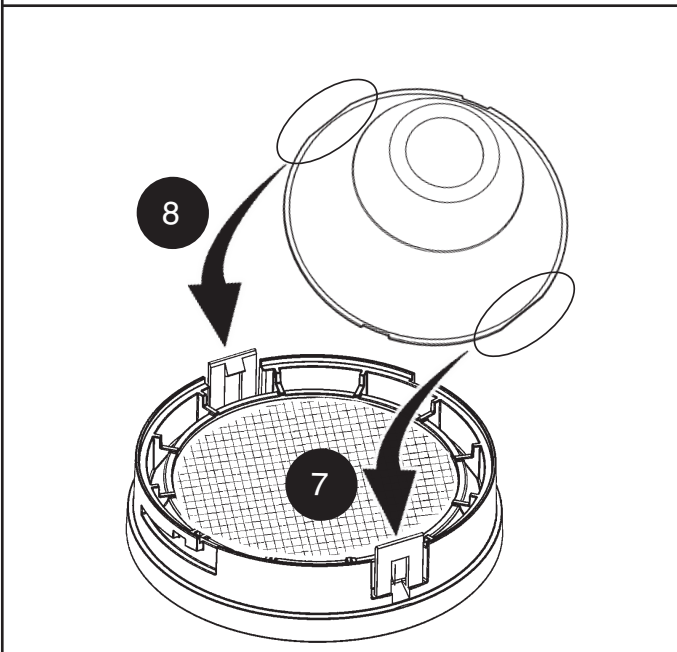
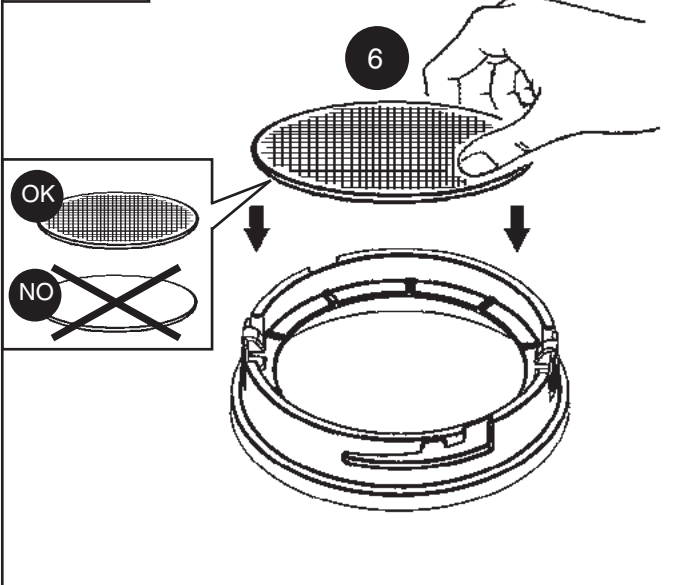
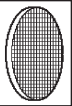

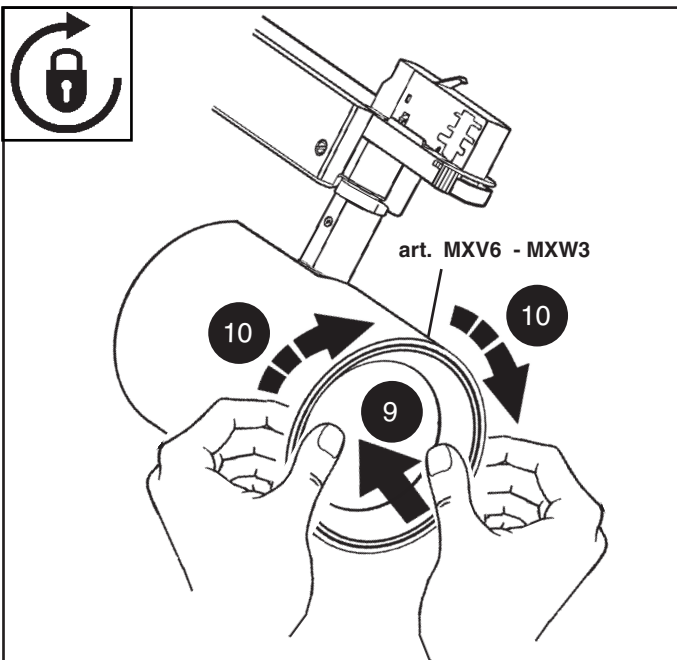

**SOSTITUZIONE DEL LED**  
**REPLACING THE LED**  
**REEMPLACEMENT DE LA LED**  
**AUSTAUSCHEN DER LED**  
**VERVANGEN VAN DE LED**  
**REEMPLAZO DEL LED**  
**UDSKIFTNING AF LYSDIODE**  
**BYTE AV LYSDIOD**  
**UTSKIFTNING AV DEN LYSEMITTERENDE DIODEN**  
**Замена светодиода**  
**发光二极管替换**

**I N.B.:** Per la sostituzione del LED contattare l'azienda iGuzzini.  
**GB N.B.:** For information on LED replacement please contact iGuzzini.  
**F N.B.:** Pour procéder au remplacement de la LED, adressez-vous à la société iGuzzini.  
**D N.B.:** Bezüglich des Austausches der LED kontaktieren Sie bitte die Firma iGuzzini.  
**NL N.B.:** Voor het vervangen van de LED neemt u contact op met het bedrijf iGuzzini.  
**E NOTA:** Para sustituir el LED llame a la empresa iGuzzini.  
**DK N.B.:** For udsifting av den lysemitterende dioden ta kontakt med firmaet iGuzzini.  
**N N.B.:** For udsiftingning af lysdioden, skal man kontakte iGuzzini.  
**S OBS!** För byte av lysdioden, kontakta företaget iGuzzini.  
**RUS ПРИМЕЧАНИЕ:** Для замены СИДов обращайтесь в компанию iGuzzini.  
**CN 注意:** 如需LED更换的信息, 请联系iGuzzini。



**VETRO SODICO-CALCICO TEMPRATO**  
**TEMPERED SODA-LIME GLASS**  
**VERRE SODIQUE-CALCIQUE TEMPRÉ**  
**NATRIUM-KALZIUM-GLAS**  
**GETEMPERD NATRIUMKALKGLAS**  
**CRISTAL SÓDICO-CALCÁREO TEMPLADO**  
**HÆRDET NATRONKALKGLAS**  
**TEMPERERT KALK-NATRON-GLASS**  
**HÄRDAT KALK-SODAGLAS**  
**ЗАКАЛЕННОЕ НАТРИЕВО-КАЛЬЦИЕВОЕ СТЕКЛО**  
**钢化钙钠玻璃**

**I** In caso di rottura del vetro il prodotto non può essere utilizzato, contattare il costruttore per la sua sostituzione.  
**GB** Should the glass break, the product cannot be used. Contact the manufacturer about its replacement.  
**F** En cas de cassure du verre, ne pas utiliser le produit et contacter aussitôt le fabricant pour son remplacement.  
**D** Im Falle einer Beschädigung des Glases darf das Produkt nicht verwendet werden. Setzen Sie sich bitte mit dem Hersteller in Verbindung, der für den Ersatz sorgen wird.  
**NL** In geval het glas gebroken is kan het product niet worden gebruikt. Neem contact op met de fabrikant voor de vervanging van het glas.  
**E** En caso de ruptura del cristal no utilizar el producto y contactar el fabricante para la sustitución.  
**DK** Hvis produktets glas ødelægges, kan det ikke anvendes. Kontakt forhandleren med henblik på udsiftingning.  
**N** I tilfelle glasset går i stykker kan produktet ikke tas i bruk, kontakt produsenten for udsiftingning av det.  
**S** Om glaset går sönder kan inte produkten användas. Kontakta tillverkaren för att byta ut glaset.  
**RUS** В случае разбивания стекла не используйте прибор, обратитесь к его производителю для замены.  
**CN** 且玻璃破碎后产品将不能再使用, 须联系生产商予以更换。



## TECNICA PRO

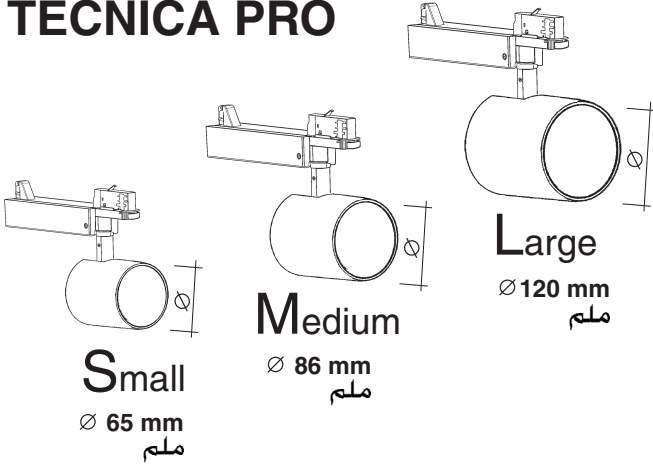

تحذير:

لا يمكن ضمان سلامة هذا الجهاز إلا إذا التزمت بهذه التعليمات. يجب حفظها في مكان آمن.

### ATTENZIONE:

LA SICUREZZA DELL'APPARECCHIO E' GARANTITA SOLO CON L'USO APPROPRIATO DELLE SEGUENTI ISTRUZIONI; PERTANTO E' NECESSARIO CONSERVARLE.

### WARNING:

THE SAFETY OF THIS FIXTURE IS GUARANTEED ONLY IF YOU COMPLY WITH THESE INSTRUCTIONS; REMEMBER TO CONSERVE IN A SAFE PLACE.

### ATENCION:

LA SEGURIDAD DEL APARATO SE GARANTIZA SOLO CUMPLIENDO CUIDADOSAMENTE LAS SIGUIENTES INSTRUCCIONES; POR ELLO, ES NECESARIO CONSERVARLAS.

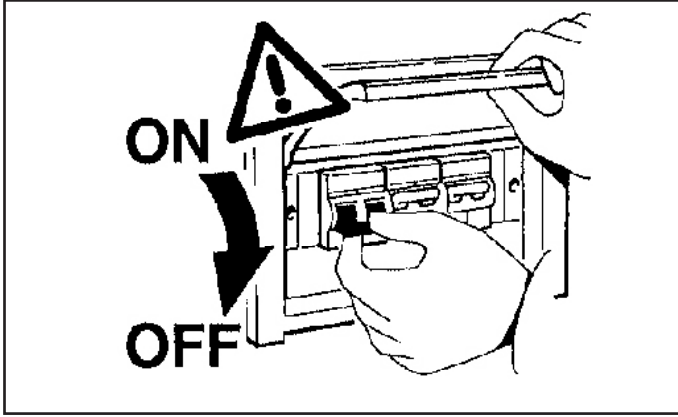

ضمن عمل المنتجات فقط من خلال استعمال سكة ومعدات من نوع iGuzzini

I Il funzionamento dei prodotti è garantito solo con l'utilizzo di binari ed accessori iGuzzini

GB Correct product operation is only guaranteed if iGuzzini tracks and accessories are used.

E El funcionamiento de los productos se garantiza solamente si se utilizan railes y accesorios iGuzzini.

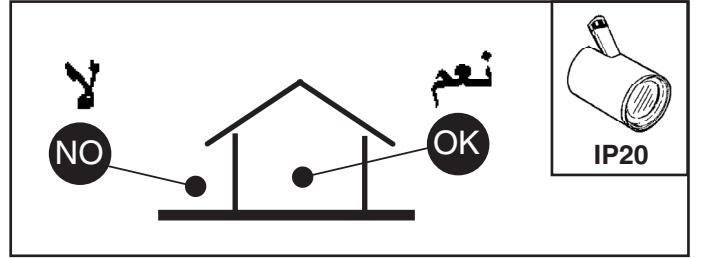
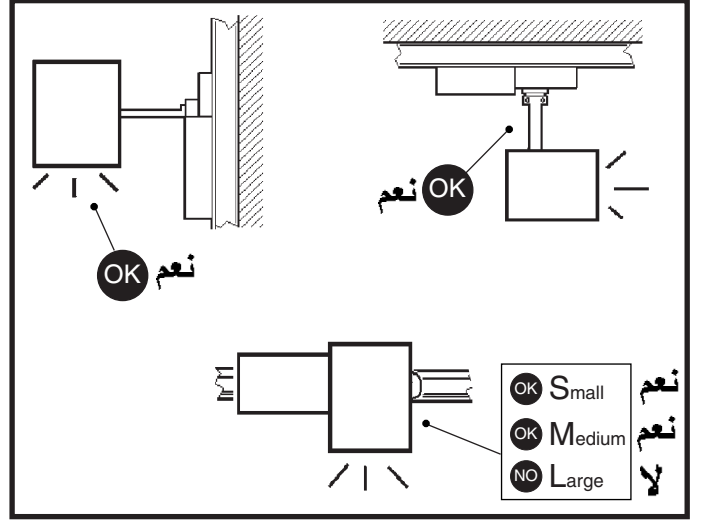

N.B.: DURANTE L'INSTALLAZIONE DEL SISTEMA RISPETTARE SCRUPolosAMENTE LE NORME IMPIANTISTICHE VIGENTI.

N.B.: WHEN INSTALLING THE SYSTEM, STRICTLY COMPLY WITH ALL REGULATIONS ON INSTALLATION IN FORCE.

N.B.: LORS DE L'INSTALLATION DU SYSTÈME VEUILLEZ RESPECTER RIGOREUSEMENT LES NORMES EN VIGUEUR EN LA MATIÈRE.

NB: BEACHTEN SIE BEI DER INSTALLATION DES SYSTEMS GEWISSENHAFT DIE GÜLTIGEN BESTIMMUNGEN BEZÜGLICH DER ANLAGENTECHNIK.

N.B.: BIJ HET INSTALLEREN VAN HET SYSTEEM MOET U DE GELDEN DE INSTALLATIE-NORMEN STRIKT NALEVEN.

N.B.: DURANTE LA INSTALACIÓN DEL SISTEMA RESPETAR E SCRUPolosAMENTE LAS NORMAS DE INSTALACIÓN VIGENTES.

N.B.: UNDER INSTALLATION AF SYSTEMET SKAL MANNØJE OVERHOLDE DE GÆLDENDE REGLER FOR DISSE ANLÆG.

N.B.: VED INSTALLASJON AV SYSTEMET SKAL ALLE FORSKRIFTER OM INSTALLASJON SOM GJELDER FØLGES STRENGT.

OBS! UNDER INSTALLATIONEN AV SYSTEMET SKA INSTALLATIONSFØRESKRIFTERNA RESPEKTERAS I DETALJ.

ПРИМЕЧАНИЕ: В ПРОЦЕССЕ МОНТАЖА СИСТЕМЫ СТРОГО СОБЛЮДАЙТЕ НАЦИОНАЛЬНЫЕ ДЕЙСТВУЮЩИЕ НОРМАТИВЫ ПО ЭЛЕКТРОПРОВОДКЕ.

注意：在安装系统时请遵守设备的安装规定。

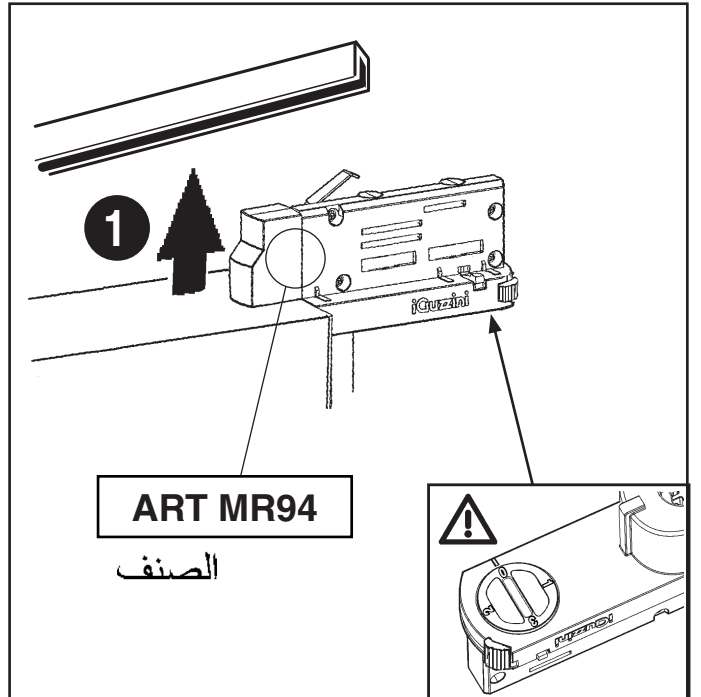

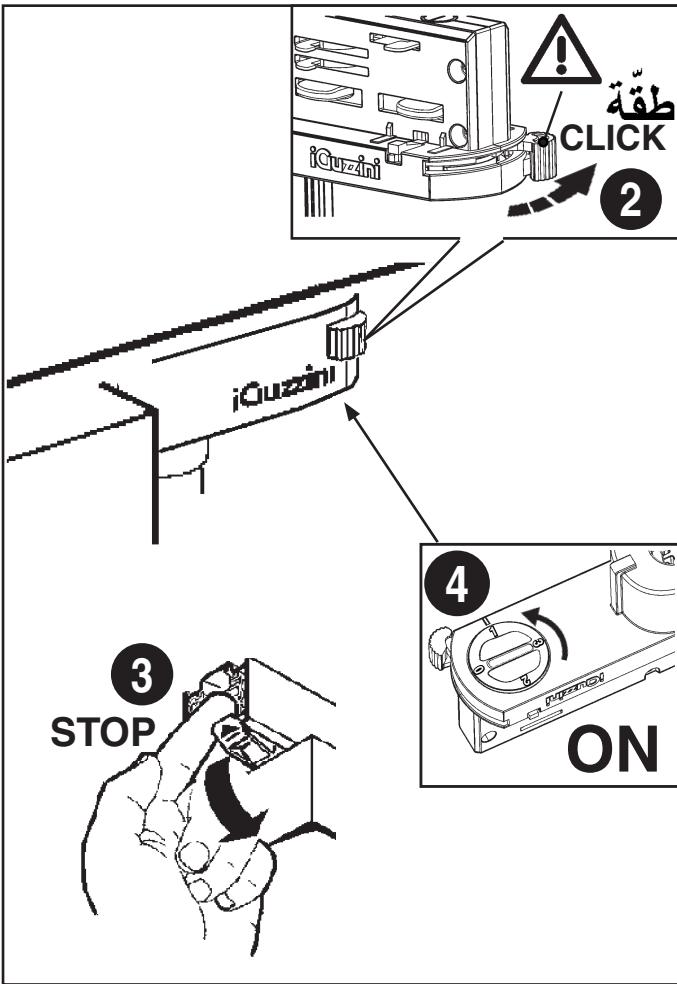

BLOCCO MECCANICO DEL PUNTAMENTO DEL VANO  
 MECHANICAL LOCKING OF THE ASSEMBLY AIMING SYSTEM  
 VERROUILLAGE MÉCANIQUE DE L'ORIENTATION DU BLOC OPTIQUE  
 MECHANISCHE BLOCKIERVORRICHTUNG DES LEUCHTENGEHÄUSES  
 MECHANISCHE BLOKKERING VAN DE RICHTING VAN DE BEHUIZING  
 BLOQUEO MECÁNICO DEL PUNTO DE ENFOQUE DEL CUERPO  
 MEKANISK LÅS TIL OPSÆTNING AF DEN OPTISKE ENHEDS RETNING  
 MEKANISK LÅSING AV DET OPTISKE RUMMETS RETNING  
 MEKANISK BLOKKERING AV DET OPTISKA RUMMETS RIKTNING  
 МЕХАНИЧЕСКАЯ БЛОКИРОВКА ОРИЕНТАЦИИ ОТСЕКА  
 装配瞄准系统的机械闭锁

- I Se necessario, é possibile bloccare l'orientamento del vano ottico tramite le operazioni 2 e 4.
- GB If necessary, it is possible to fix the optical assembly by steps 2, 4.
- F Si nécessaire, il est possible de bloquer l'orientation du groupe optique en effectuant les opérations 2 et 4.
- D Falls nötig, kann das Optikgehäuse mittels der Operationen 2, und 4 blockiert werden.
- NL Indien noodzakelijk kunt u de richting van het verlichtingsarmatuur vastzetten door de handelingen 2 en 4 uit te voeren.
- E De ser necesario es posible detener la orientación de la óptica, efectuando las operaciones 2 y 4.
- DK Hvis det er nødvendigt, kan man fastlåse retningen på den optiske enhed ved at følge fremgangsmåden i 2 og 4.
- N Ved behov, er det mulig å feste den optiske enheten ved trinn 2, 4.
- S Om det är nödvändigt går det att blockera det optiska rummets riktning med momenten 2 och 4.
- RUS При необходимости можно заблокировать направление оптического проема с помощью операций 2 и 4.
- CN 需要时, 可以按照1、4号操作来固定光学组装置位置。

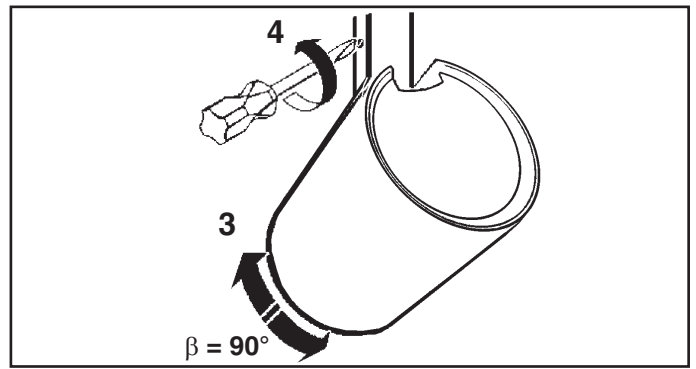
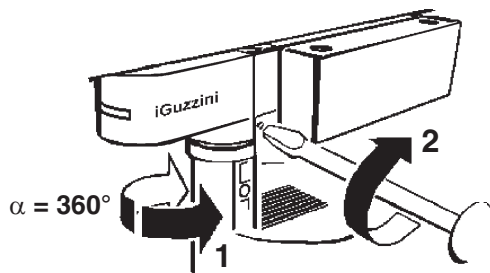

+ ART				
الصنف ART.				
S	MY45	MY51	MY52	MY85
M	1191	MY46	MY88	MY89
L	MXV6	MXW3	-	-

	S	M
+  /  +  +	NO	لا
+  /  +	OK	نعم
+  /  +	OK	نعم
+  +	NO	لا

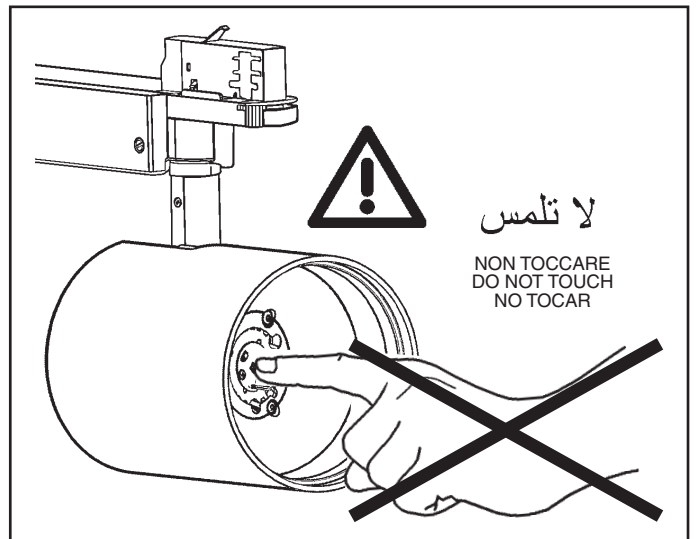

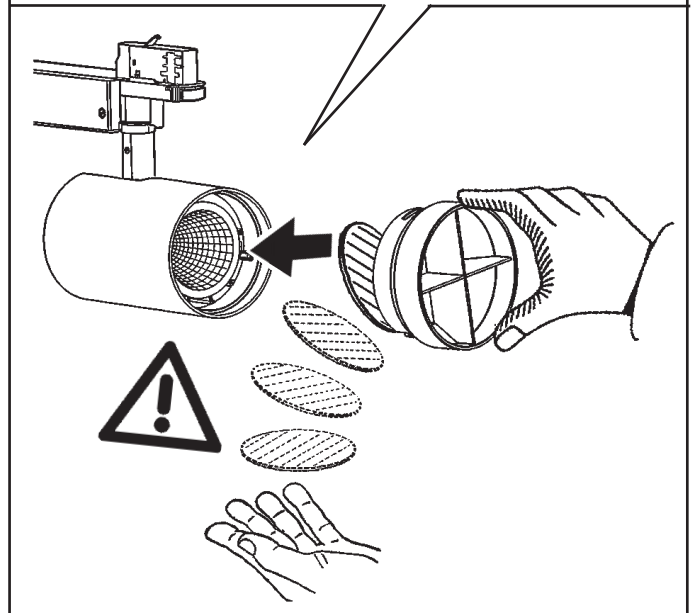
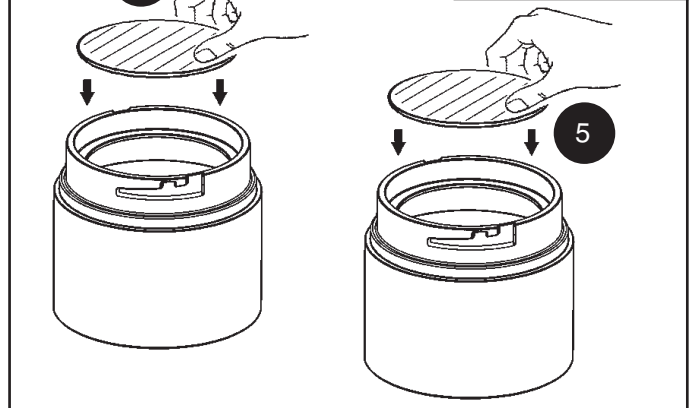
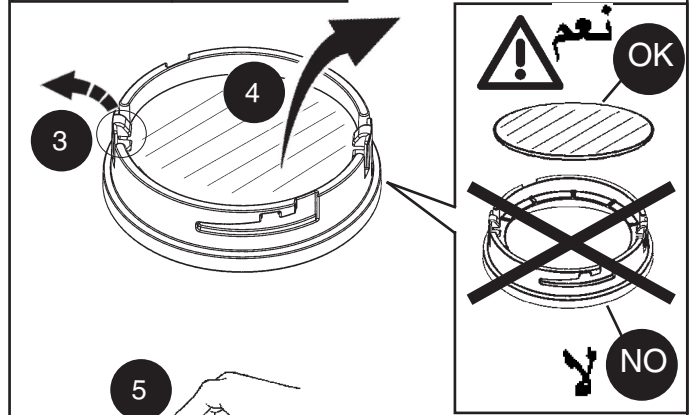
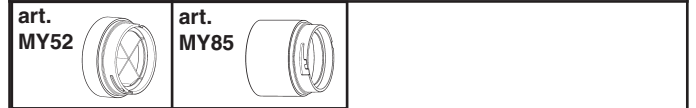
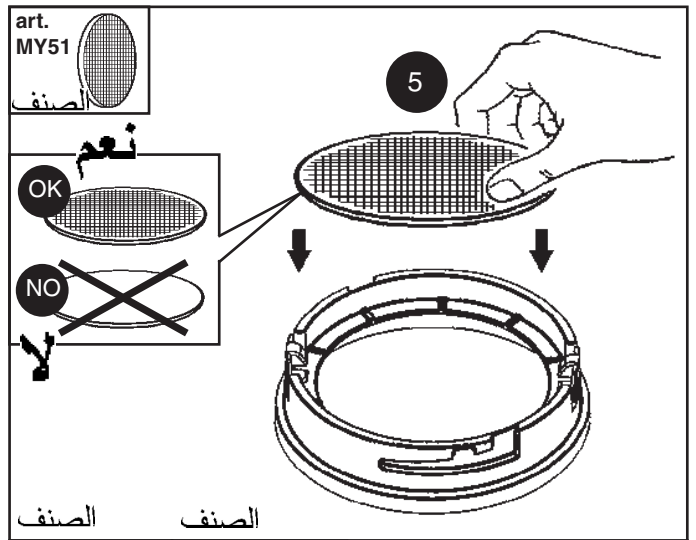
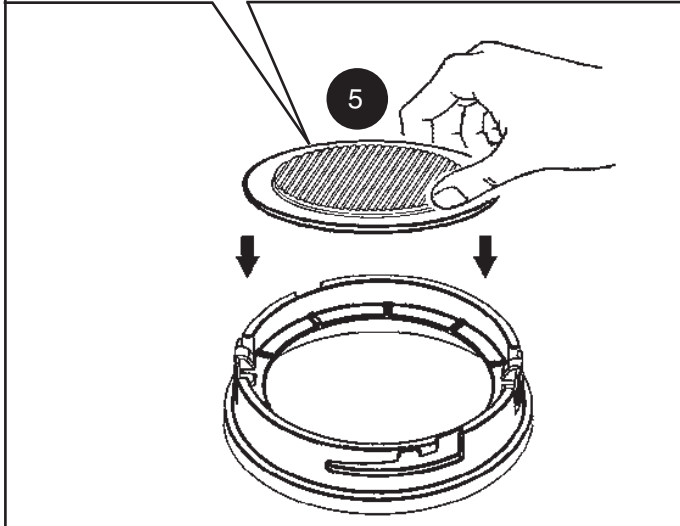
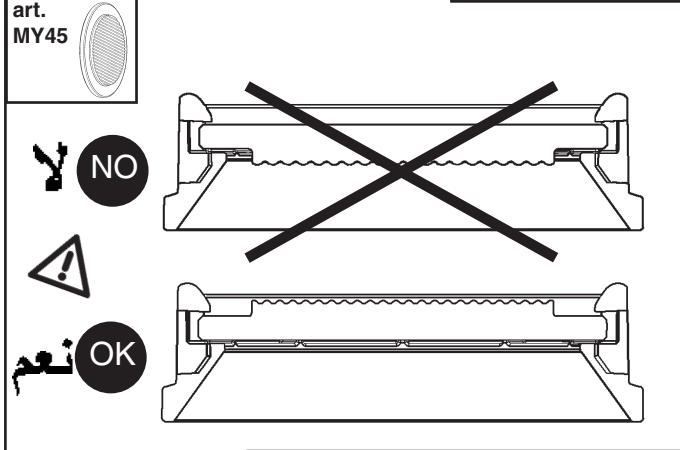
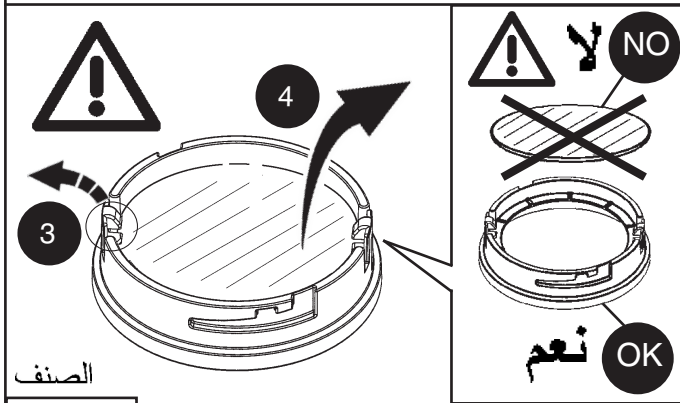
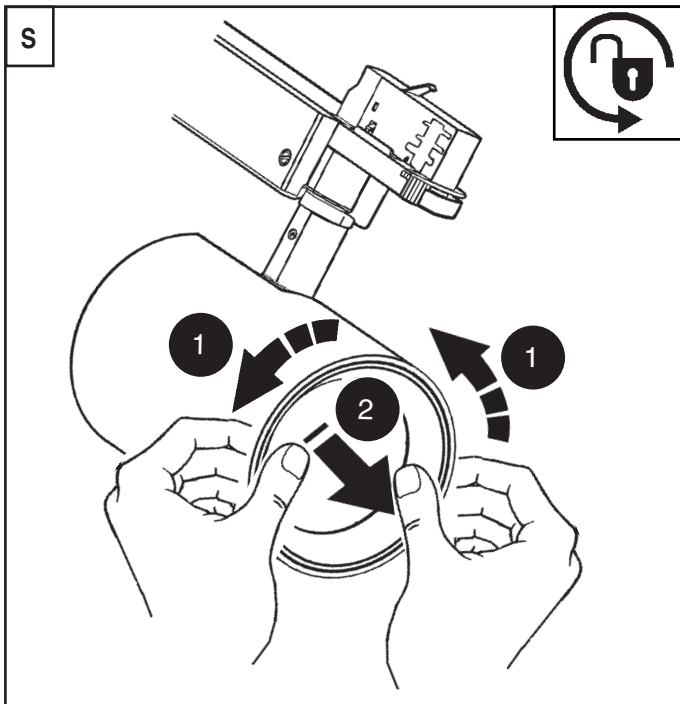

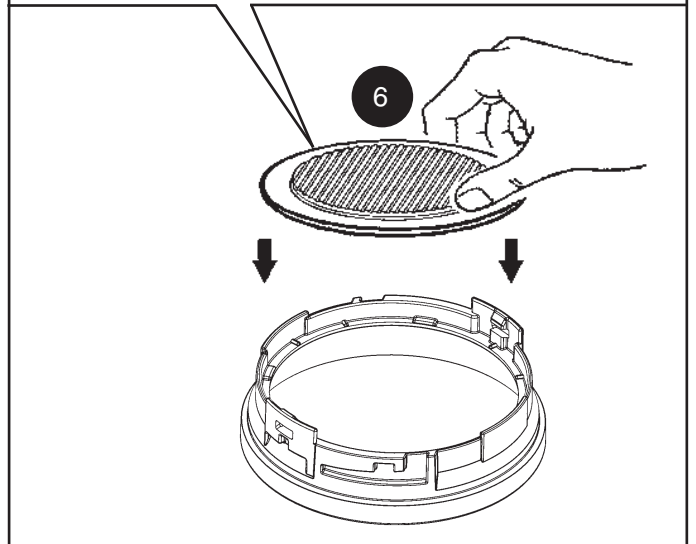
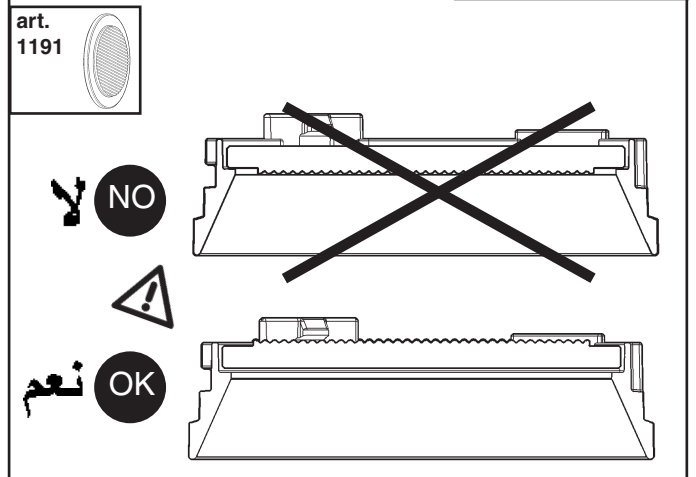
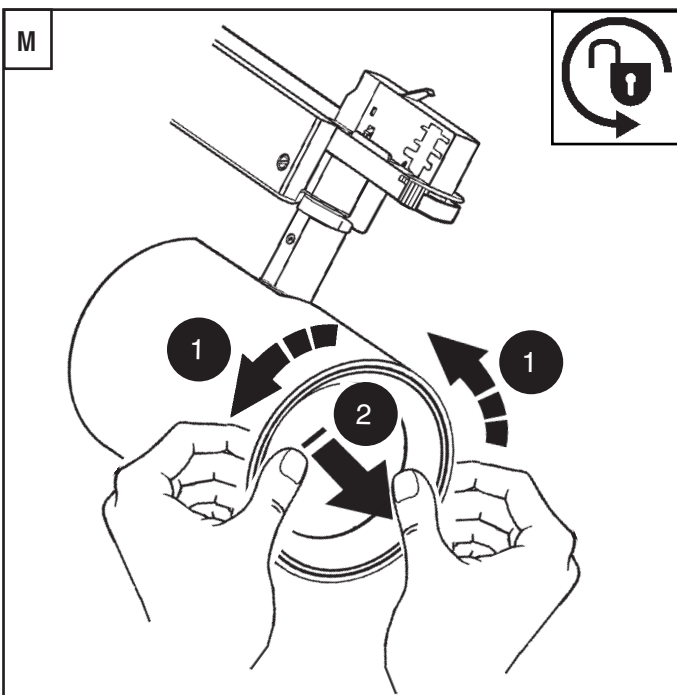
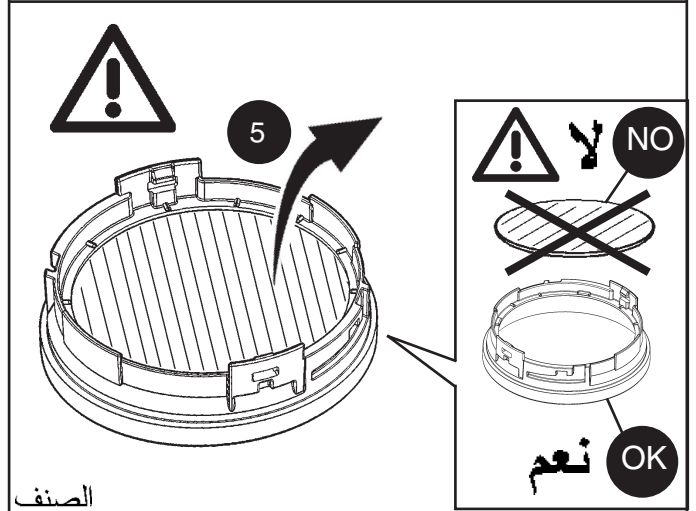
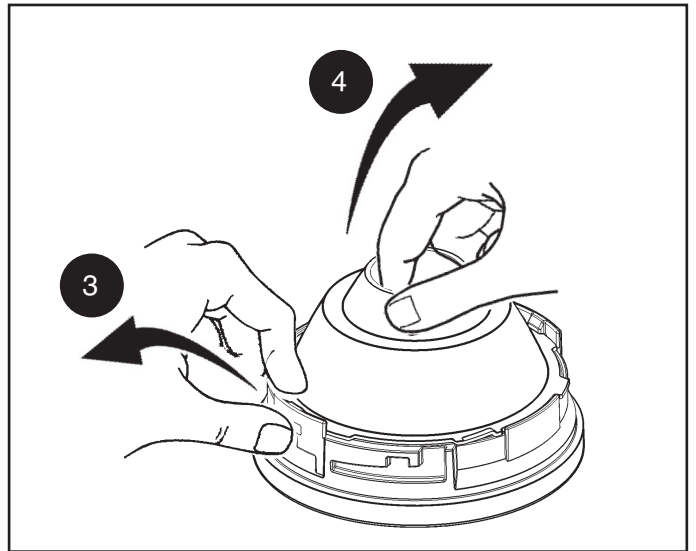
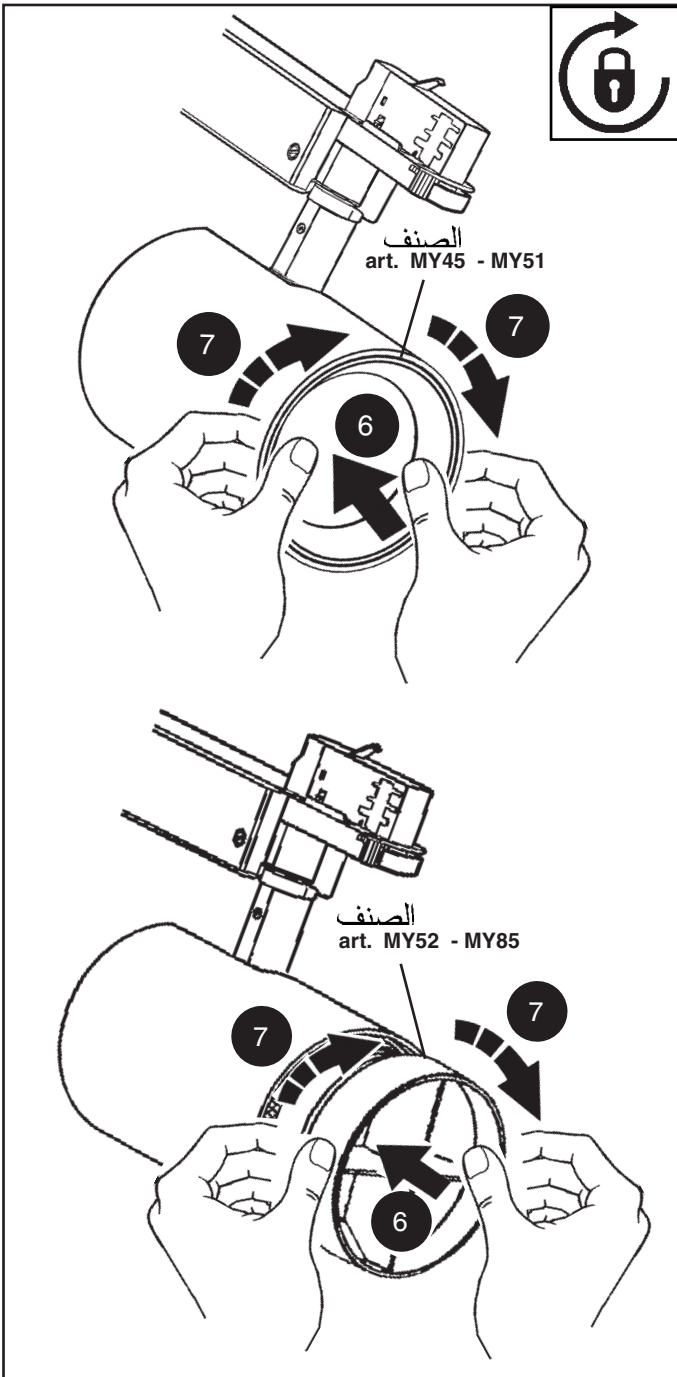

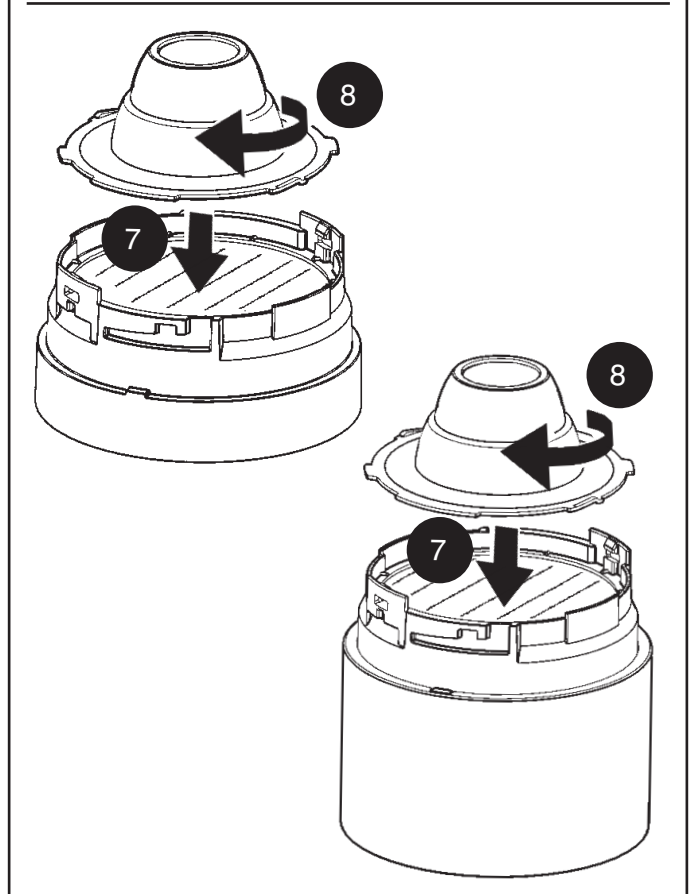
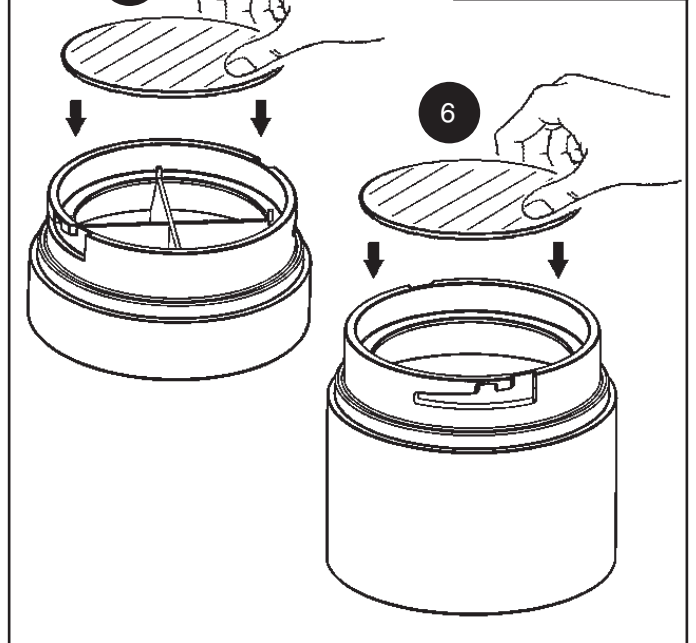
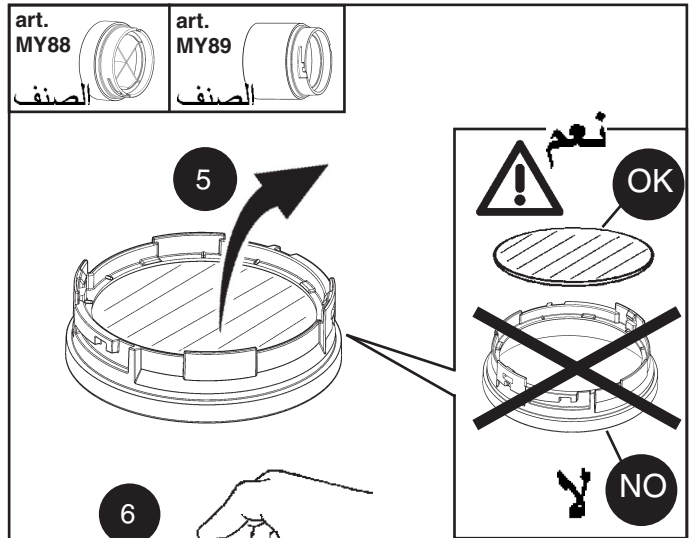
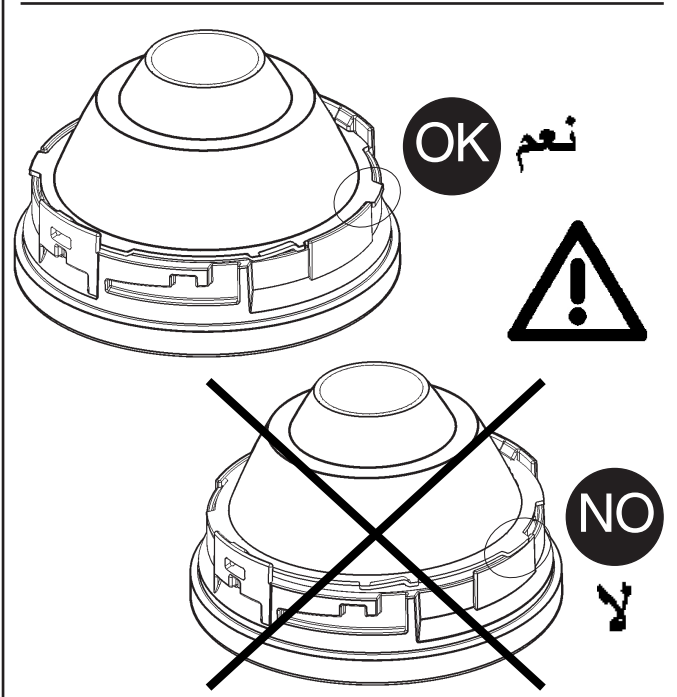
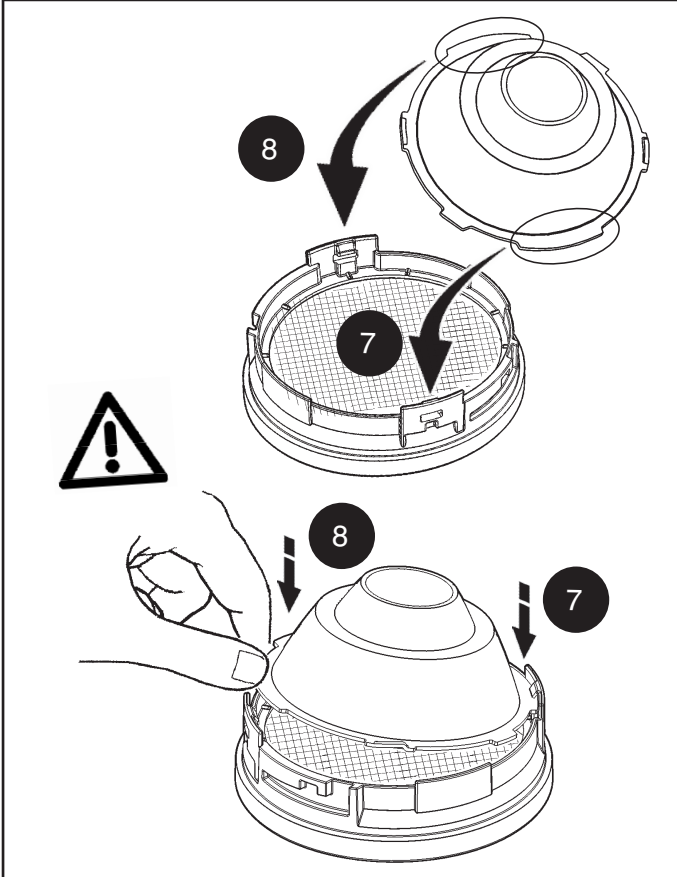
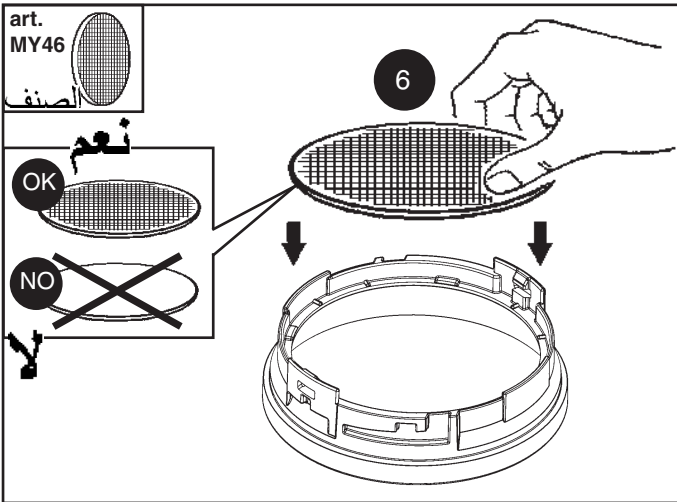



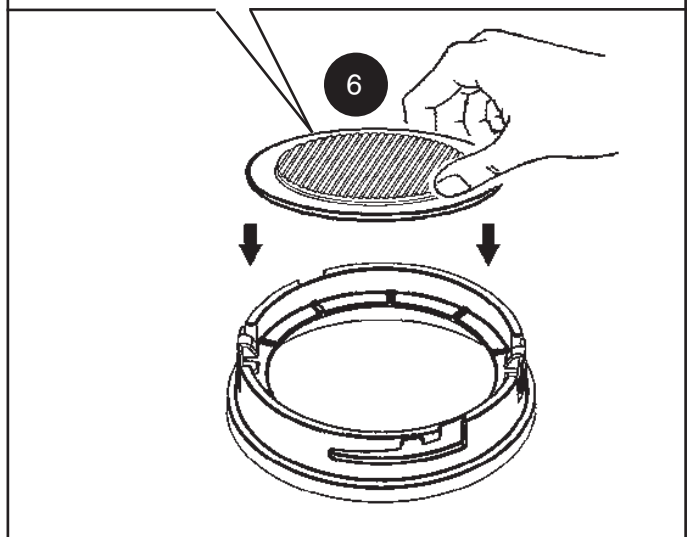
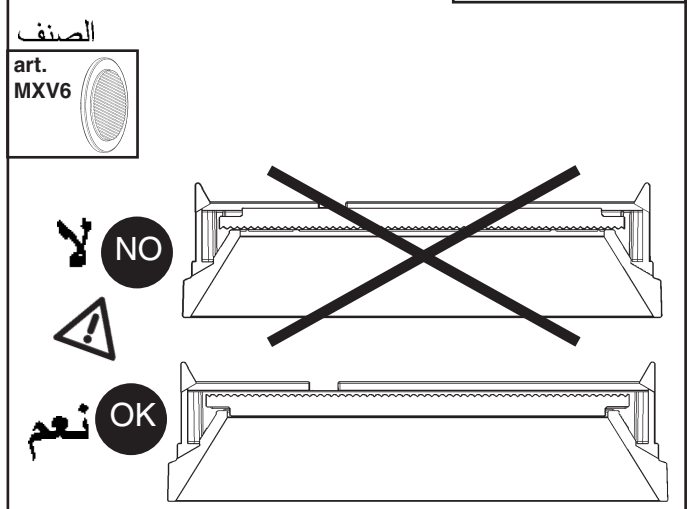
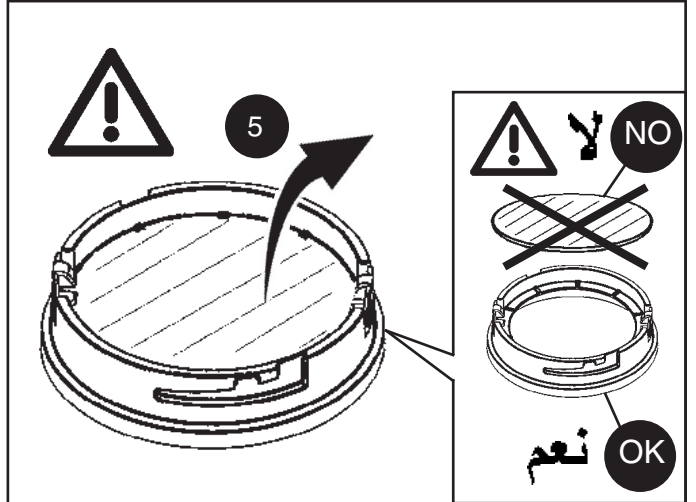
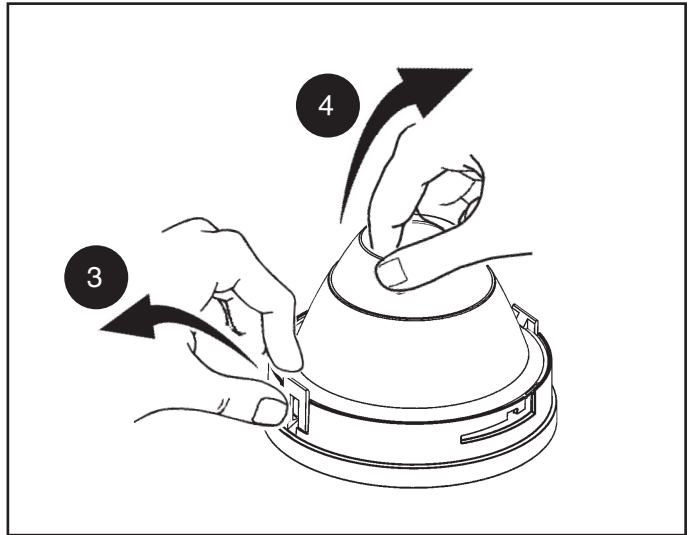
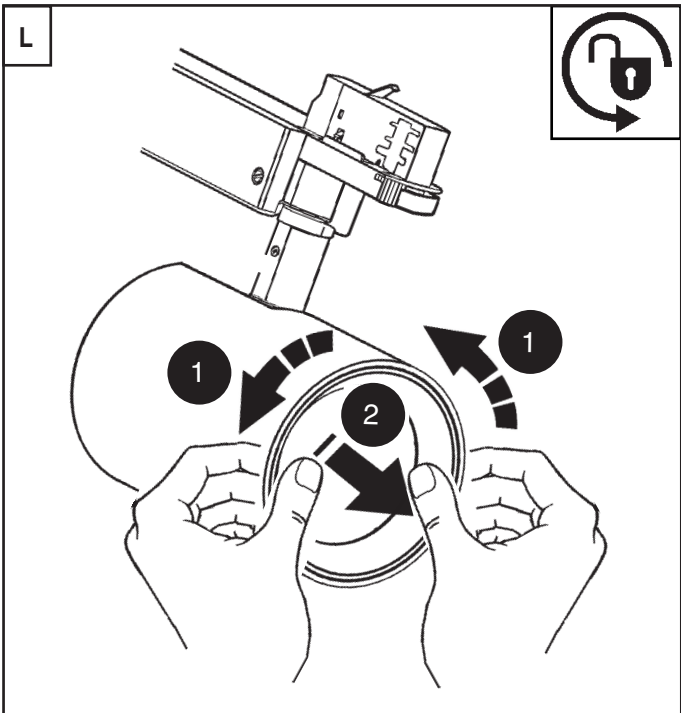
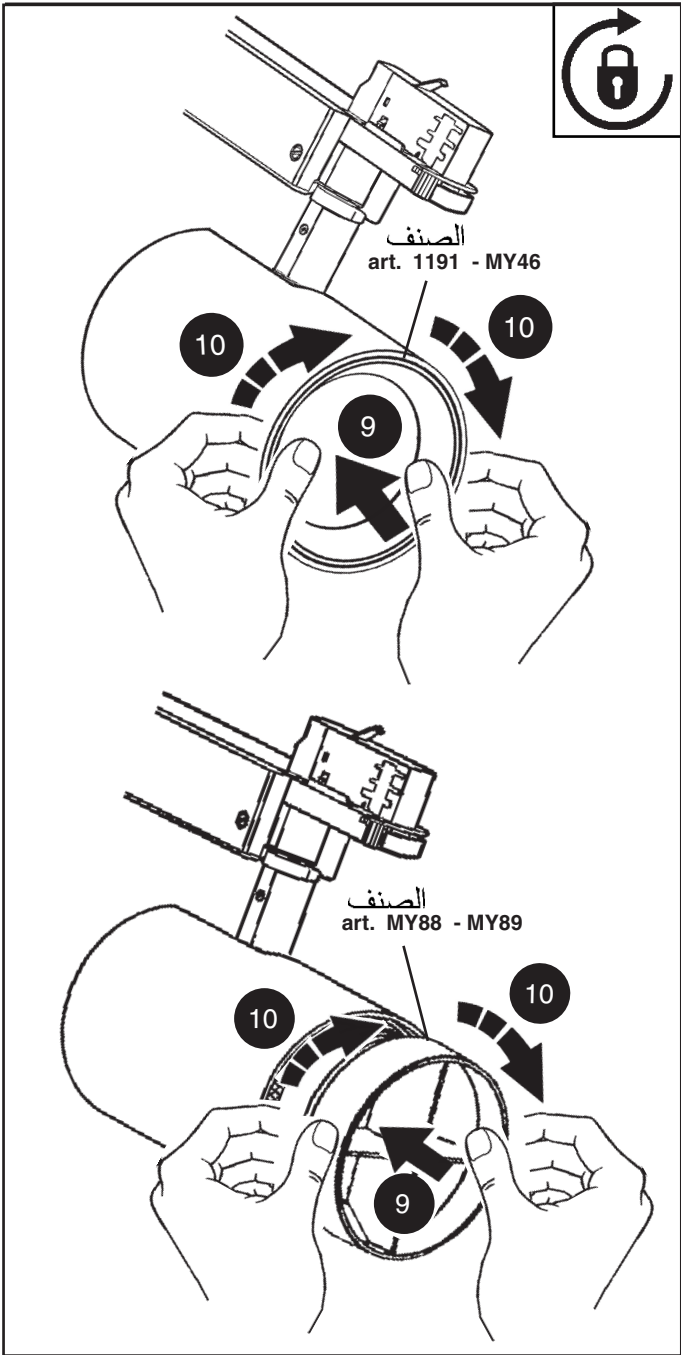

نعم

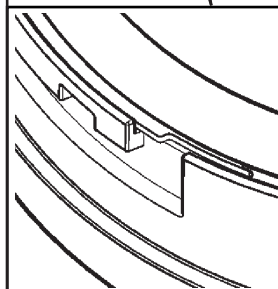
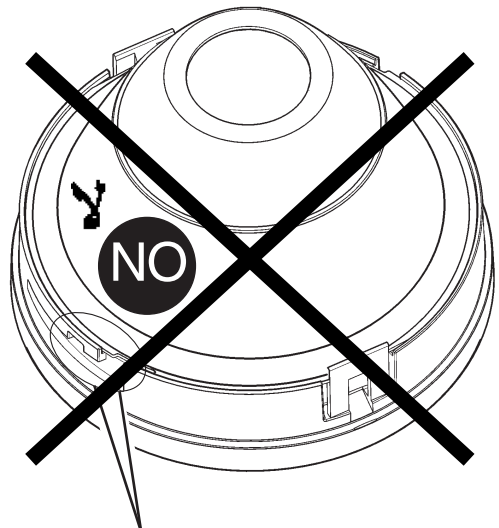
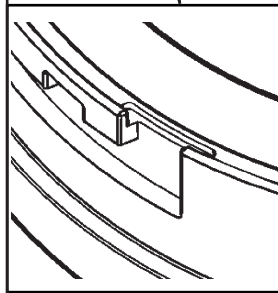
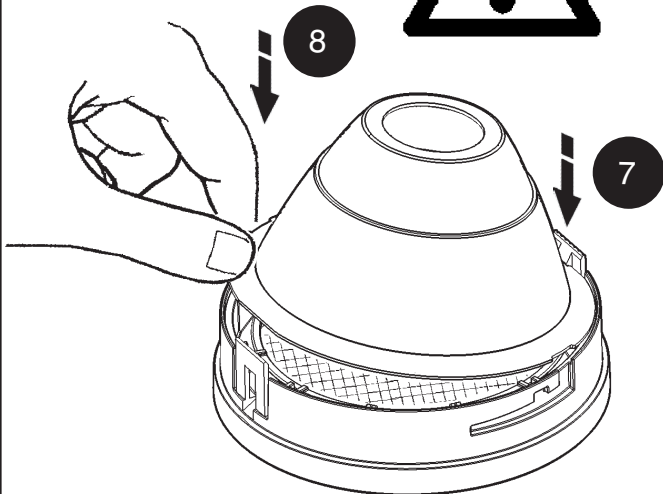
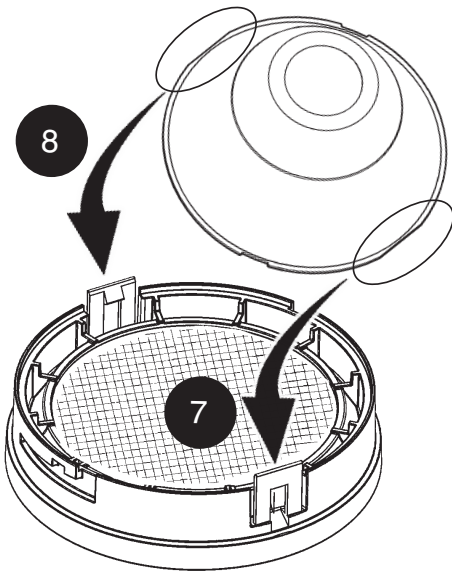
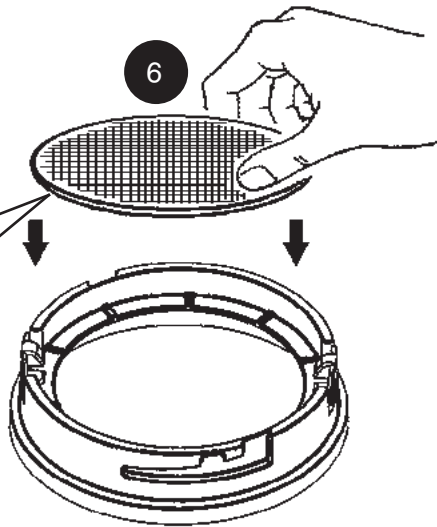
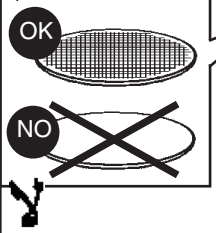

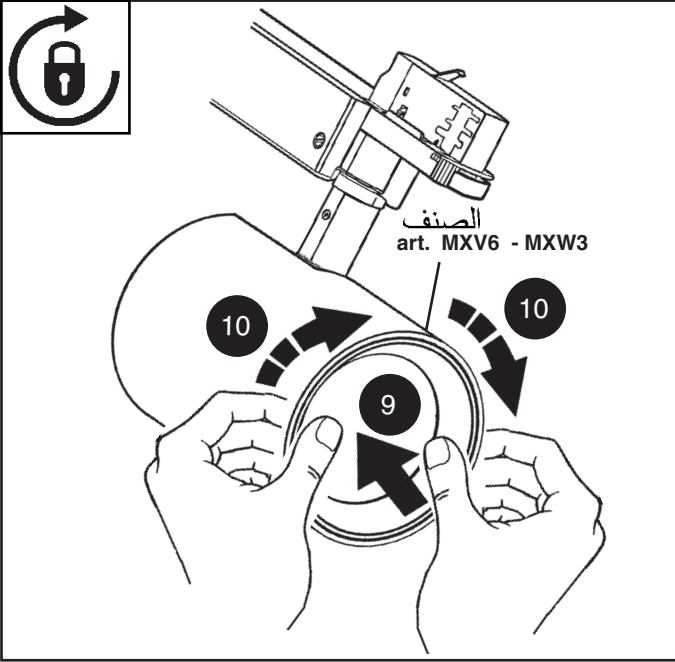

## استبدال الضوء LED

SOSTITUZIONE DEL LED  
REPLACING THE LED  
REEMPLAZO DEL LED

**تنبيه: لاستبدال الضوء LED اتصل بشركة iGuzzini .**

- I N.B.: Per la sostituzione del LED contattare l'azienda iGuzzini.
- GB N.B.: For information on LED replacement please contact iGuzzini.
- E NOTA: Para sustituir el LED llame a la empresa iGuzzini.



### زجاج SODA-LIME الحراري

VETRO SODICO-CALCICO TEMPRATO  
TEMPERED SODA-LIME GLASS  
CRISTAL SÓDICO-CALCÁREO TEMPLADO

لا يمكن استعمال المنتج في حالة كسر الزجاج، وبالتالي يجب الاتصال بتصنيع لاستبداله.

- I In caso di rottura del vetro il prodotto non può essere utilizzato, contattare il costruttore per la sua sostituzione.
- GB Should the glass break, the product cannot be used and you should contact the manufacturer for its replacement.
- E No utilizar el producto en caso de ruptura del vidrio y contactar el fabricante para la sustitución.

2.519.604.00  
IS11579/00

# iGuzzini

POSIZIONE DI INSTALLAZIONE ADATTATORE  
ADAPTER INSTALLATION POSITION  
POSITION D'INSTALLATION ADAPTATEUR  
EINBAUPOSITION DES ADAPTERS  
INSTALLATIESTAND ADAPTER  
POSICIÓN DE INSTALACIÓN DEL ADAPTADOR  
POSITION TIL ADAPTERENS INSTALLATION  
INSTALLASJONSPOSISJON FOR ADAPTER  
INSTALLATIONSPOSITION FÖR ADAPTER  
ПОЛОЖЕНИЕ МОНТАЖА ПЕРЕХОДНИКА  
适配器安装位置

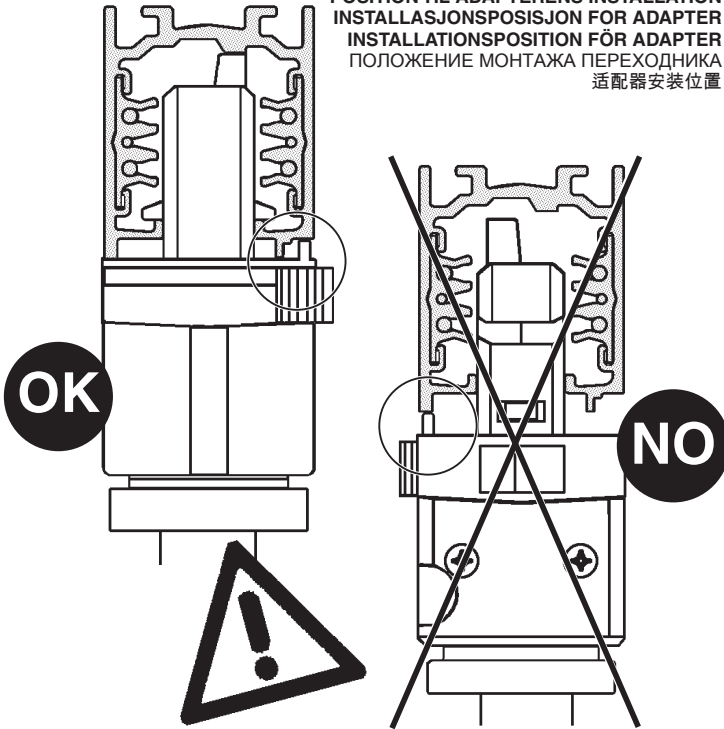

2.519.604.00  
IS11579/00

# iGuzzini

POSIZIONE DI INSTALLAZIONE ADATTATORE  
ADAPTER INSTALLATION POSITION  
POSITION D'INSTALLATION ADAPTATEUR  
EINBAUPOSITION DES ADAPTERS  
INSTALLATIESTAND ADAPTER  
POSICIÓN DE INSTALACIÓN DEL ADAPTADOR  
POSITION TIL ADAPTERENS INSTALLATION  
INSTALLASJONSPOSISJON FOR ADAPTER  
INSTALLATIONSPOSITION FÖR ADAPTER  
ПОЛОЖЕНИЕ МОНТАЖА ПЕРЕХОДНИКА  
适配器安装位置

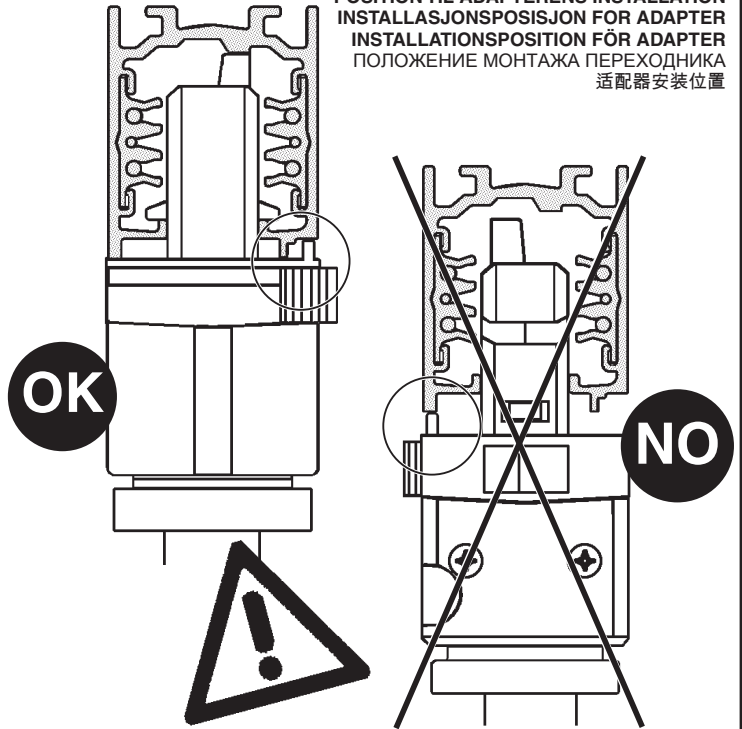

2.519.604.00  
IS11579/00

# iGuzzini

POSIZIONE DI INSTALLAZIONE ADATTATORE  
ADAPTER INSTALLATION POSITION  
POSITION D'INSTALLATION ADAPTATEUR  
EINBAUPOSITION DES ADAPTERS  
INSTALLATIESTAND ADAPTER  
POSICIÓN DE INSTALACIÓN DEL ADAPTADOR  
POSITION TIL ADAPTERENS INSTALLATION  
INSTALLASJONSPOSISJON FOR ADAPTER  
INSTALLATIONSPOSITION FÖR ADAPTER  
ПОЛОЖЕНИЕ МОНТАЖА ПЕРЕХОДНИКА  
适配器安装位置

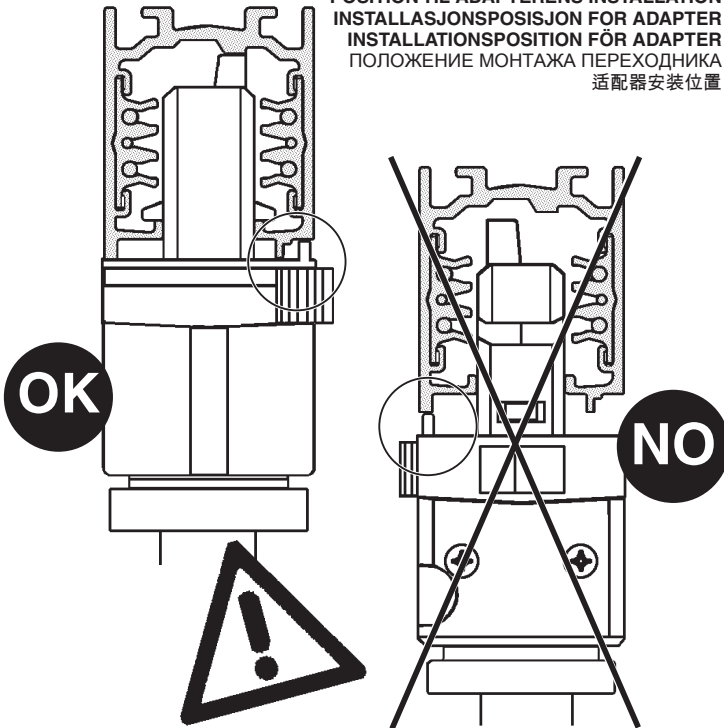

2.519.604.00  
IS11579/00

# iGuzzini

POSIZIONE DI INSTALLAZIONE ADATTATORE  
ADAPTER INSTALLATION POSITION  
POSITION D'INSTALLATION ADAPTATEUR  
EINBAUPOSITION DES ADAPTERS  
INSTALLATIESTAND ADAPTER  
POSICIÓN DE INSTALACIÓN DEL ADAPTADOR  
POSITION TIL ADAPTERENS INSTALLATION  
INSTALLASJONSPOSISJON FOR ADAPTER  
INSTALLATIONSPOSITION FÖR ADAPTER  
ПОЛОЖЕНИЕ МОНТАЖА ПЕРЕХОДНИКА  
适配器安装位置

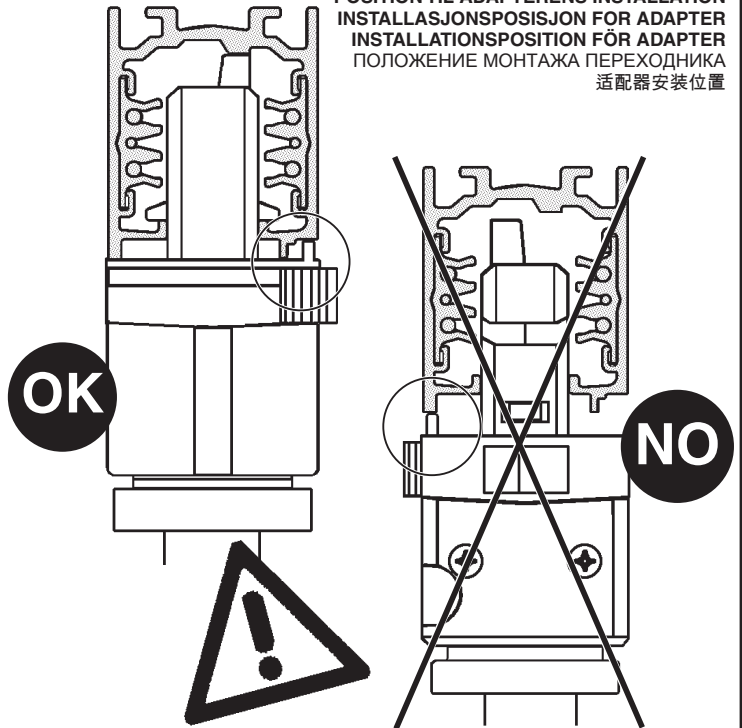

2.518.965.03 ISO8625/03	fattore di potenza power factor facteur de puissance Leistungsfaktor vermogensfactor factor de potencia effektfaktor effektfaktor effektfaktor фактор мощности 功率因数	corrente assorbita absorbed current courant absorbé Stromaufnahme stroomopname corriente absorbida absorberet strøm absorbert strøm tillförd ström поглощаемая мощность 电源电流 (A)
ART.		
MR90 - N351 - N353 - N355	> 0,95	0,11
MR91 - N352 - N354 - N356	> 0,95	0,13
P654 - P655	> 0,95	0,059
P656 - P657	> 0,95	0,071
P658 - P659	> 0,9	0,06
P660 - P661	> 0,9	0,071
P662 - P663 - P664 - P665	> 0,95	0,108
P666 - P667 - P668 - P669	> 0,95	0,103
P670 - P671 - P672 - P673	> 0,95	0,106
P674 - P675 - P676 - P677	> 0,95	0,127
P678	> 0,95	0,146
P679 - P680 - P681 P695 - P696 - P697	> 0,95	0,161
P682	> 0,95	0,151
P683 - P684 - P685	> 0,95	0,165
P686	> 0,95	0,155
P687 - P688 - P689	> 0,95	0,2
P690	> 0,95	0,143
P691 - P692 - P693	> 0,95	0,156
P694	> 0,95	0,148
P698	> 0,95	0,152
P699 - P700 - P701	> 0,95	0,159

2.518.965.03 ISO8625/03	fattore di potenza power factor facteur de puissance Leistungsfaktor vermogensfactor factor de potencia effektfaktor effektfaktor effektfaktor фактор мощности 功率因数	corrente assorbita absorbed current courant absorbé Stromaufnahme stroomopname corriente absorbida absorberet strøm absorbert strøm tillförd ström поглощаемая мощность 电源电流 (A)
ART.		
MR90 - N351 - N353 - N355	> 0,95	0,11
MR91 - N352 - N354 - N356	> 0,95	0,13
P654 - P655	> 0,95	0,059
P656 - P657	> 0,95	0,071
P658 - P659	> 0,9	0,06
P660 - P661	> 0,9	0,071
P662 - P663 - P664 - P665	> 0,95	0,108
P666 - P667 - P668 - P669	> 0,95	0,103
P670 - P671 - P672 - P673	> 0,95	0,106
P674 - P675 - P676 - P677	> 0,95	0,127
P678	> 0,95	0,146
P679 - P680 - P681 P695 - P696 - P697	> 0,95	0,161
P682	> 0,95	0,151
P683 - P684 - P685	> 0,95	0,165
P686	> 0,95	0,155
P687 - P688 - P689	> 0,95	0,2
P690	> 0,95	0,143
P691 - P692 - P693	> 0,95	0,156
P694	> 0,95	0,148
P698	> 0,95	0,152
P699 - P700 - P701	> 0,95	0,159

2.518.965.03 ISO8625/03	fattore di potenza power factor facteur de puissance Leistungsfaktor vermogensfactor factor de potencia effektfaktor effektfaktor effektfaktor фактор мощности 功率因数	corrente assorbita absorbed current courant absorbé Stromaufnahme stroomopname corriente absorbida absorberet strøm absorbert strøm tillförd ström поглощаемая мощность 电源电流 (A)
ART.		
MR90 - N351 - N353 - N355	> 0,95	0,11
MR91 - N352 - N354 - N356	> 0,95	0,13
P654 - P655	> 0,95	0,059
P656 - P657	> 0,95	0,071
P658 - P659	> 0,9	0,06
P660 - P661	> 0,9	0,071
P662 - P663 - P664 - P665	> 0,95	0,108
P666 - P667 - P668 - P669	> 0,95	0,103
P670 - P671 - P672 - P673	> 0,95	0,106
P674 - P675 - P676 - P677	> 0,95	0,127
P678	> 0,95	0,146
P679 - P680 - P681 P695 - P696 - P697	> 0,95	0,161
P682	> 0,95	0,151
P683 - P684 - P685	> 0,95	0,165
P686	> 0,95	0,155
P687 - P688 - P689	> 0,95	0,2
P690	> 0,95	0,143
P691 - P692 - P693	> 0,95	0,156
P694	> 0,95	0,148
P698	> 0,95	0,152
P699 - P700 - P701	> 0,95	0,159

2.518.965.03 ISO8625/03	fattore di potenza power factor facteur de puissance Leistungsfaktor vermogensfactor factor de potencia effektfaktor effektfaktor effektfaktor фактор мощности 功率因数	corrente assorbita absorbed current courant absorbé Stromaufnahme stroomopname corriente absorbida absorberet strøm absorbert strøm tillförd ström поглощаемая мощность 电源电流 (A)
ART.		
MR90 - N351 - N353 - N355	> 0,95	0,11
MR91 - N352 - N354 - N356	> 0,95	0,13
P654 - P655	> 0,95	0,059
P656 - P657	> 0,95	0,071
P658 - P659	> 0,9	0,06
P660 - P661	> 0,9	0,071
P662 - P663 - P664 - P665	> 0,95	0,108
P666 - P667 - P668 - P669	> 0,95	0,103
P670 - P671 - P672 - P673	> 0,95	0,106
P674 - P675 - P676 - P677	> 0,95	0,127
P678	> 0,95	0,146
P679 - P680 - P681 P695 - P696 - P697	> 0,95	0,161
P682	> 0,95	0,151
P683 - P684 - P685	> 0,95	0,165
P686	> 0,95	0,155
P687 - P688 - P689	> 0,95	0,2
P690	> 0,95	0,143
P691 - P692 - P693	> 0,95	0,156
P694	> 0,95	0,148
P698	> 0,95	0,152
P699 - P700 - P701	> 0,95	0,159



2.509.493.00  
IS11580/00

**iGuzzini**

موضع تركيب المهايئ

POSIZIONE DI INSTALLAZIONE ADATTATORE  
ADAPTER INSTALLATION POSITION  
POSICIÓN DE INSTALACIÓN DEL ADAPTADOR

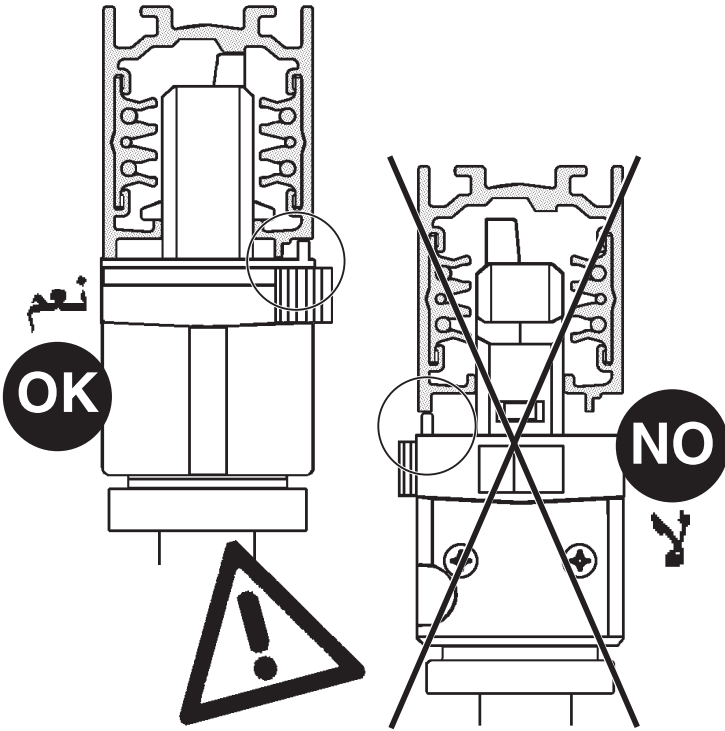

2.509.493.00  
IS11580/00

**iGuzzini**

موضع تركيب المهايئ

POSIZIONE DI INSTALLAZIONE ADATTATORE  
ADAPTER INSTALLATION POSITION  
POSICIÓN DE INSTALACIÓN DEL ADAPTADOR

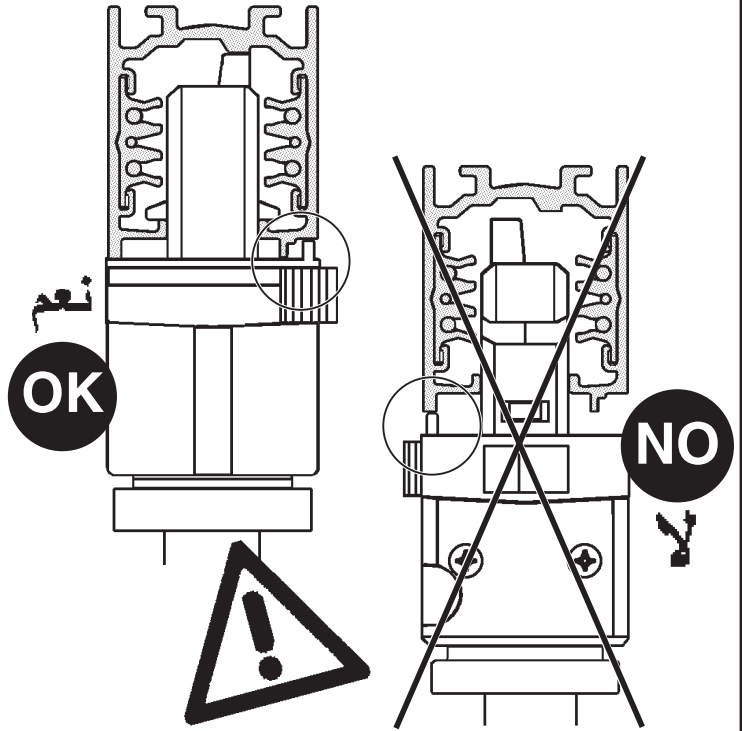

2.509.493.00  
IS11580/00

**iGuzzini**

موضع تركيب المهايئ

POSIZIONE DI INSTALLAZIONE ADATTATORE  
ADAPTER INSTALLATION POSITION  
POSICIÓN DE INSTALACIÓN DEL ADAPTADOR

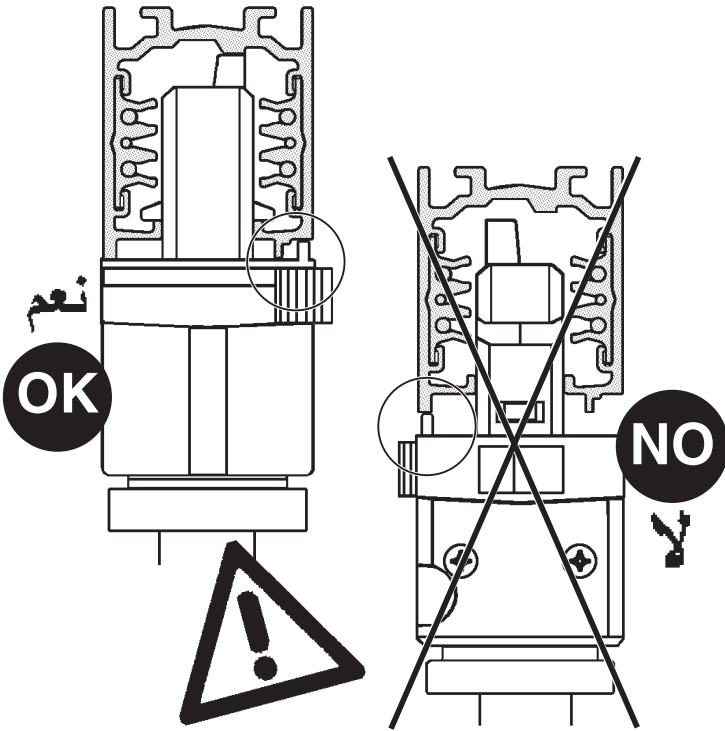

2.509.493.00  
IS11580/00

**iGuzzini**

موضع تركيب المهايئ

POSIZIONE DI INSTALLAZIONE ADATTATORE  
ADAPTER INSTALLATION POSITION  
POSICIÓN DE INSTALACIÓN DEL ADAPTADOR

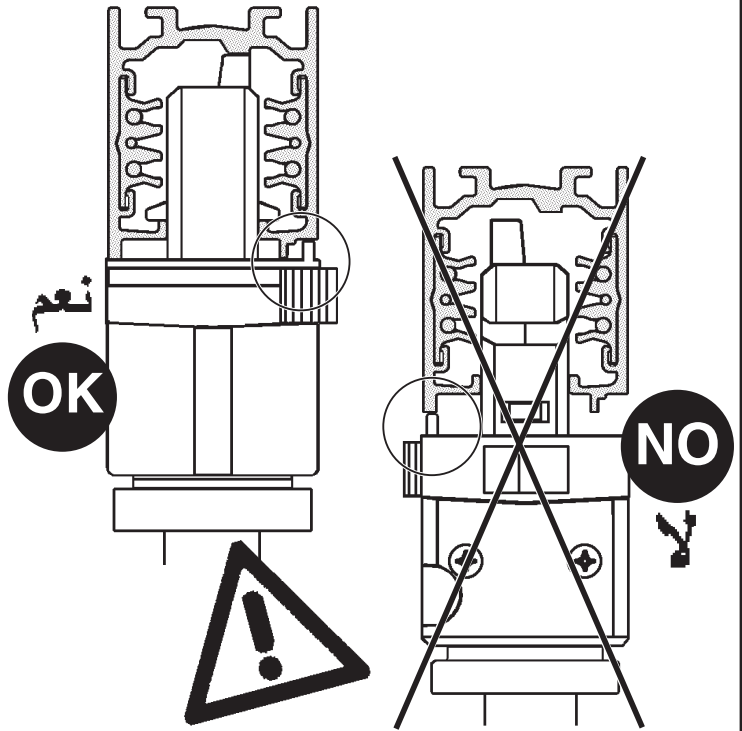

- I Istruzioni per le operazioni di servizio per l'apparecchio di illuminazione**  
**GB Instructions on luminaire service operations**  
**F Instructions pour les opérations de service du luminaire**  
**D Wartungsanleitung für die Leuchte**  
**NL Instructies voor de onderhoudsoperaties op de verlichtingsarmatuur**  
**E Instrucciones para las operaciones de servicio del aparato de alumbrado**  
**DK Anvisninger i serviceindgreb på belysningsarmatur**  
**N Anvisninger for betjening av lysapparatet**  
**S Instruktioner för användning av belysningsanordningen**  
**RUS Инструкции по эксплуатации осветительного прибора**  
**CN 照明装置检修操作说明**

**Sostituire la lampada parzialmente esausta**  
 Replace the partly exhausted lamp  
 Remplacer la lampe partiellement épuisée  
 Die teilweise erschöpfte Lampe austauschen  
 Vervang de gedeeltelijk lege lamp  
 Sustituir la lámpara parzialmente agotada  
 Udskift den delvist udtjente pære  
 Skifte ut den delvis utbrente lyspæren  
 Byt ut den delvis förbrukade lampan  
 Замена частично отработанной лампочки  
 更换部分老化的灯泡



**Spegnimento**  
 Switch it off  
 Extinction  
 Ausschaltung  
 Uitschakeling  
 Apagado  
 Slukning  
 Slukking  
 Släckning  
 Выключение  
 关灯

**Interrompere l'alimentazione dell'apparecchio**  
 Cut the power supply to the luminaire  
 Couper l'alimentation du luminaire  
 Stromversorgung der Leuchte unterbrechen  
 Onderbreek de voeding van het apparaat  
 Interrumpir la alimentación del aparato  
 Afbryd armaturets strømforsyning  
 Avbryt strømtilførselen til apparatet  
 Koppla från anordningens strömförsörjning  
 Отключить электропитание прибора  
 中断装置供电



**Aprire l'apparecchio**  
 Open the fixture  
 Ouvrir le luminaire  
 Das Gerät öffnen  
 Open het apparaat  
 Abrir el aparato  
 Åbn armaturet  
 Åpne apparatet  
 Öppna anordningen  
 Раскрыть прибор  
 打开装置

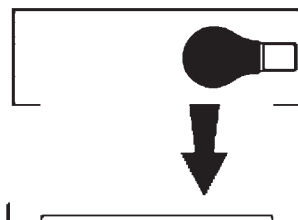

**Rimuovere la lampada esausta**  
 Remove the exhausted lamp  
 Retirer la lampe épuisée  
 Die alte Lampe entnehmen  
 Verwijder de lege lamp  
 Quitar la lámpara agotada  
 Tag den udtjente pære ud  
 Fjerne den utbrente lyspæren  
 Ta bort den förbrukade lampan  
 Вынуть старую лампочку  
 取出老化的灯泡

**Portarla in un centro di riciclaggio**  
 Carry it to a recycling centre  
 La porter dans une déchetterie pour son recyclage  
 Ordnungsgemäß entsorgen  
 Breng de lamp naar een recyclingcentrum  
 Llevarla a un centro de reciclaje  
 Aflever den på en genbrugsstation  
 Lever den til en miljøstasjon  
 Lämna in den till en återvinningsanläggning  
 Сдать ее в пункт приема утильсырья  
 将其送往回收中心



**Inserire la nuova lampada**  
 Introduce the new lamp  
 Installer la lampe neuve  
 Die neue Lampe einsetzen  
 Doe de nieuwe lamp op zijn plek  
 Montar la nueva lámpara  
 Sæt den nye pære i  
 Sette i den nye pæren  
 Sätt i den nya lampan  
 Вставить новую лампочку  
 装入新灯泡

**Inserire la nuova lampada nel portalampada**  
 Fit the new lamp into the socket  
 Installer la nouvelle lampe dans le support de lampe  
 Die neue Lampe in den Sockel einsetzen  
 Doe de nieuwe lamp in de lamphouder  
 Montar la nueva lámpara en el portalámpara  
 Sæt den nye pære i fatningen  
 Sette den nye pæren inn i lampeholderen  
 Sätt i den nya lampan i lamphållaren  
 Вставить новую лампочку в патрон  
 将新灯泡插入灯泡架中



**Riposizionare ottica**  
 Re-place the optic  
 Remettre l'optique à sa place  
 Die Optik wieder einsetzen  
 Doe de optiek weer op zijn plaats  
 Volver a montar la óptica  
 Sæt den optiske enhed på plads  
 Innstille linsen  
 Flytta om optiken  
 Отрегулировать линзы  
 重新定位光头



**Effettuare prova di funzionamento**  
 Perform operative test  
 Procéder à un essai de fonctionnement  
 Eine Funktionsprüfung durchführen  
 Controleer de correcte werking  
 Hacer una prueba de funcionamiento  
 Afprøv funktionen  
 Prøve om den fungerer  
 Utför funktionstest  
 Выполнить проверку исправности работы  
 执行功能测试



**I Istruzioni per la pulizia dell'apparecchio di illuminazione**  
**GB Instructions on luminaire cleaning operations**  
**F Instructions pour le nettoyage du luminaire**  
**D Anweisungen zur Reinigung der Leuchte**  
**NL Instructies voor de reiniging van de verlichtingsarmatuur**  
**E Instrucciones para limpiar el aparato de alumbrado**  
**DK Anvisninger i rengøring af belysningsarmaturet**  
**N Anvisninger for rengjøring av lysapparatet**  
**S Instruktioner för rengöring av belysningsanordningen**  
**RUS Инструкции по чистке осветительного прибора**  
**CN 照明装置清洁说明**

**Pulire l'apparecchio**  
 Clean the fixture  
**Nettoyer le luminaire**  
 Das Gerät reinigen  
**Reinig het apparaat**  
 Limpiar el aparato  
**Rengør armaturet**  
**Rengjøre apparatet**  
**Rengör anordningen**  
 Чистка прибора  
 清洁装置



**Spegnimento**  
 Switch it off  
**Extinction**  
**Ausschaltung**  
**Uitschakeling**  
**Apagado**  
**Slukning**  
**Slukking**  
**Släckning**  
**Выключение**  
 关灯

Interrompere l'alimentazione dell'apparecchio  
 Cut the power supply to the luminaire  
 Couper l'alimentation du luminaire  
 Stromversorgung der Leuchte unterbrechen  
 Onderbreek de voeding van het apparaat  
 Interrumpir la alimentación del aparato  
 Afbryd armaturets strømforsyning  
 Avbryt strømtilførselen til apparatet  
 Koppla från anordningens strömförsörjning  
 Отключить электропитание прибора  
 中断装置供电



**Spolverare l'ottica esterna**  
 Remove dust from the external optic  
**Dépoussiérer l'optique extérieure**  
**Die externe Optik abstauben**  
**Stof de externe optiek af**  
**Quitar el polvo de la óptica exterior**  
**Tør støvet af den udvendige optiske enhed**  
**Fjerne støv fra den eksterne lysenheten**  
**Damma av den yttre optiken**  
**Вытереть пыль с внешней стороны линз**  
 为外侧光头掸尘



**Lavare l'ottica esterna**  
 Wash the external optic  
**Laver l'optique extérieure**  
**Die externe Optik waschen**  
**Was de externe optiek**  
**Lavar la óptica exterior**  
**Vask den udvendige optiske enhed**  
**Vaske den eksterne lysenheten**  
**Rengör den yttre optiken**  
**Вымыть линзы с внешней стороны**  
 清洁外光头



**Rimuovere l'ottica**  
 Remove the optic  
**Retirer l'optique**  
**Die Optik abnehmen**  
**Verwijder de optiek**  
**Quitar la óptica**  
**Tag den optiske enhed af**  
**Fjerne lysenheten**  
**Ta bort optiken**  
**Снять линзы**  
 取下光头

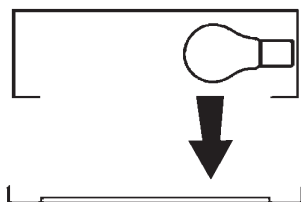

**Pulire la parte interna dell'apparecchio di illuminazione**  
 Clean the inside of the fixture  
**Nettoyer l'intérieur du luminaire**  
**Die Innenseite der Leuchte reinigen**  
**Reinig de binnenzijde van de verlichtingsarmatuur**  
**Limpiar el interior del aparato de alumbrado**  
**Rengør belysningsarmaturets indvendige dele**  
**Rengjøre lysapparatet innvendig**  
**Rengör belysningsanordningen invändigt**  
**Протереть осветительный прибор изнутри**  
 清洁照明装置内部



**Riposizionare ottica**  
 Re-place the optic  
**Remettre l'optique à sa place**  
**Die Optik wieder einsetzen**  
**Doe de optiek weer op zijn plaats**  
**Volver a montar la óptica**  
**Sæt den optiske enhed på plads**  
**Innstille linsen**  
**Flytta om optiken**  
**Отрегулировать линзы**  
 重新定位光头

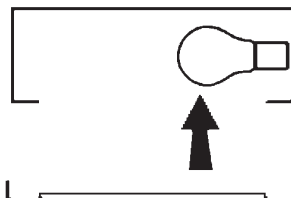

**Effettuare prova di funzionamento**  
 Perform operative test  
**Procéder à un essai de fonctionnement**  
**Eine Funktionsprüfung durchführen**  
**Controleer de correcte werking**  
**Hacer una prueba de funcionamiento**  
**Afprøv funktionen**  
**Prøve om den fungerer**  
**Utför funktionstest**  
**Выполнить проверку исправности работы**  
 执行功能测试

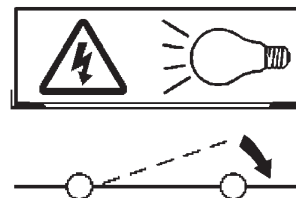

- I** Istruzioni per il fine vita e lo smaltimento dei componenti  
**GB** Instructions on end-of-life and component disposal  
**F** Instructions pour la gestion des composants en fin de vie et leur mise au rebut  
**D** Anweisungen zur Entsorgung der Leuchtenkomponenten  
**NL** Instructies voor het verwijderen van de armatuur en het recyclen van de onderdelen  
**E** Instrucciones para el final de vida y la eliminación los componentes  
**DK** Anvisninger i udtjent armatur og bortskaffelse af komponenter  
**N** Anvisninger for endt levetid og avfallsbehandling av delene  
**S** Instruktioner vid bortskaffning och kassering av komponenter  
**RUS** Инструкции по утилизации прибора и его комплектующих по окончании его срока службы  
**CN** 寿命期结束与零件废弃处置说明

<p>Spegnimento Switch it off Extinction Ausschaltung Uitschakeling Apagado Slukning Slukking Släckning Выключение 关灯</p> <p>Interrompere l'alimentazione dell'apparecchio Cut the power supply to the luminaire Couper l'alimentation du luminaire Stromversorgung der Leuchte unterbrechen Onderbreek de voeding van het apparaat Interrompirla alimentación del aparato Afbryd armaturets strømforsyning Avbryt strømtilførselen til apparatet Koppla från anordningens strömförsörjning Отключить электропитание прибора 中断装置供电</p> 	<p>Rimuovere la/e lampada/e per la dismissione Remove the lamp(s) for decommissioning Retirer la(les) lampe(s) pour sa(leur) mise au rebut Die Lampe/n ordnungsgemäß entsorgen Verwijder de lamp(en) voor het recyclen Quitar la(s) lámpara(s) para el desecho Tag pæren/pærerne ud til bortskaffelse Fjerne lampen/-e som skal kastes Ta bort lampan/-orna för bortskaffningen Вынуть лампочку/и для утилизации прибора 取出需要丢弃的灯泡</p> 	<p>Rimuovere la batteria per la dismissione Remove the battery for decommissioning Retirer la batterie pour sa mise au rebut Die Batterie ordnungsgemäß entsorgen Verwijder de batterij voor het recyclen Quitar la batería para el desecho Tag batteriet ud til bortskaffelse Fjerne batteriet som skal kastes Ta bort batteriet för bortskaffningen Вынуть батарейку для утилизации прибора 取出需要丢弃的电池</p> 	<p>Rimuovere l'apparecchio per la dismissione Remove the fixture for decommissioning Enlever le luminaire pour sa mise au rebut Das Gerät ordnungsgemäß entsorgen Verwijder het apparaat voor het recyclen Quitar el aparato para el desecho Tag armaturet ud til bortskaffelse Fjerne apparatet som skal kastes Ta bort anordningen för bortskaffningen Снять прибор для утилизации 取出需要丢弃的装置</p> 
---	--	--	--

<p>Inviare i materiali ad un centro di raccolta RAEE Send the materials to a WEEE collection centre Envoyer les matériaux dans une déchetterie DEEE Die Materialien in einem WEEE-Zentrum entsorgen Zend de materialen naar een recyclingscentrum voor de AEEA Enviar los materiales a un centro de recogida RAEE Afløver materialerne på et indsamlingscenter for elektronisk udstyr Sende materialene til en miljøstasjon for resirkulering av EE-avfall Skicka materialet till en RAEE uppsamlingscentral Сдать материалы в пункт приема утильсырья 将材料送往电气和电子垃圾回收中心</p> 			
--	--	--	--