

## LIGHT UP EARTH



### ATTENZIONE:

LA SICUREZZA DELL'APPARECCHIO E' GARANTITA SOLO CON L'USO APPROPRIATO DELLE SEGUENTI ISTRUZIONI; PERTANTO E' NECESSARIO CONSERVARLE.

### GB WARNING:

THE SAFETY OF THIS FIXTURE IS GUARANTEED ONLY IF YOU COMPLY WITH THESE INSTRUCTIONS; REMEMBER TO CONSERVE IN A SAFE PLACE.

### F ATTENTION:

LA SECURITE DE L'APPAREIL N'EST GARANTIE QU'EN CAS D'UTILISATION CORRECTE DES INSTRUCTIONS SUIVANTES; IL FAUT PAR CONSEQUENT LES CONSERVER.

### D ACHTUNG:

DIE SICHERHEIT DES GERÄTES WIRD NUR DURCH SACHGEMÄSSE BEFOLGUNG NACHSTEHENDER ANWEISUNGEN GEWÄHRLEISTET; IHRE AUFBEWAHRUNG IST DESHALB SEHR WICHTIG.

### NL OPGELET:

DE VEILIGHEID VAN DI TOESTEL IS SLECHTS DAN GEGARANDEERD ALS INDIEN DE VOLGENDE INSTRUCTIES STRIKT WORDEN TOEGEPAST: DAAROM MOET MEN ZE OOK BEWAAREN.

### E ATENCION:

LA SEGURIDAD DEL APARATO SE GARANTIZA SOLO CUMPLIENDO CUIDADOSAMENTE LAS SIGUIENTES INSTRUCCIONES; POR ELLO, ES NECESARIO CONSERVARLAS.

### DK BEMÆRK:

SIKKERHEDEN VED BRUG AF ARMATURET KAN KUN GARANTERES, HVIS DISSE ANVISNINGER FØLGES; SØRG DERFOR FOR AT GEMME DEM.

### N ADVARSEL:

SIKKERHETEN TIL DETTE APPARATET GARANTERES KUN HVIS DU OVERHOLDER DISSE INSTRUKSJONENE; HUSK Å OPPBEVARE DEM PÅ ET TRYGT STED.

### S OBSERVERA!

UTRUSTNINGENS SÄKERHET KAN ENDAST GARANTERAS OM DESSA ANVISNINGAR RESPEKTERAS I DETALJ. SPARA DÄRFÖR DESSA ANVISNINGAR FÖR FRAMTIDA KONSULTATION.

### RUS ВНИМАНИЕ:

МЫ ГАРАНТИРУЕМ БЕЗОПАСНУЮ ЭКСПЛУАТАЦИЮ ИЗДЕЛИЯ ТОЛЬКО ПРИ СОБЛЮДЕНИИ СЛЕДУЮЩИХ ИНСТРУКЦИЙ; С ЭТОЙ ЦЕЛЬЮ НЕОБХОДИМО СОХРАНИТЬ ДАННУЮ БРОШЮРУ.

### CN 警告

为确保该装置安全，请遵守操作指示；并于安全场所放置。

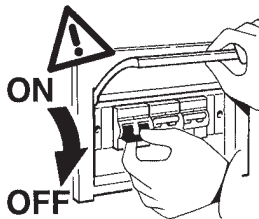

I N.B.: Apparecchi non idonei ad essere coperti di materiale termicamente isolante

GB N.B.: Fixtures not suitable to be covered in thermally-insulating material.

F N.B.: Appareils ne pouvant pas être couverts de matériau d'isolation thermique

D N.B.: Geräte nicht geeignet, um mit wärmeisolierendem Material abgedeckt zu werden

NL N.B.: Deze apparaten zijn niet geschikt om te worden bedekt met thermisch isolerend materiaal

E NOTA: Aparatos no aptos para ser cubiertos de material térmicamente aislante

DK N.B.: Armaturerne må ikke dækkes af varmeisolerende materiale.

N N.B.: Apparaten passer ikke til å dekkes av termoisolerende materialer.

S OBS! Utrustningen får inte täckas över med värmeisolerande material

RUS Внимание: Приборы непригодны для покрытия термоизоляционным материалом.

CN 灯具不适用隔热材料加以覆盖。

N.B.: DURANTE L'INSTALLAZIONE DEL SISTEMA RISPETTARE SCRUPOLOSAMENTE LE NORME IMPIANTISTICHE NAZIONALI VIGENTI.

N.B.: WHEN INSTALLING THE SYSTEM, MAKE SURE ALL CURRENT NATIONAL REGULATIONS RELATING TO INSTALLATION ARE OBSERVED.

N.B.: LORS DE L'INSTALLATION DU SYSTÈME VEUILLEZ RESPECTER RIGOREUSEMENT LES NORMES EN VIGUEUR EN LA MATIÈRE DANS LE PAYS.

N.B.: BEACHTEN SIE BEI DER INSTALLATION DES SYSTEMS UNBEDINGT DIE IM LAND GELTENDEN ANLAGETECHNISCHEN VORSCHRIFTEN.

N.B.: BIJ HET INSTALLEREN VAN HET SYSTEEM MOET U DE GELDENDE NATIONALE INSTALLATIENORMEN STRIKT NALEVEN.

NOTA: DURANTE LA INSTALACIÓN DEL SISTEMA RESPETAR ESCRUPULOSAMENTE LAS NORMAS NACIONALES DE INSTALACIÓN EN VIGOR.

N.B.: UNDER INSTALLATION OF SYSTEMET SKAL MAN NØJE OVERHOLDE DE GÆLDENDE REGLER FOR DISSE ANLÆG.

N.B.: UNDER INSTALLASJON AV SYSTEMET MÅ DE NASJONALE ANLEGGSFORSKRIFTENE OVERHOLDES NØYE.

OBS! UNDER INSTALLATIONEN AV SYSTEMET SKA GÄLLANDE NATIONELLA INSTALLATIONSFÖRESKRIFTER RESPEKTERAS I DETALJ.

ПРИМЕЧАНИЕ: В ПРОЦЕССЕ МОНТАЖА СИСТЕМЫ СТРОГО СОБЛЮДАЙТЕ НАЦИОНАЛЬНЫЕ ДЕЙСТВУЮЩИЕ НОРМАТИВЫ ПО ЭЛЕКТРОПРОВОДКЕ.

注意：安装系统时请务必遵守系统标准。

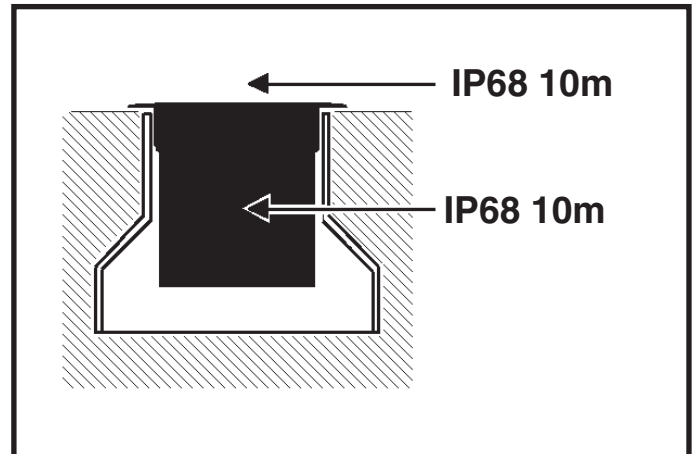

I Gli apparecchi sono stati progettati e collaudati per reggere un carico statico fino a 50000 N e resistere alle sollecitazioni di percorrenza. L'installazione non è ammessa in zone di utilizzo di spalaneve e con carrabilità a velocità superiori ai 50 Km/h.

GB The lighting fixtures were designed and tested to withstand a static load of up to 50000 N and to resist drive-over stress. The fixtures may not be installed in areas where snowplows are used, or where the drive-over speed exceeds 50 km/h.

F Les appareils ont été spécialement conçus et testés pour supporter une charge statique pouvant atteindre 50000 N et résister aux contraintes de circulation. L'installation n'est pas permise dans des zones d'utilisation de chasse-neige et où la vitesse de circulation dépasse 50 Km/h.

D Bei der Entwicklung und Prüfung der Leuchten wurde sichergestellt, dass sie einer statischen Belastung von bis zu 50000 N sowie den Belastungen, denen sie auf viel befahrenen Straßen ausgesetzt sind, standhalten. Die Leuchten dürfen nicht in Bereichen installiert werden, in denen Schneeräumfahrzeuge eingesetzt werden, oder auf Straßen, die mit einer Geschwindigkeit von mehr als 50 km/h befahren werden.

NL De apparaten zijn ontworpen en goedgekeurd voor het dragen van een statische lading tot aan 50000 N en het weerstaan van de druk van overgaand verkeer. Installaties in gebieden waar sneeuwplougen worden gebruikt en waar verkeer sneller dan 50 km/h passeert is niet toegestaan.

E Los aparatos han sido proyectados y probados para soportar una carga estática máxima de 50000 N y resistir a los esfuerzos derivados del tránsito. La instalación no está admitida en zonas donde se utilizan máquinas para espalar la nieve y donde esté permitido el tráfico a velocidades superiores a los 50 Km/h.

DK Armaturerne er udviklet og afprøvet til en statisk belastning på op til 50000 N og kan modstå forbipasserende belastninger. Installation er ikke tilladt i områder, hvor der køres snepløve og hvor der køres hurtigere end 50 km/t.

N Lysarmaturer ble designet og testet for å motstå en statisk belastning på inntil 50000 N og motstå overkjøringsbelastning. Armaturerne kan ikke installeres i områder der det brukes snøpløger, eller der overkjøringshastigheten overstiger 50 km/t.

S Utrustningarna har tillverkats och testats för att tåla en statisk belastning på upp till 50000 N och tåla förbipasserande belastningar. Installationen är inte tillåten i områden där snöplög används eller där fordon passerar med en hastighet över 50 km/h.

RUS Приборы спроектированы и испытаны на статическую нагрузку вплоть до 50000 N и выдерживают динамическую нагрузку. Не допускается монтаж в зонах работы

CN 这些装置经过设计并且核查时可以承担最大重量至 50000 N 公斤的，并且能够承受路面载荷。在铲雪车经过以及通车速度时超过50公里的地方不可以安装

I N.B. Si consiglia di effettuare le operazioni d'installazione o di manutenzione all'interno del vano ottico, in ambienti interni o quanto meno in assenza di umidità o pioggia.

**GB** N.B.: Installation and maintenance operations must be carried out inside the optical assembly, indoor and in a place with no humidity or rain.

**F** N.B.: Pour effectuer les opérations d'installation ou d'entretien des composants intérieurs du bloc optique, il est conseillé de se rendre dans un espace clos, ou tout du moins à l'abri de l'humidité ou de la pluie.

**D** Hinweis: Es empfiehlt sich, alle Installations- oder Wartungseingriffe am Leuchtengehäuse in geschlossenen Räumen bzw. bei trockenen Luftverhältnissen vorzunehmen (Feuchtigkeit und Regen vermeiden).

**NL** N.B.: We raden u aan de installatie- of onderhoudshandelingen van de optische behuizing binnenshuis uit te voeren, of in ieder geval in een omgeving waar geen vocht of regen is.

**E** N.B.: Se recomienda efectuar las operaciones de instalación o mantenimiento dentro del cuerpo óptico, en interiores o por lo menos en ausencia de humedad o lluvia.

**DK** N.B. Det anbefales at udføre installation eller vedligeholdelse inden i den optiske enhed indenfor på et område fri for fugt og regn.

**N** N.B.: Det anbefales å utgjøre installasjons- eller vedlikeholdsinngrepene inne i det optiske rommet, innendørs eller i hvert fall der det ikke finnes fuktighet eller regn.

**S** OBS! Det rekommenderas att utföra installations- eller underhållsinsgrepp inuti det optiska rummet inomhus eller åtminstone i avsaknad av fukt eller regn.

**RUS** ПРИМЕЧАНИЕ: Рекомендуется выполнять монтажи или техническое обслуживание внутри лампового отсека в закрытых помещениях или по крайней мере в отсутствие влаги или атмосферных осадков.

**CN** 注释：建议在光学空间内部进行安装或者维修操作至少在内部环境或者不存在雨水或潮湿的环境。



	NO DALI	DALI
Ø 144mm		
Ø 200mm		
Ø 250mm		



I Si consiglia di proteggere adeguatamente il cavo dal contatto diretto con il terreno.

**GB** The cable should be suitably protected against direct contact with the ground.

**F** Nous conseillons de protéger adéquatement le câble du contact direct avec le sol.

**D** Es wird empfohlen, das Kabel ausreichend vor dem direkten Kontakt mit dem Erdbreich zu schützen.

**NL** Geadviseerd wordt om de kabel adequaat te beschermen tegen direct contact met de grond.

**E** Se recomienda proteger adecuadamente el cable del contacto directo con el terreno.

**DK** Det anbefales at beskytte kablet på passende vis mod direkte kontakt med jorden.

**N** Vi anbefaler at kablen beskyttes tilstrekkelig fra kontakt med bakken.

**S** Det rekommenderas att skydda kablarna så att den inte är i direkt kontakt med marken.

**RUS** Рекомендуется защитить надлежащим образом кабель от прямого контакта с землей.

**CN** 建议采取适当的方式保护电缆，防止其与地面直接接触。



I In caso di danneggiamento del cavo flessibile esterno, questo deve essere sostituito dal costruttore, o dal suo servizio di assistenza, o da personale qualificato equivalente, al fine di evitare pericoli.

**GB** Should the outer flexible cable be somehow damaged, the latter should be replaced by the manufacturer, or by the corresponding service centre, or by an appropriate and qualified member of staff in order to avoid all risk of danger.

**F** Si le câble flexible extérieur est abîmé, faites-le remplacer par le fabricant, par son service après-vente ou par un professionnel du secteur agréé afin d'éviter tout danger.

**D** Sollte das äußere Kabel beschädigt sein, so muss es aus Sicherheitsgründen vom Hersteller, dessen Kundendienst oder von dazu autorisiertem Personal ausgewechselt werden.

**NL** Mocht de externe flexibele slang beschadigd worden, dan moet deze worden vervangen door de fabrikant of door een bevoegde installateur, zodat eventueel gevaar vermeden wordt.

**E** En caso de daños el cable flexible externo debe substituirse por el fabricante, su servicio de asistencia o personal calificado equivalente para evitar peligros.

**DK** Hvis den yderste ledning beskadiges, skal den udskiftes af producenten eller er et autoriseret teknisk servicecenter, eller af kvalificerede fagfolk, så man undgår farlige situationer.

**N** Hvis ytre fleksible kabel skulle bli skadet, skal denne skiftes ut av produsenten eller tilsvarende servicesenter eller av en egnet og kvalifisert fagperson for å unngå farerisiko.

**S** Om den yttre kabeln skadas ska den bytas ut av tillverkaren, av dess auktoriserade verkstad eller av likvärdigt kvalificerad personal för att undvika alla typer av risker.

**RUS** В случае повреждения внешнего гибкого кабеля во избежание риска поручите его замену производителю, уполномоченному сервису или квалифицированному электрику.

**CN** 如果外部软缆损坏，须由生产商、对应服务中心或能胜任和资深的员工更换新的电缆，以避免任何可能的危险。

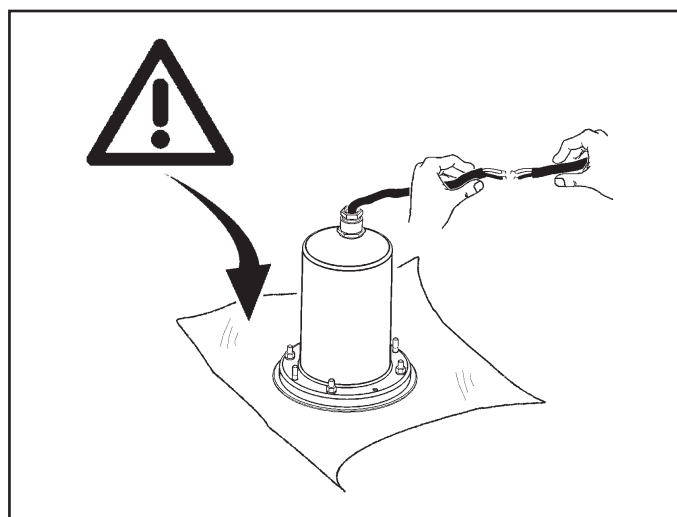

# WALL WASHER WALL WASHER SUPER COMFORT

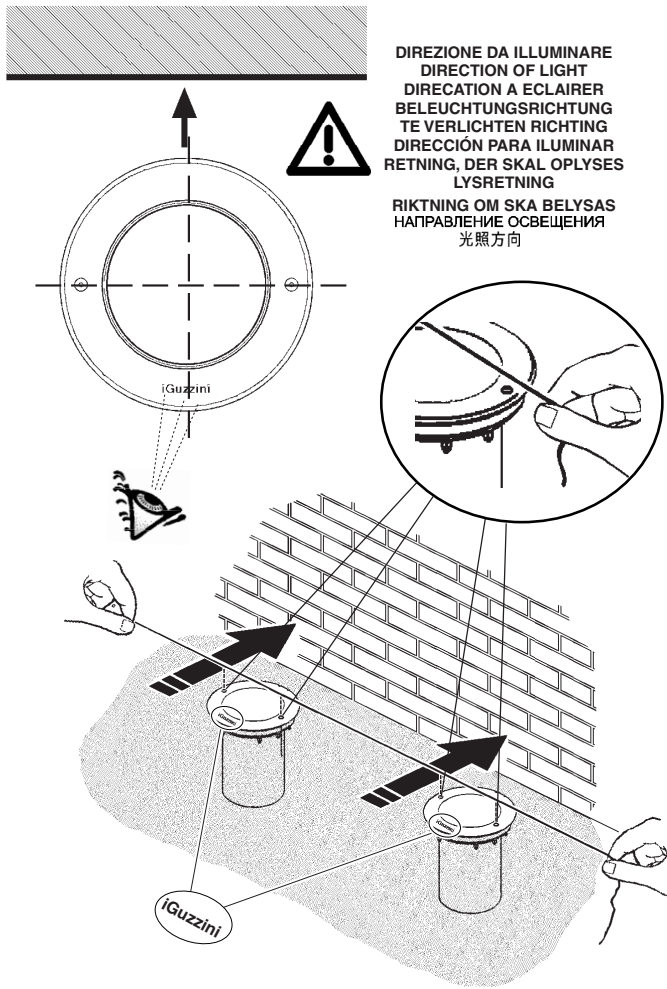

DIREZIONE DA ILLUMINARE  
DIRECTION OF LIGHT  
DIRECCION A ECLAIRER  
BELEUCHTUNGSRICHTUNG  
TE VERLICHTEN RICHTING  
DIRECCIÓN PARA ILUMINAR  
RETNING, DER SKAL OPLYSES  
LYSRETNING  
RIKTNING OM SKA BELYSAS  
НАПРАВЛЕНИЕ ОСВЕЩЕНИЯ  
光照方向

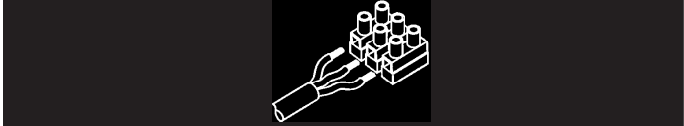
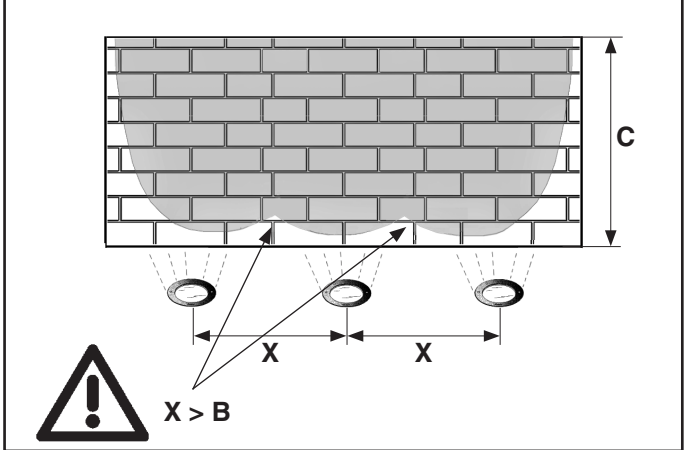
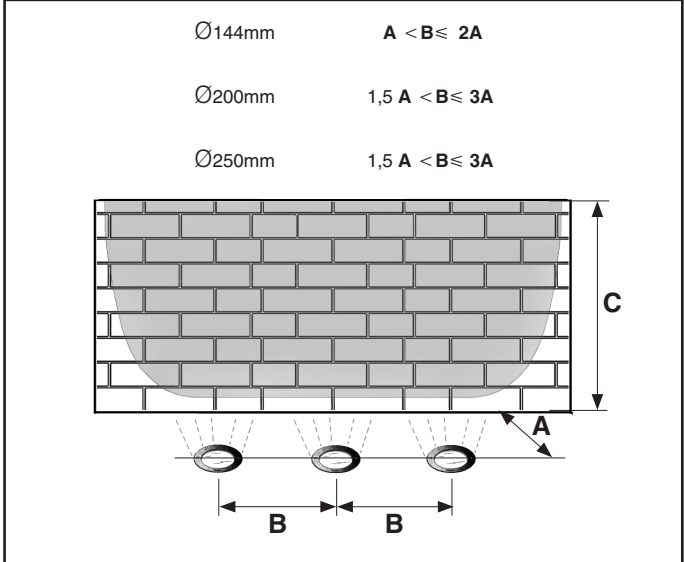

220/240 V

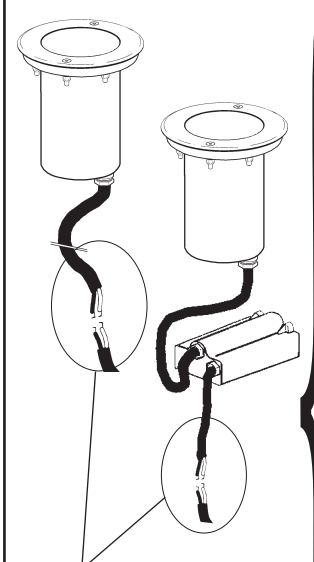

NASTRO AUTOAGGLERANTE  
SELF-VULCANISING TAPE  
RUBAN AUTO-SOUDABLE  
SELBSTHAFTBAND - (Klebefilm  
SCOTCH 23 3M)  
ZELFFUSERENDE TAPE  
CINTA AUTOAGGLERANTE  
(SCOTCH 23 3M)  
SELVKLÆBENDE BÅND  
SELVVULKANISERENDE TAPE  
SJÄLVBINDANDE BAND  
САМОПЛАСТИФИЦИРУЮЩАЯ  
ЛЕНТА  
自硫化帶

art. 9581

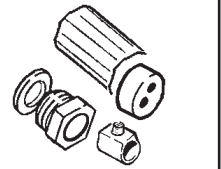

art. B915

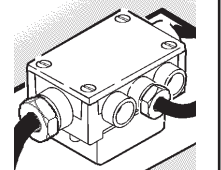

art. X188

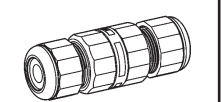

art. X189

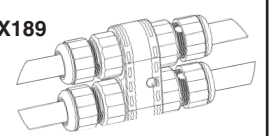

PRODUCT SIZE		A (m)	B (m)	C (m)
Ø144mm	WW super comfort	1	1 A	3 A
Ø144mm	WW	1	1 A	4 A
Ø200mm	WW super comfort	1	1,5 A	4 A
Ø200mm	WW	1	1,5 A	5 A
Ø250mm	WW super comfort	1	1,5 A	5 A
Ø250mm	WW	1	1,5 A	6 A



220/240 V

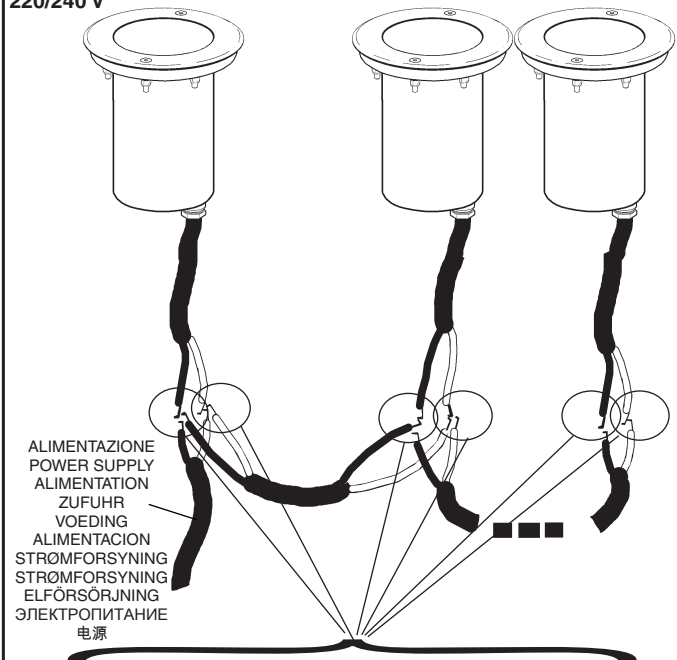

NASTRO AUTOAGGLERANTE  
 SELF-VULCANISING TAPE  
 RUBAN AUTO-SOUDABLE  
 SELBSTHAFTBAND - (Klebefilm SCOTCH 23 3M)  
 ZELFFUSERENDE TAPE  
 CINTA AUTOAGGLERANTE (SCOTCH 23 3M)  
 SELVKLÆBENDE BÅND  
 SELVVULKANISERENDE TAPE  
 SJÄLVBINDANDE BAND  
 САМОПЛАСТИФИЦИРУЮЩАЯ ЛЕНТА  
 自硫化帶

art. 9581



art. B915

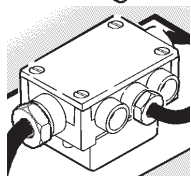

art. X189

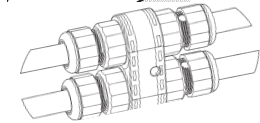

NASTRO AUTOAGGLERANTE  
 SELF-VULCANISING TAPE  
 RUBAN AUTO-SOUDABLE  
 SELBSTHAFTBAND - (Klebefilm SCOTCH 23 3M)  
 ZELFFUSERENDE TAPE  
 CINTA AUTOAGGLERANTE (SCOTCH 23 3M)  
 SELVKLÆBENDE BÅND  
 SELVVULKANISERENDE TAPE  
 SJÄLVBINDANDE BAND  
 САМОПЛАСТИФИЦИРУЮЩАЯ ЛЕНТА  
 自硫化帶

NASTRO AUTOAGGLERANTE  
 SELF-VULCANISING TAPE  
 RUBAN AUTO-SOUDABLE  
 SELBSTHAFTBAND - (Klebefilm SCOTCH 23 3M)  
 ZELFFUSERENDE TAPE  
 CINTA AUTOAGGLERANTE (SCOTCH 23 3M)  
 SELVKLÆBENDE BÅND  
 SELVVULKANISERENDE TAPE  
 SJÄLVBINDANDE BAND  
 САМОПЛАСТИФИЦИРУЮЩАЯ ЛЕНТА  
 自硫化帶

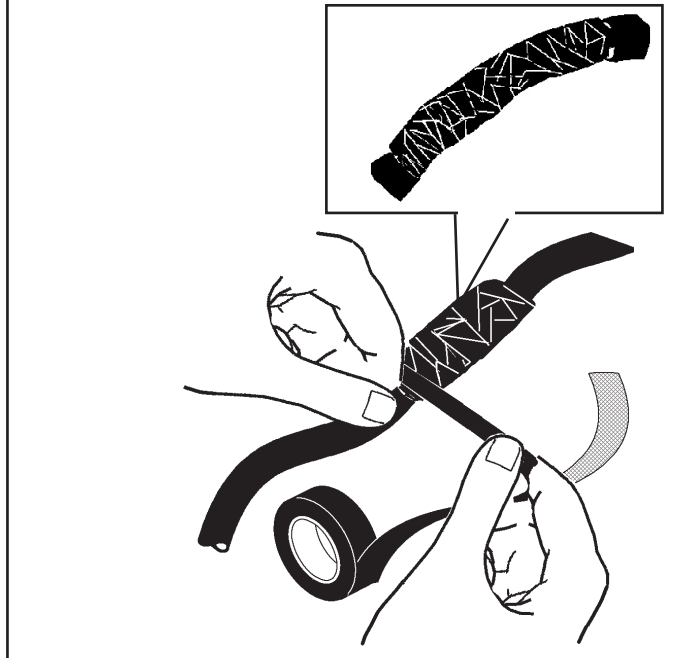
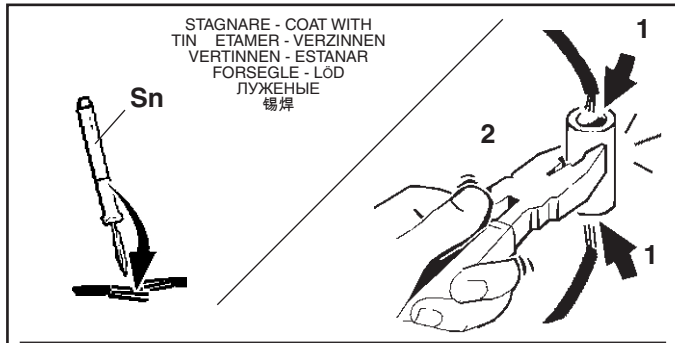
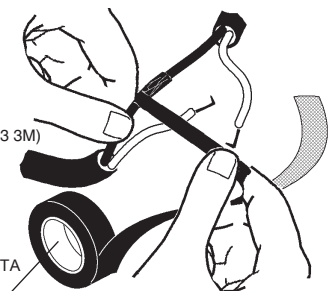

art. 9581

art. 9581

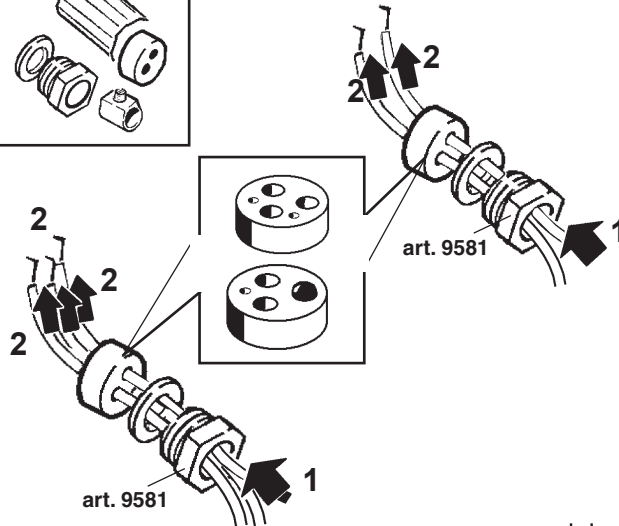
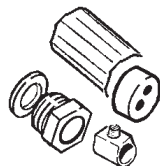

art. 9581

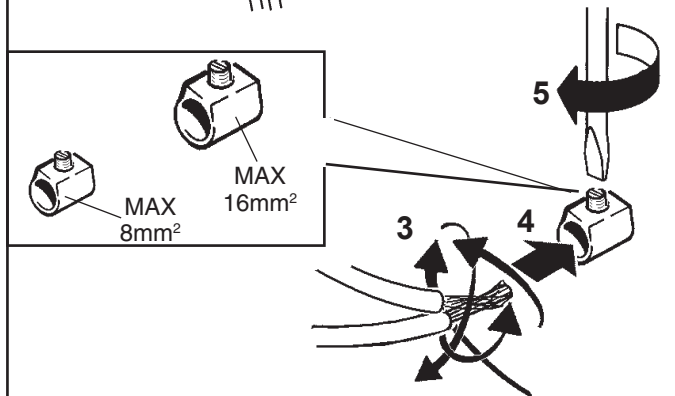
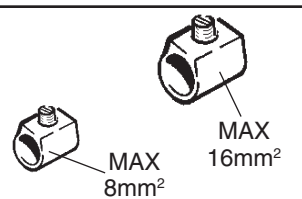

MAX 8mm<sup>2</sup>      MAX 16mm<sup>2</sup>

3      4      5

I N.B.: Verificare manualmente la tenuta dei cavi nel morsetto.  
 GB N.B.: Manually check the tightness of the cables in the terminal board.  
 F N.B.: Veuillez vérifier manuellement la tenue des fils dans la borne.  
 D NB: Der Halt der Drähte in der Klemme ist von Hand zu prüfen.  
 NL N.B.: Verifieer handmatig of de kabels goed in de klemmenstrook vastzitten.  
 E N.B.: Verificar manualmente la fijación de los cables en el terminal.  
 DK N.B.: Kontrollér, at ledningerne i klemmen sidder ordentligt fast.  
 N N.B.: Kontrollér tettheten til kablene i terminalkortet manuelt.  
 S OBS! Kontrollera för hand att kablarna sitter ordentligt fast i klämman.  
 RUS ПРИМЕЧАНИЕ: Проверьте вручную прочность соединения проводов к клеммам.  
 CN 注意: 手动检查接线排电缆的牢固性。

1      2

NASTRO AUTOAGGLOMERANTE  
 SELF-VULCANISING TAPE  
 RUBAN AUTO-SOUDABLE  
 SELBSTHAFTBAND - (Klebefilm SCOTCH 23 3M)  
 ZELFFUSERENDE TAPE  
 CINTA AUTOAGGLOMERANTE  
 (SCOTCH 23 3M)  
 SELVKLÆBENDE BÅND  
 SELVVULKANISERENDE TAPE  
 SJÄLVBINDANDE BAND  
 САМОПЛАСТИФИЦИРУЮЩАЯСЯ ЛЕНТА  
 自硫化帶

5

art. B915

IN      OUT

POZZETTO DI DERIVAZIONE  
 BRANCH POINT  
 TRAPPE POUR BOÎTE DE DÉRIVATION  
 ABZWEIGSCHACHT  
 CONTACTPUTJE  
 CAJA DE DERIVACIÓN  
 TILSLUTNINGSDÅSE  
 GRENPUNKT  
 KOPPLINGSBRUNN  
 УЗЛОВАЯ ТОЧКА  
 分支点

art. B915

1      2      3

D (mm)	Ø (mm)
8,0 ÷ 10,0	8,5
10,0 ÷ 12,5	11
12,5 ÷ 14,5	13,5
14,5 ÷ 16,0	15,5

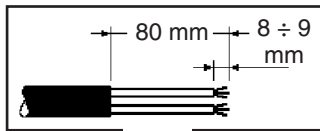
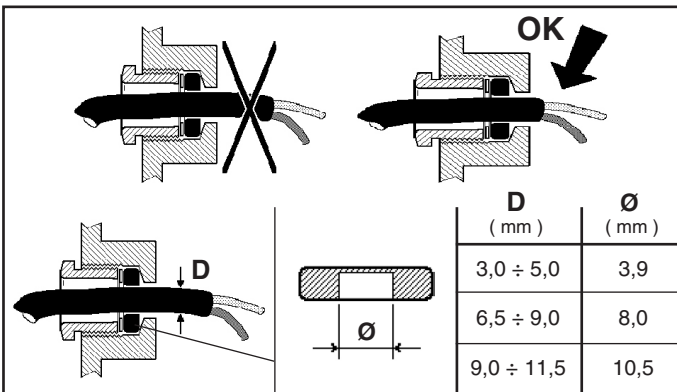

MIN 0,75mm<sup>2</sup>  
MAX 2,5 mm<sup>2</sup>

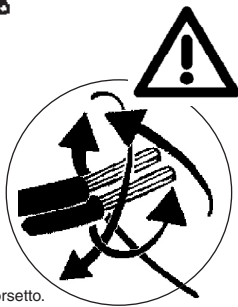
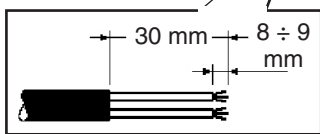
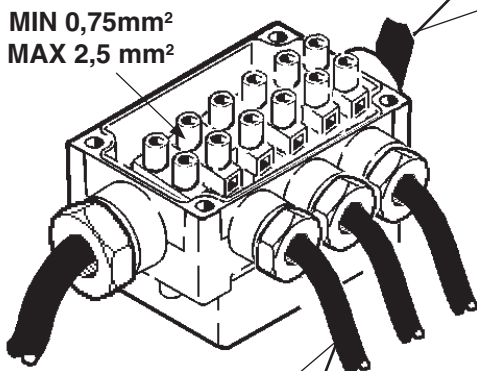

- I N.B.: Verificare manualmente la tenuta dei cavi nel morsetto.
- GB N.B.: Manually check the tightness of the cables in the terminal board.
- F N.B.: Veuillez vérifier manuellement la tenue des fils dans la borne.
- D NB: Der Halt der Drähte in der Klemme ist von Hand zu prüfen.
- NL N.B.: Verifieer handmatig of de kabels goed in de klemmenstrook vastzitten.
- E N.B.: Verificar manualmente la fijación de los cables en el terminal.
- DK N.B.: Kontrollér, at ledningerne i klemmen sidder ordentligt fast.
- N N.B.: Kontrollér tettheten til kablene i terminalkortet manuelt.
- S OBS! Kontrollera för hand att kablar sitter ordentligt fast i klämman.
- RUS ПРИМЕЧАНИЕ: Проверьте вручную прочность соединения проводов к клеммам.
- CN 注意: 手动检查接线排电缆的牢固性。

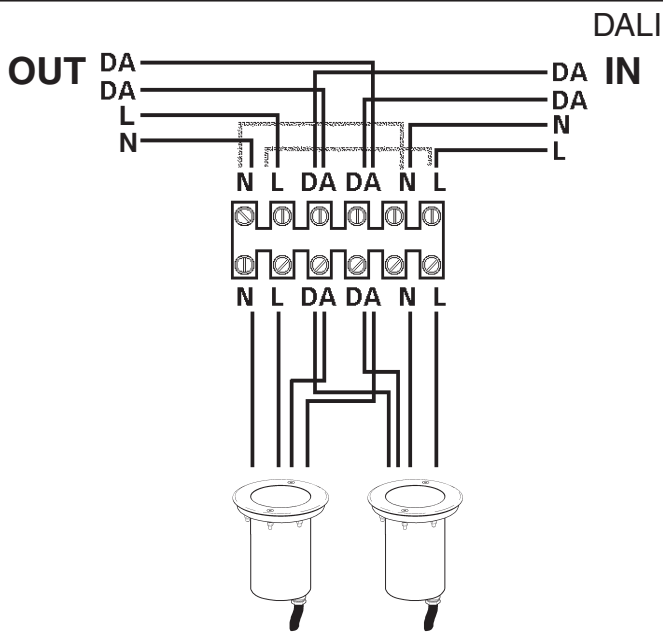
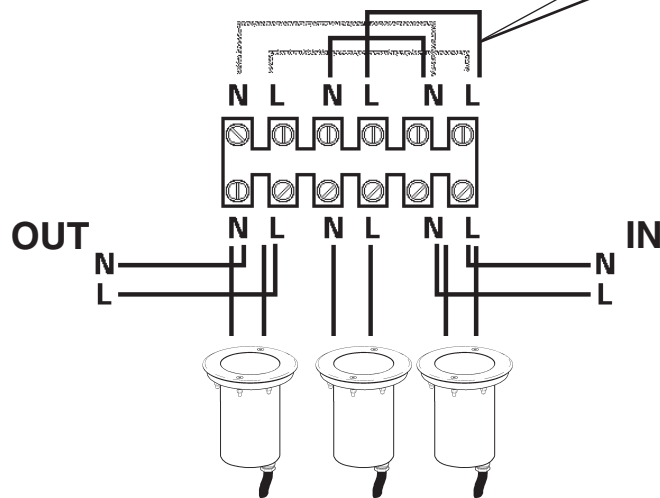
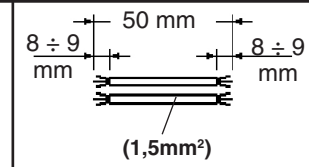
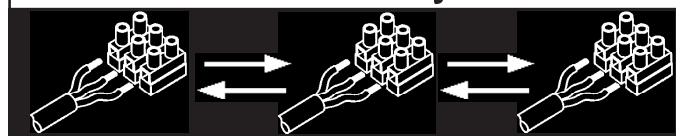
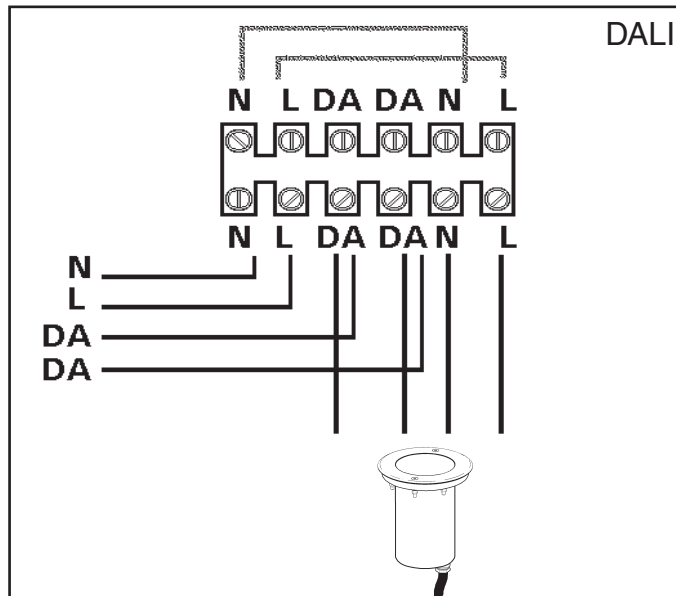
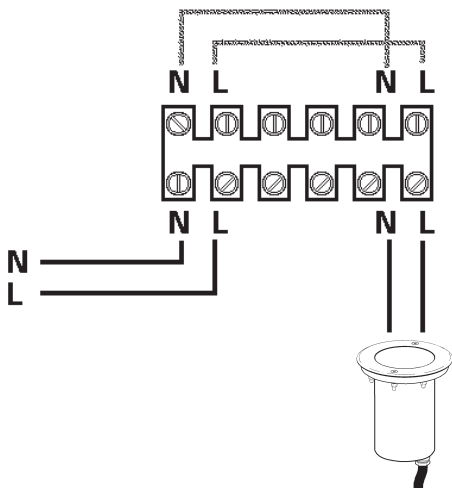
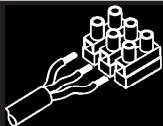

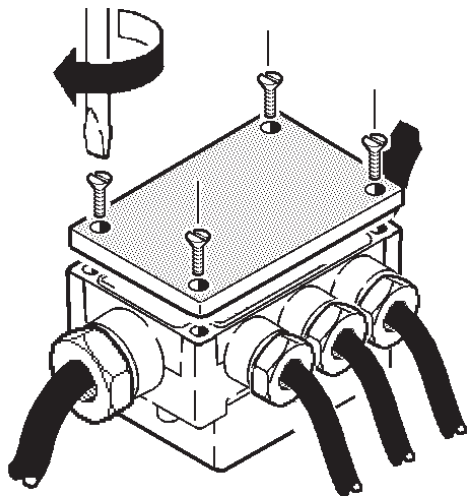

art. X188

art. X188

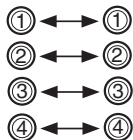
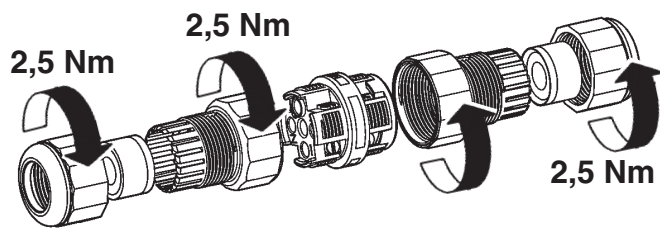
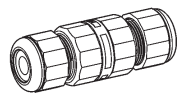

MAX 4 mm<sup>2</sup>

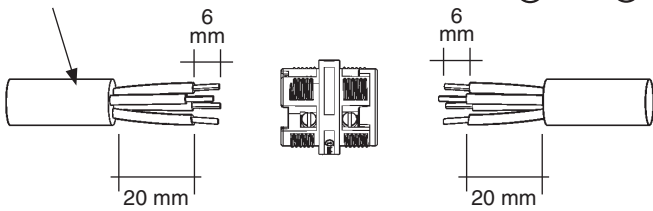

D ( mm )	
4,5 ÷ 7 mm	
7 ÷ 9 mm	
9 ÷ 12 mm	

art. X189

art. X189

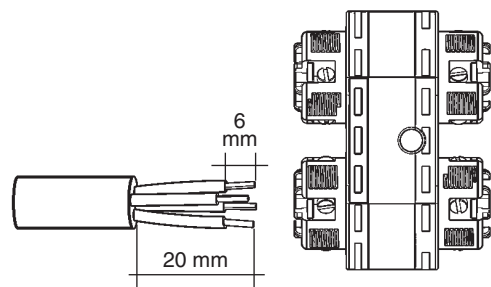
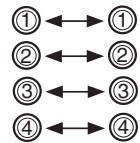
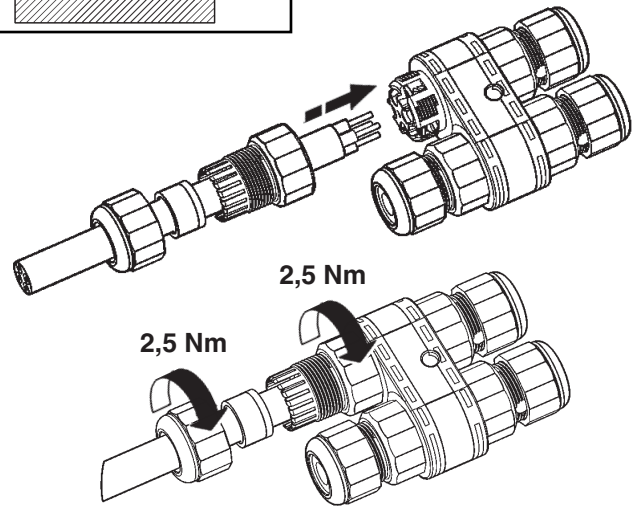
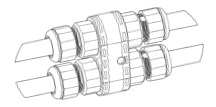
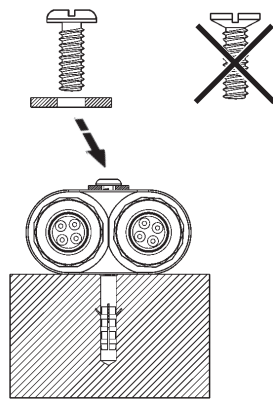

D ( mm )	
4,5 ÷ 7 mm	
7 ÷ 9 mm	
9 ÷ 12 mm	

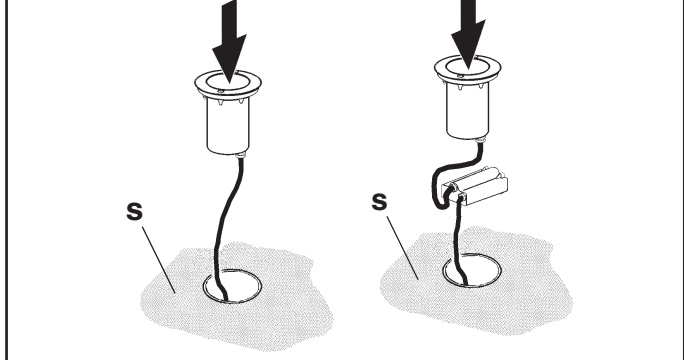
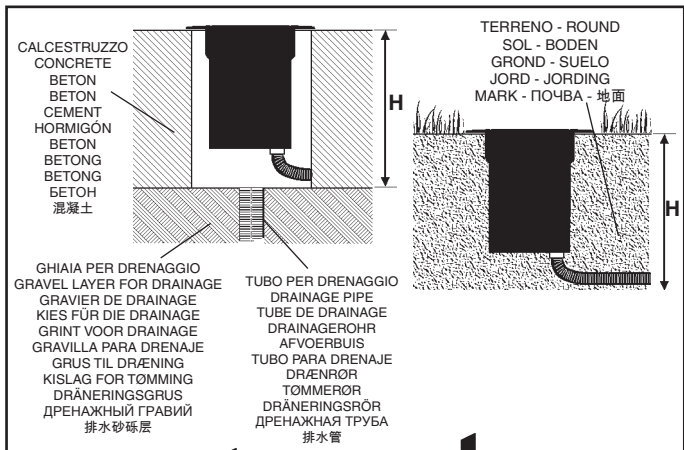

	H	
	NO DALI	DALI
Ø 144mm	200mm	240mm
Ø 200mm	/	210mm
Ø 250mm	/	230mm 280mm

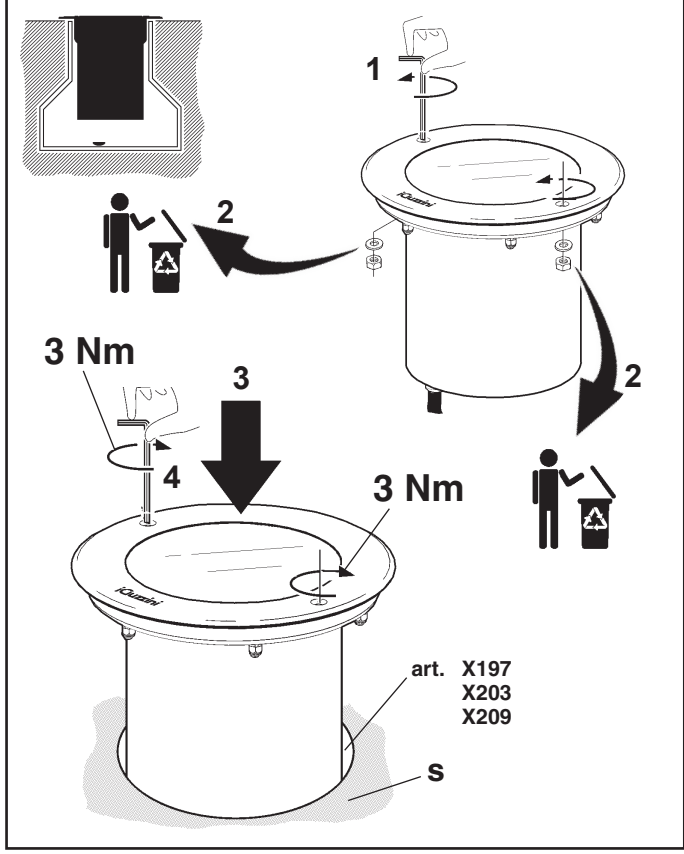

I Accertarsi che l'area "S" sulla quale poggierà la cornice non presenti sporgenze.  
**GB** Make sure area "S" onto which the frame will rest is free of any projections.  
**F** Contrôlez que la zone «S» sur laquelle reposera le cadre ne présente pas d'aspérités.  
**D** Vergewissern Sie sich, dass der Bereich „S“, also die Stelle, wo der Rahmen aufgelegt wird, keine Unebenheiten aufweist.  
**NL** Let op dat de zone "S" waarop de lijst zal rusten geen uitsteeksels vertoont.  
**E** Asegurarse de que el área «S», sobre la que se apoyará el marco, no presente salientes.  
**DK** Kontrollér, at området "S", som kanten støtter mod, ikke rager ud nogen steder.  
**N** Se til at området "S" der rammen skal hvile er fri for fremspring.  
**S** Försäkra dig om att det inte finns några utstickande delar på området "S" där ramen vilar.  
**RUS** Проверьте, чтобы площадь "S", на которую опирается рамка, не имела выступов.  
**CN** 确保框架放置的"S"区域无任何照射。

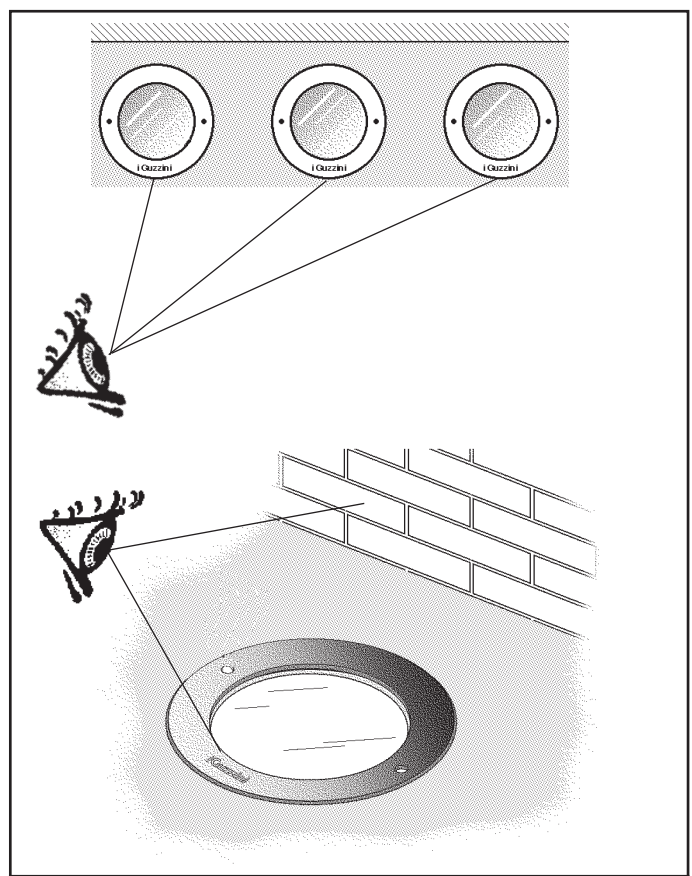

I Disporre i cavi ai lati dell'apparecchio come indicato in figura.  
**GB** Arrange the cables on the sides of the luminaire as indicated in the figure.  
**F** Placez les câbles sur les côtés de l'appareil comme illustré (voir figure).  
**D** Ordnen Sie die Kabel wie in der Abbildung dargestellt an den Seiten der Leuchte an.  
**NL** Plaats de kabels aan de zijkanten van het apparaat zoals aangegeven in de afbeelding.  
**E** Coloque los cables a los costados del aparato como lo indica la figura.  
**DK** Anbring ledningerne på siderne af armaturet, som vist i figuren.  
**N** Plasser kablene på siden av lysarmaturen slik som indikert på figuren.  
**S** Placera kablarna på utrustningens sidor, som visas i figuren.  
**RUS** Расположите провода по бокам прибора, как показано на схеме.  
**CN** 如图所示在灯具侧排列电缆。

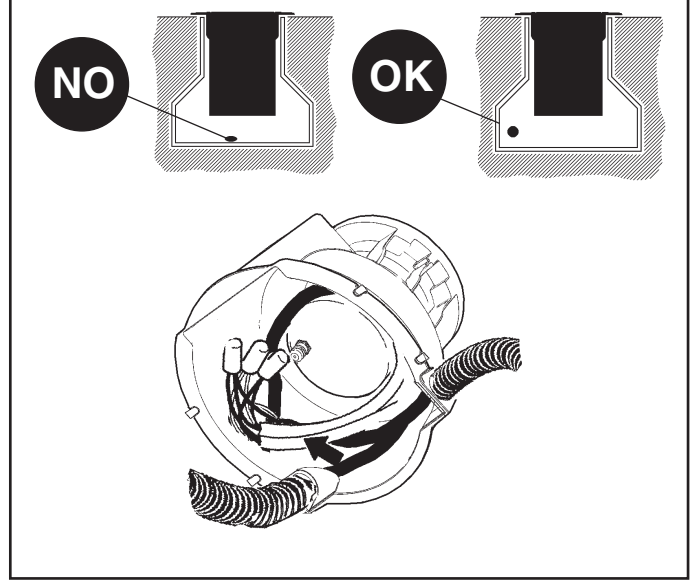



## DALI

CARICO DALI / DALI LOAD  
CHARGE DALI  
(COURANT MAXI ADMISSIBLE)  
DALI-LAST  
DALI VERMOGEN  
CARGA DALI  
DALI STRÖMSTYRKE  
BELASTNING FOR "DALI"  
DALI-BELASTNING  
МАКС. ТОК СИСТЕМЫ DALI С  
РЕГУЛЯЦИЕЙ ИНТЕНСИВНОСТИ  
СВЕТА  
DALI 智能调光系统允许的最大电流量

INDIRIZZI DALI  
DALI ADDRESSES  
ADRESSES DALI  
DALI-ADRESSEN  
DALI-ADRESSEN  
DIRECCIONES DALI  
DALI ADRESSER  
ADRESSER TIL "DALI"  
DALI-ADRESSER  
ЛОГИЧЕСКИЕ АДРЕСА  
СИСТЕМЫ DALI  
DALI 智能调光系统计算机指定控制参数

1 (2 m A)

1

## art. B916

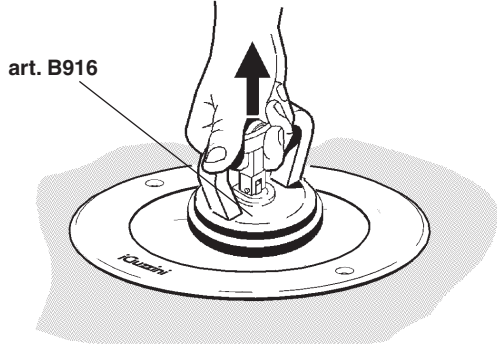

I N.B.: Per la sostituzione del LED contattare l'azienda iGuzzini.

GB N.B.: For information on LED replacement please contact iGuzzini.

F N.B.: Pour procéder au remplacement de la LED, adressez-vous à la société iGuzzini.

D Ñ.B.: Bezüglich des Austausches der LED kontaktieren Sie bitte die Firma iGuzzini.

NL N.B.: Voor het vervangen van de LED neemt u contact op met het bedrijf iGuzzini.

E NOTA: Para sustituir el LED llame a la empresa iGuzzini.

DK N.B.: For udskiftning af lysdioden, skal man kontakte iGuzzini.

N N.B.: For informasjon om skifte av LED, vennligst ta kontakt med iGuzzini.

S OBS! För byte av lysdioden, kontakta företaget iGuzzini.

RUS ПРИМЕЧАНИЕ: Для замены СИДов обращайтесь в компанию iGuzzini.

CN 注意：如需LED更换的信息，请联系iGuzzini。

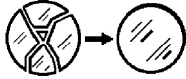

I In caso di rottura del vetro il prodotto non può essere utilizzato, contattare il costruttore per la sua sostituzione.

GB Should the glass break, the product cannot be used and you should contact the manufacturer for its replacement.

F En cas d'endommagement de l'écran de protection le produit ne peut pas être utilisé, contactez le fabricant pour le remplacement.

D Falls das Glas kaputt sein sollte, kann das Produkt nicht verwendet werden. Kontaktieren Sie in dem Fall den Hersteller, um das Glas zu ersetzen.

NL Als het glas gebroken is kan het apparaat niet worden gebruikt en moet u zich tot de fabrikant wenden voor het vervangen van het glas.

E No utilizar el producto en caso de ruptura del vidrio y contactar el fabricante para la sustitución.

DK Hvis produktets glas ødelægges, kan det ikke anvendes. Kontakt forhandleren med henblik på udskiftning.

N Hvis glasset skulle knuses, kan ikke produktet brukes, og du må ta kontakt med produsenten for å få det skiftet.

S Om glaset går sönder kan inte produkten användas. Kontakta tillverkaren för att byta ut glaset.

RUS В случае разбивания стекла не используйте прибор, обратитесь к его производителю для замены.

CN 旦玻璃破碎后产品将不能再使用，须联系生产商予以更换。

## + ART

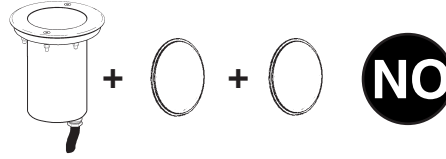
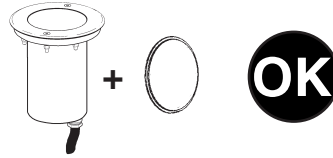

	ART.			
Ø 144mm	E112 - E113 - E114 E116 - E117 - E118 BW00 - BW01 - BW02 BW03 - BW04 - BW05	X199	X200	X198
Ø 200mm	E129 - E130 - E131 E134 - E135 - E136	X205	X206	X204
Ø 200mm	E127 - E128 - E132 E133	X240	X241	X242
Ø 250mm	E149 - E150 - E151 E152 - E153 - E154 E155 - E156 - E157 E158 - E163 - E164 E165 - E166 - E167 E168 - E111 - E112 E113 - E114 - E115 E116	X202	X207	X201



I Attenzione, rischio di scossa elettrica

GB Caution, risk of electric shock

F Attention, risque de choc électrique

D Achtung, Stromschlaggefahr

NL Let op, gevaar voor elektrische schok

E Atención: riesgo de descarga eléctrica

DK Advarsel: Fare for elektrisk stød

N Forsiktig! Fare for elektrisk stød

S Observera, risk för elstöt

RUS Внимание, риск поражения электрическим током

CN 小心，触电危险





**2,5 Nm**  
Serrare a fondo  
Tighten firmly  
Serrer à fond  
Fest einrasten  
Goed aanschroeven  
Enrosar en firme  
Skrues i bund  
Trek til godt  
Dra åt till botten  
закручивать до упора  
完全拧紧

- I Assicurarsi che la guarnizione "B" sia posizionata come in figura.  
**GB** Make sure that the seal "B" is positioned as shown in the figure.  
**F** Contrôlez que le joint "B" est bien monté comme illustré par la figure.  
**D** Achten Sie darauf, daß die Dichtung "B" so wie in der Abbildung veranschaulicht aufgelegt wird.  
**NL** Let erop dat de afdichting "B" geplaatst wordt zoals in de afbeelding.  
**E** Comprobar que la junta "B" resulte en la posición indicada en figura.  
**DK** Kontrollér, at pakningen "B" sidder, som vist i figuren.  
**N** Se til at forsejlingen "B" er posisjonert slik som vist på figuren.  
**S** Försäkra dig om att pakningen "B" sitter korrekt som i figuren.  
**RUS** Проверьте, чтобы уплотнение «B» было установлено, как показано на схеме.  
**CN** 确认封条"B"如图所示放置。

- I N.B.: I dadi che fissano la cornice al corpo debbono essere serrati a fondo in modo uniforme, passando alternativamente da un dado a quello diametralmente opposto. Per facilitare l'estrazione del vetro senza danneggiare la guarnizione a cornice montata, svitare tutti i dadi ad esclusione di due consecutivi ed attendere; svitare poi i restanti dadi e togliere il vetro.
- GB** N.B.: The nuts securing the frame to the body must be fully tightened in a uniform manner, alternating between diametrically opposed nuts. To facilitate the extraction of the glass without damaging the gasket fitted onto the frame, unscrew all the nuts except for two adjacent ones and wait; then unscrew the remaining nuts and remove the glass.
- F** N.B.: Les boulons qui fixent le cadre au corps doivent être serrés à fond et de façon uniforme en passant alternativement d'un boulon à un autre diamétralement opposé. Pour simplifier l'extraction du verre sans endommager le joint quand le cadre est monté, dévisser tous les écrous sauf deux consécutifs, attendre puis dévisser les autres écrous et déposer le verre.
- D** N.B.: Die Muttern, mit Hilfe derer der Rahmen am Leuchtenkörper befestigt wird, müssen gleichmäßig fest angezogen werden, wobei nach dem Anziehen einer Mutter immer die diametral gegenüberliegende Mutter anzuziehen ist. Um das Herausnehmen des Glases zu erleichtern und ein Beschädigen der Dichtung bei montiertem Rahmen zu verhindern, drehen Sie alle bis auf zwei benachbarte Schraubenmuttern heraus und warten Sie einen Moment. Drehen Sie dann die restlichen Muttern heraus und entfernen Sie das Glas.
- NL** N.B.: De moeren die de lijst aan de romp bevestigen moeten gelijkmatig compleet worden aangeschroefd, afwisselend van de ene moer naar de andere die er lijnrecht tegenover ligt. Voor het gemakkelijker verwijderen van de glasplaat zonder de afdichting te beschadigen, als de lijst reeds is gemonteerd, schroeft u alle moeren los behalve twee achter elkaar en wacht u een paar seconden. Daarna schroeft u de resterende moeren los en verwijdert u de glasplaat.
- E** N.B.: Los pernos que fijan el marco al cuerpo se deben apretar a fondo de modo uniforme, pasando alternativamente de un perno a otro diametralmente opuesto. Una vez colocado el marco, para facilitar la extracción del vidrio sin dañar la junta, desenroscar todas las tuercas que no sean consecutivas y esperara algunos segundos, desenroscar luego las tuercas restantes y quitar el vidrio.
- DK** N.B.: Møtrikkerne, der fastgør rammen til legemet, skal skrues i bund på en ensartet måde, idet de strammes i diagonal rækkefølge. For at gøre udtrækning af glasset nemmere, uden at ødelægge pakningen på rammen, skal man løse alle møtrikker på nær to tilstødende møtrikker og vente lidt og så løse resten af møtrikkerne og tage glasset ud.
- N** N.B.: Mutrene som sikrer rammen til huset må være fullstendig tiltrukket på en jevn måte, ved å skifte mellom diametrisk motstående bolter. For å forenkle uttrekkingen av glasset uten å skade pakningen som sitter på rammen, skal alle mutrene, unntatt de to tilgrensende, skrues løs. Vent, og skru deretter løs de resterende mutrene og fjern glasset.
- S** OBS! Muttrarna som fäster ramen vid kroppen ska dras åt till botten på ett jämnt sätt genom att korsdras. För att underlätta utdragningen av glasset utan att skada pakningen på den monterade ramen, skruva ur alla muttrar förutom de två som sitter i följd och vänta. Skruva sedan ur de sista muttrarna och ta bort glasset.
- RUS** ПРИМЕЧАНИЕ: Гайки, соединяющие рамку с корпусом, должны быть равномерно затянуты до упора, переходя от одной гайки к прямо противоположной (крест на крест). Для облегчения операции по съёму стекла без риска повредить уплотнение с уже установленной рамкой, отвинтите все гайки за исключением двух последовательных и подождите несколько секунд, затем отвинтите остальные гайки и выньте стекло.
- CN** 注意事项：用来固定主体框架的螺钉应该均匀地拧紧至深处。为了方便地取出玻璃，但是又不损坏已经安装好的框架垫圈，小心谨慎拧开所有的螺钉，卸下玻璃。

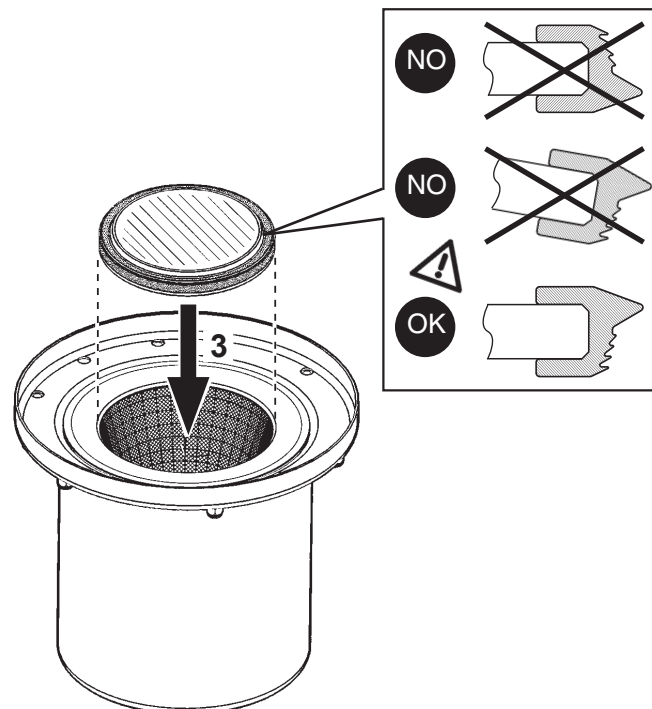

## LIGHT UP EARTH



تَحذِير :

لا يمكن ضمان سلامة هذا الجهاز إلا إذا التزمت بهذه التعليمات. يجب حفظها في مكان آمن.

### ATTENZIONE:

LA SICUREZZA DELL'APPARECCHIO E' GARANTITA SOLO CON L'USO APPROPRIATO DELLE SEGUENTI ISTRUZIONI; PERTANTO E' NECESSARIO CONSERVARLE.

### WARNING:

THE SAFETY OF THIS FIXTURE IS GUARANTEED ONLY IF YOU COMPLY WITH THESE INSTRUCTIONS; REMEMBER TO CONSERVE IN A SAFE PLACE.

### ATENCIÓN:

LA SEGURIDAD DEL APARATO SE GARANTIZA SOLO CUMPLIENDO CUIDADOSAMENTE LAS SIGUIENTES INSTRUCCIONES; POR ELLO, ES NECESARIO CONSERVARLAS.

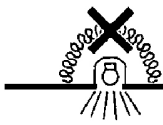
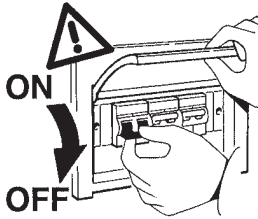

ملاحظة: أجهزة غير قابلة للتغطية مواد عازلة حرارياً.

I N.B.: Apparecchi non idonei ad essere coperti di materiale termicamente isolante

GB N.B.: Fixtures not suitable to be covered in thermally-insulating material.

E OBS! Utrustningen får inte täckas över med värmeisolerande material

ملاحظة: ملاحظة: أثناء تركيب نظام . يجب التقيد بحرص بالنظم السائدة المتعلفة بالشبكة الكهربائية.

N.B.: DURANTE L'INSTALLAZIONE DEL SISTEMA RISPETTARE SCRUPolosAMENTE LE NORME IMPIANTISTICHE VIGENTI.

N.B.: WHEN INSTALLING THE SYSTEM STRICTLY COMPLY WITH ALL REGULATIONS ON INSTALLATION IN FORCE.

N.B.: DURANTE LA INSTALACIÓN DEL SISTEMA RESPETAR ESCRUPolosAMENTE LAS NORMAS DE INSTALACIÓN VIGENTES.



تم تصميم الأجهزة واختبارها لكي تكون قادرة على تحمل حمولة استاتيكية تصل إلى غاية 50000 كغم وبنفس الوقت مقاومة للتأثيرات الناتجة عن عملية التشغيل. التركيب غير مسموح في المناطق التي تمر فيها جرافات الثلج وبسرعة تزيد عن 50 كغم/ساعة.

I Gli apparecchi sono stati progettati e collaudati per reggere un carico statico fino a 50000 N e resistere alle sollecitazioni di percorrenza. L'installazione non è ammessa in zone di utilizzo di spalanee e con carrabilità a velocità superiori ai 50 Km/h.

GB The lighting fixtures were designed and tested to withstand a static load of up to 50000 N and to resist drive-over stress. The fixtures may not be installed in areas where snowplows are used, or where the drive-over speed exceeds 50 km/h.

E Los aparatos han sido proyectados y probados para soportar una carga estática máxima de 50000 N y resistir a los esfuerzos derivados del tránsito. La instalación no está admitida en zonas donde se utilizan máquinas para espalar la nieve y donde esté permitido el tráfico a velocidades superiores a los 50 Km/h.

تنبيه: ينصح القيام بعملية التركيب والصيانة داخل الحجرة البصرية أو في أجواء داخلية أو على الأقل في أماكن خالية من الرطوبة و المطر.

I N.B.: Si consiglia di effettuare le operazioni d'installazione o di manutenzione all'interno del vano ottico, in ambienti interni o quanto meno in assenza di umidità o pioggia.

GB N.B.: Installation and maintenance operations must be carried out inside the optical assembly, indoor and in a place with no humidity or rain.

E N.B.: Se recomienda efectuar las operaciones de instalación o mantenimiento dentro del cuerpo óptico, en interiores o por lo menos en ausencia de humedad o lluvia.

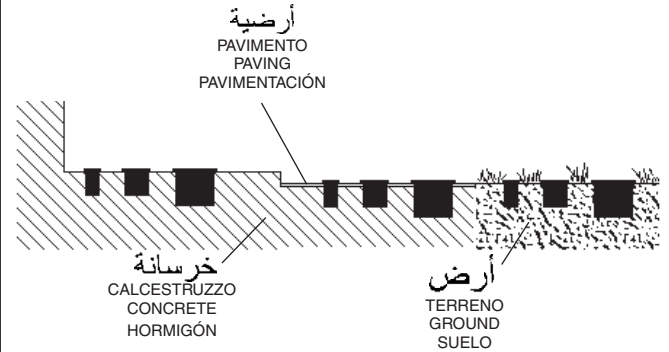

	NO DALI	DALI
Ø 144mm ملم		
Ø 200mm ملم		
Ø 250mm ملم		



يوصى بتوفير الحماية الكافية للكابل، ومنعه من الاتصال المباشر بالأرض. عر

I Si consiglia di proteggere adeguatamente il cavo dal contatto diretto con il terreno.

GB The cable should be suitably protected against direct contact with the ground.

E Se recomienda proteger adecuadamente el cable del contacto directo con el terreno.



في حال تلف الكبل الخارجي المرنة، يجب تغييره من قبل المصنع أو من قبل مركز الخدمة المخوّل أو من قبل أحد أعضاء الطاقم الملائمين والمؤهلين وذلك لتحاكي إلحاق أي خطر.

I In caso di danneggiamento del cavo flessibile esterno, questo deve essere sostituito dal costruttore, o dal suo servizio di assistenza, o da personale qualificato equivalente, al fine di evitare pericoli.

GB Should the outer flexible cable be somehow damage, the latter should be replaced by the manufacturer, or by the corresponding service centre, or by an appropriate and qualified member of staff in order to avoid all risk of danger.

E En caso de daños el cable flexible externo debe substituirse por el fabricante, su servicio de asistencia o personal calificado equivalente para evitar peligros.



PRODUCT SIZE		A P (m)	B P (m)	C P (m)
Ø144mm	WW super comfort	1	1 A	3 A
Ø144mm	WW	1	1 A	4 A
Ø200mm	WW super comfort	1	1,5 A	4 A
Ø200mm	WW	1	1,5 A	5 A
Ø250mm	WW super comfort	1	1,5 A	5 A
Ø250mm	WW	1	1,5 A	6 A

$\varnothing 144\text{mm}$        $A < B \leq 2A$   
 $\varnothing 200\text{mm}$        $1,5 A < B \leq 3A$   
 $\varnothing 250\text{mm}$        $1,5 A < B \leq 3A$

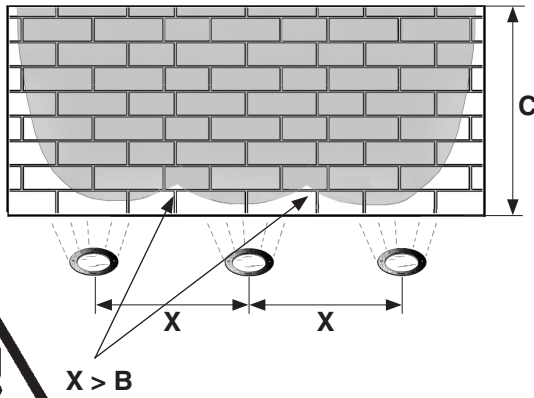
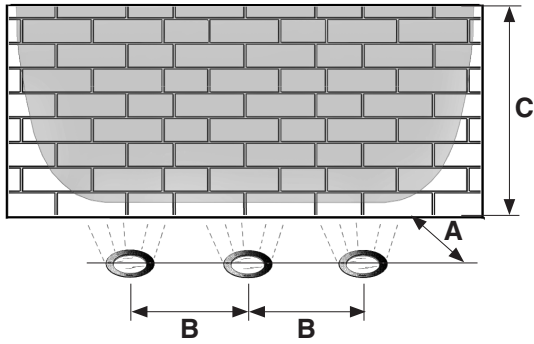

$X > B$

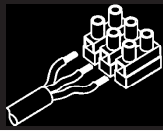

220/240 V

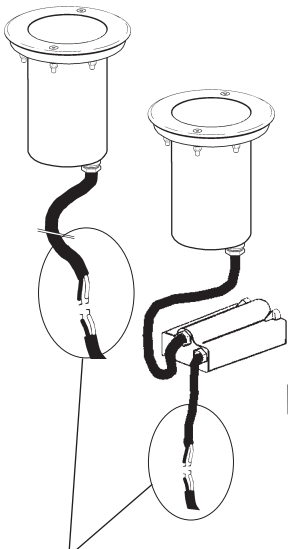

شريط يتكتل بشكل ذاتي

NASTRO AUTOAGGLOMERANTE  
SELF-VULCANISING TAPE  
CINTA AUTOAGGLOMERANTE  
(SCOTCH 23 3M)



الصف  
art. 9581

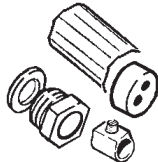

الصف  
art. B915

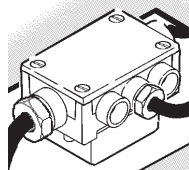

الصف  
art. X188

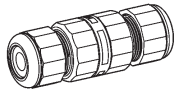

الصف  
art. X189

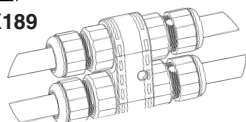

مصدر التيار  
ALIMENTAZIONE  
POWER SUPPLY  
CEBADOR

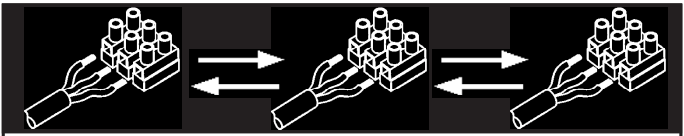

220/240 V

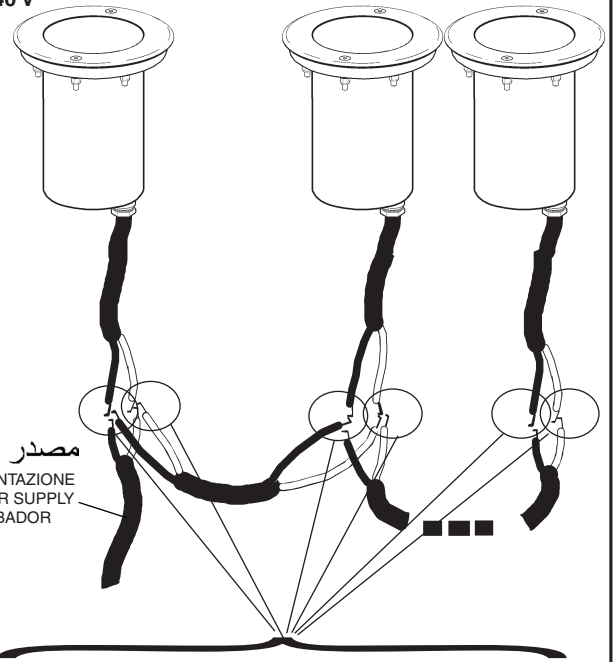

مصدر التيار  
ALIMENTAZIONE  
POWER SUPPLY  
CEBADOR

شريط يتكتل بشكل ذاتي

NASTRO AUTOAGGLOMERANTE  
SELF-VULCANISING TAPE  
CINTA AUTOAGGLOMERANTE  
(SCOTCH 23 3M)



الصف  
art. 9581

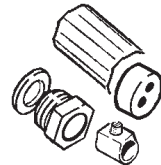

الصف  
art. B915

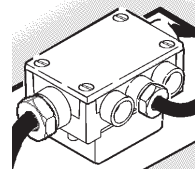

الصف  
art. X189

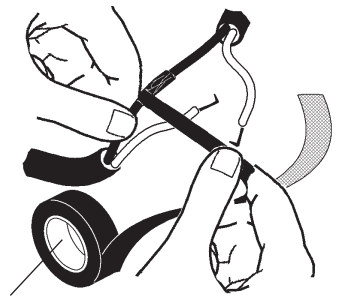
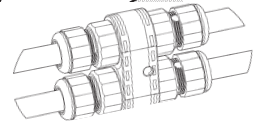

شريط يتكتل بشكل ذاتي

NASTRO AUTOAGGLOMERANTE  
SELF-VULCANISING TAPE  
CINTA AUTOAGGLOMERANTE  
(SCOTCH 23 3M)



ألحم  
STAGNARE  
WELD  
ESTANAR

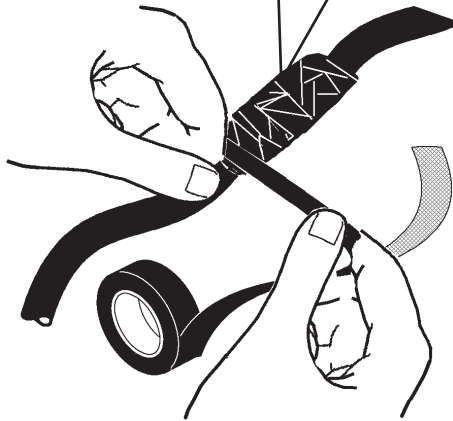
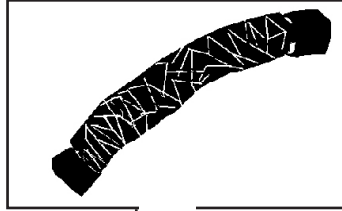
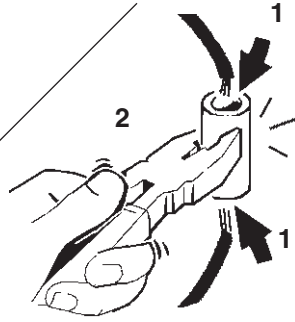

art. 9581

الصف art. 9581

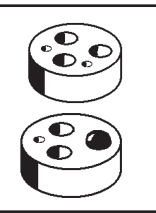
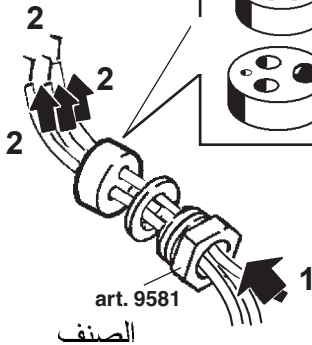
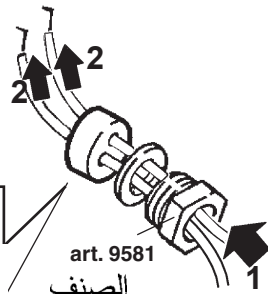
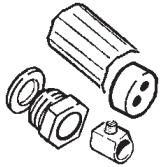

art. 9581  
الصف

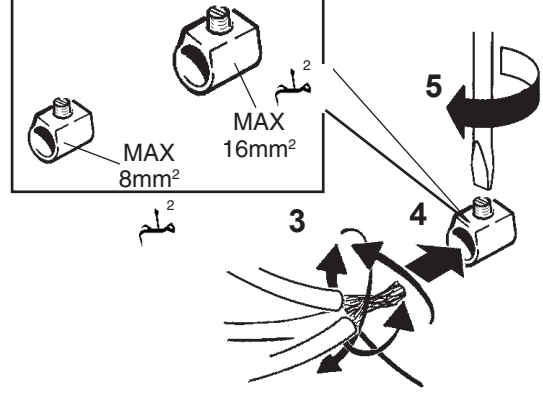
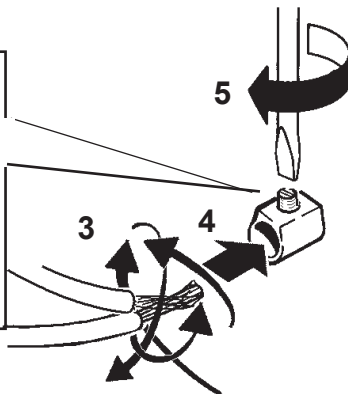
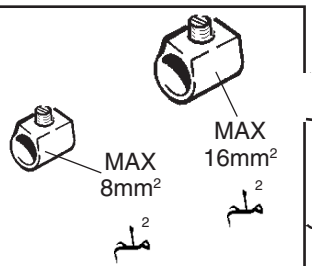

تنبيه: تحقق يدويا من مناعة الكبلات داخل طرف التوصيل.

I N.B.: Verificare manualmente la tenuta dei cavi nel morsetto.

GB N.B.: Manually check the tightness of the cables in the terminal board.

E N.B.: Verificar manualmente la fijación de los cables en el terminal.

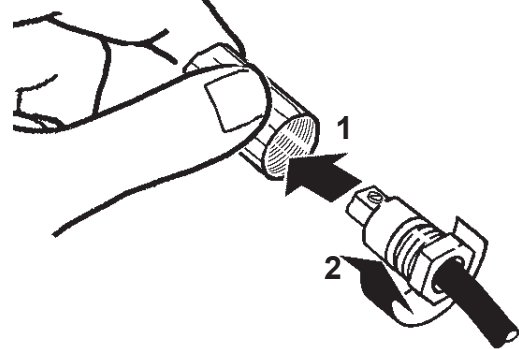

شريط يتكتل بشكل ذاتي

NASTRO AUTOAGGLOMERANTE  
SELF-VULCANISING TAPE  
CINTA AUTOAGGLOMERANTE  
(SCOTCH 23 3M)

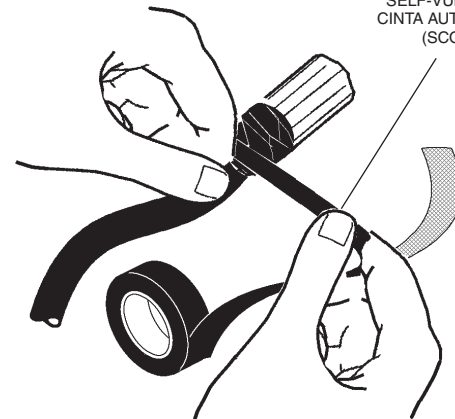

art. B915

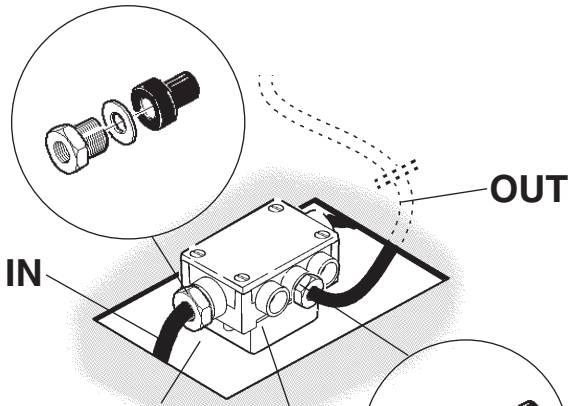

حوض التوصيل  
POZZETTO DI DERIVAZIONE  
BRANCH POINT  
CAJA DE DERIVACIÓN

art. B915  
الصف

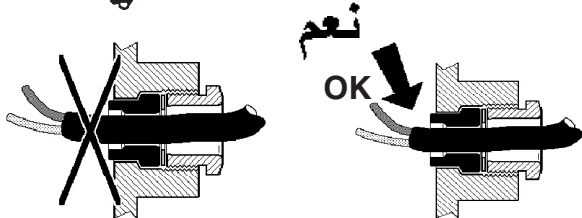
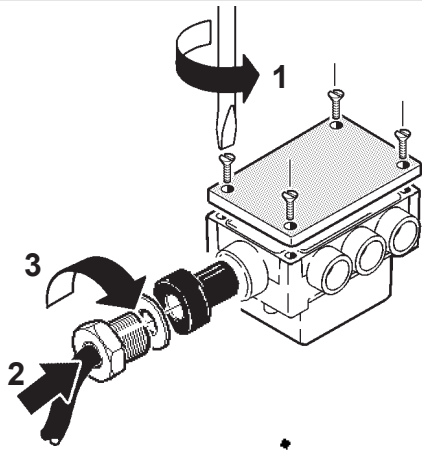

D ملم (mm)	Ø ملم (mm)
8,0 ÷ 10,0	8,5
10,0 ÷ 12,5	11
12,5 ÷ 14,5	13,5
14,5 ÷ 16,0	15,5

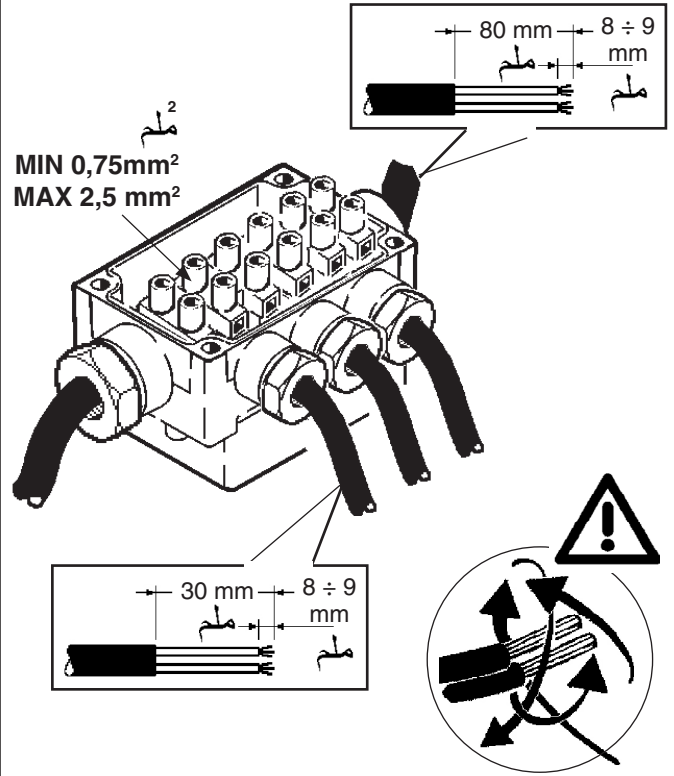
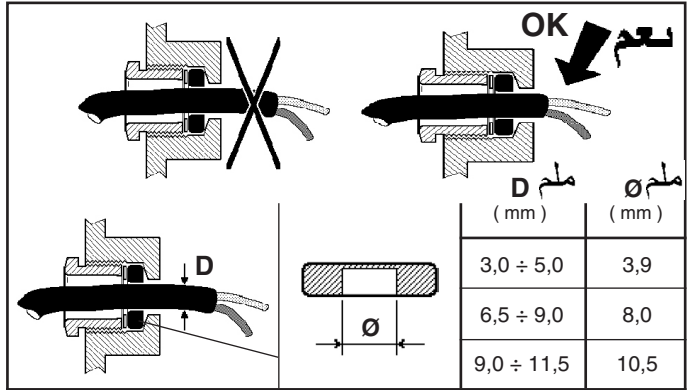
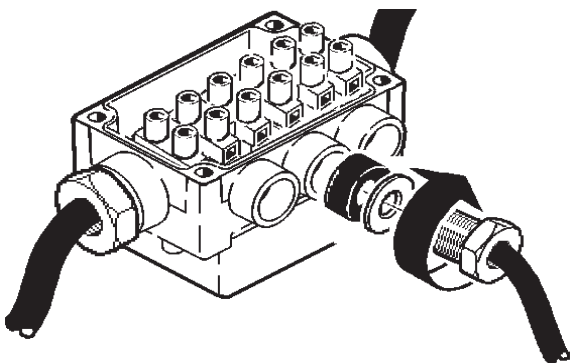

MIN 0,75mm<sup>2</sup>  
MAX 2,5 mm<sup>2</sup>

تنبيه: تحقق يدويا من مناعة الكيلاات داخل طرف التوصيل.

- I N.B.: Verificare manualmente la tenuta dei cavi nel morsetto.
- GB N.B.: Manually check the tightness of the cables in the terminal board.
- E N.B.: Verificar manualmente la fijación de los cables en el terminal.

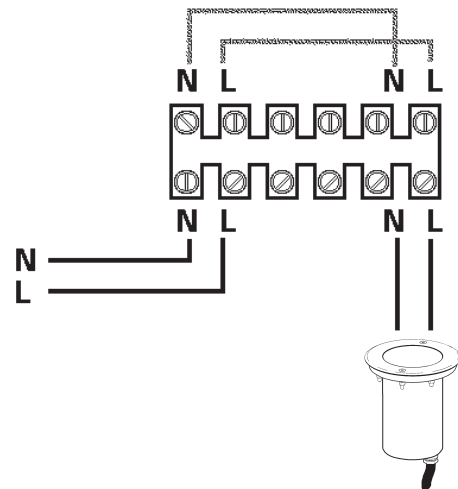
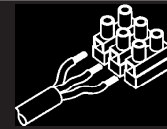

DALI

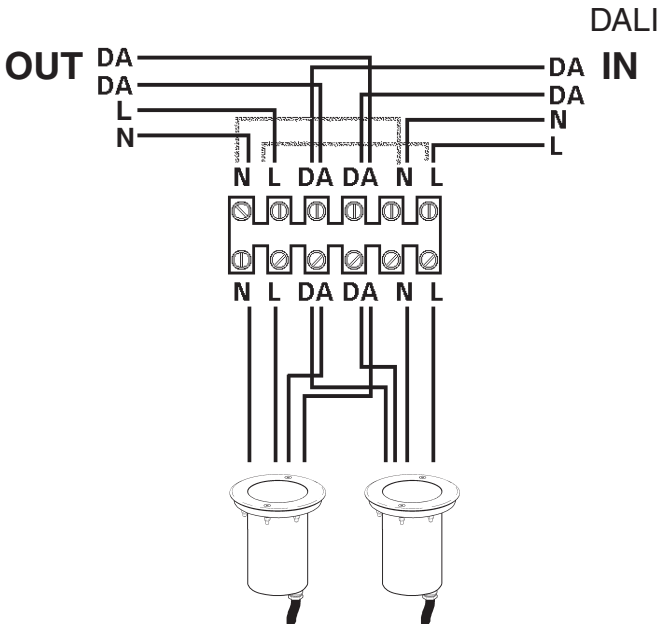
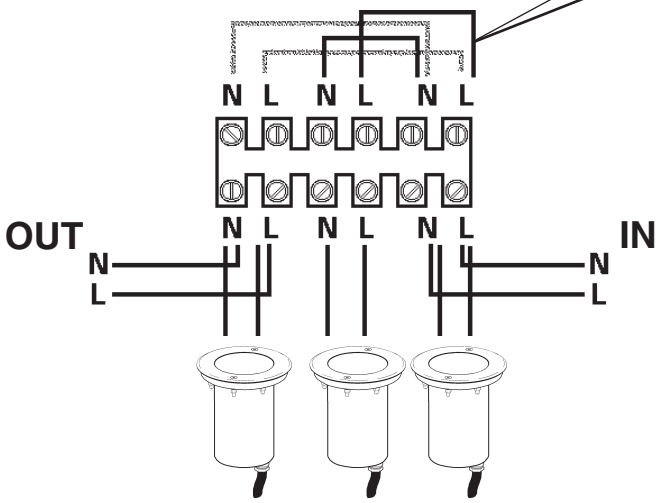
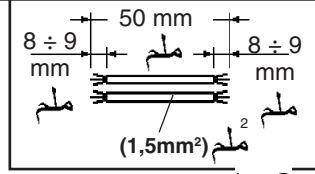
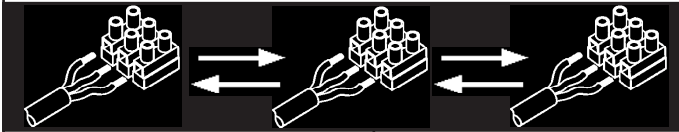
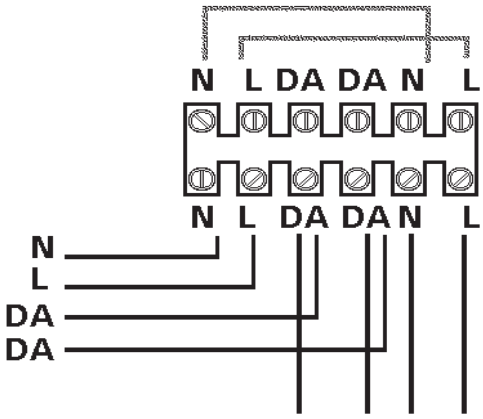

DALI

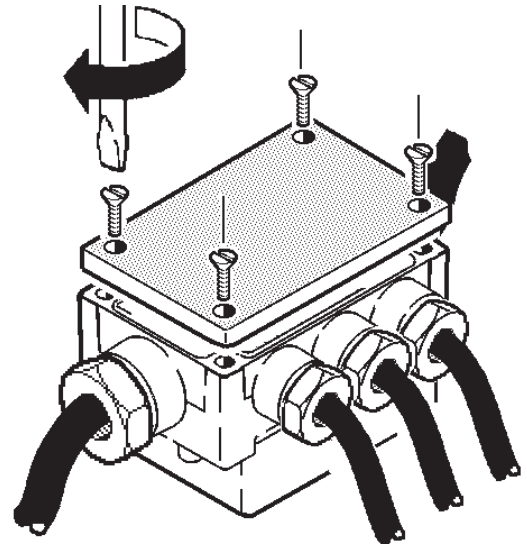

art. X188

art. X188

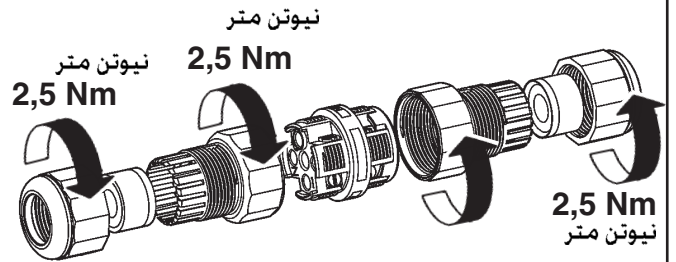
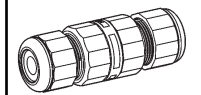

- ① ↔ ①
- ② ↔ ②
- ③ ↔ ③
- ④ ↔ ④

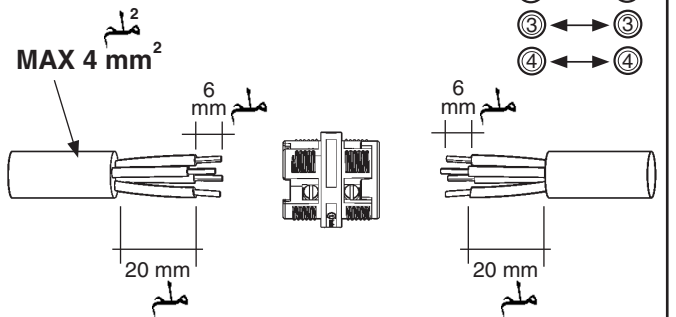

<p>D ( mm )</p>	
<p>4,5 ÷ 7 mm</p>	
<p>7 ÷ 9 mm</p>	
<p>9 ÷ 12 mm</p>	



art. X189

الصف art. X189

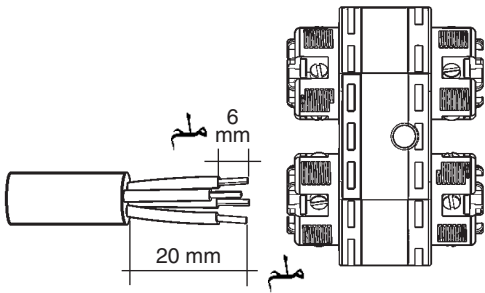
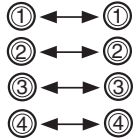
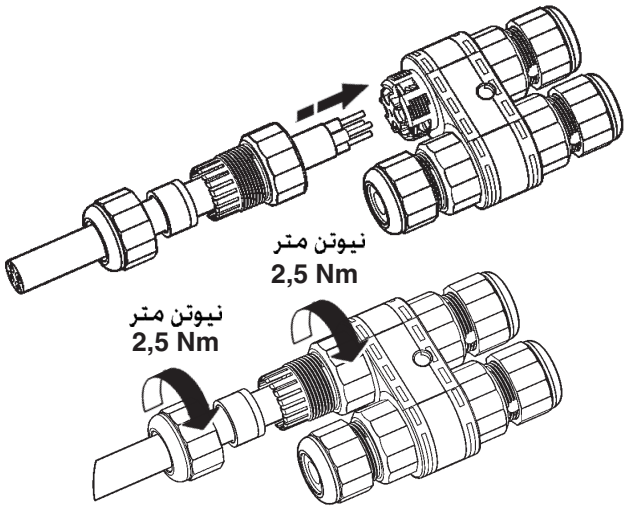

D ( mm )	
4,5 ÷ 7 mm	
7 ÷ 9 mm	
9 ÷ 12 mm	

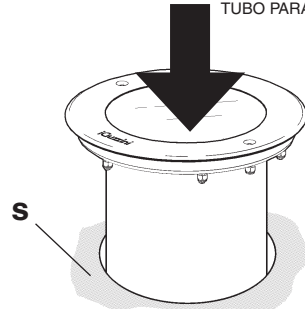
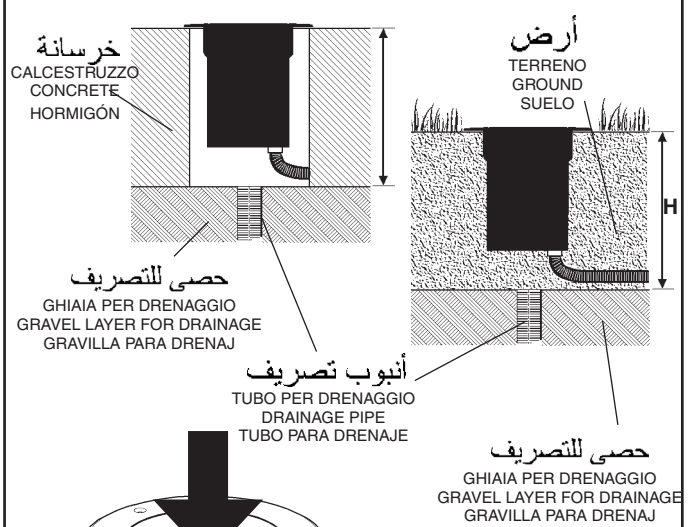

	H	
	NO DALI	DALI
Ø 144mm ملم	200mm ملم	240mm ملم
Ø 200mm ملم		210mm ملم
Ø 250mm ملم		230mm ملم    280mm ملم

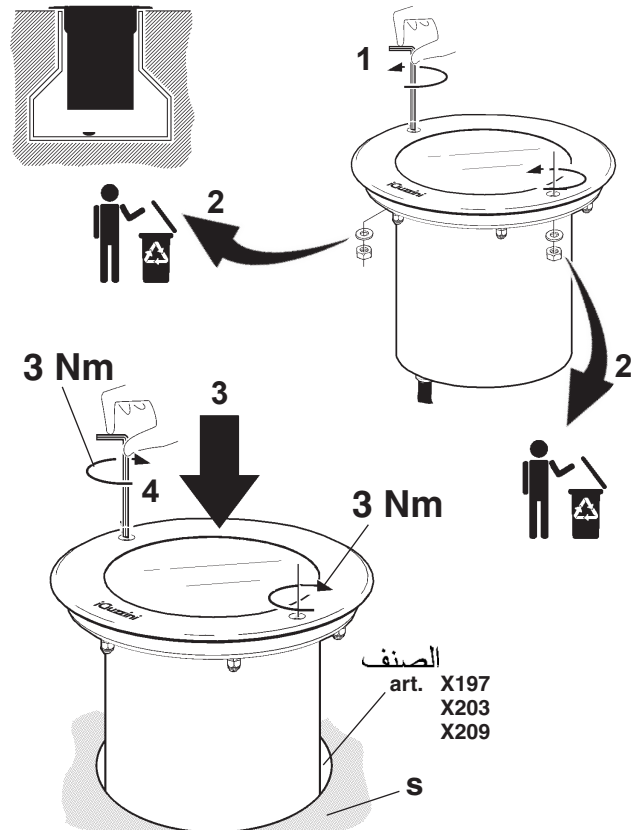

تحقق من أن المساحة "S" التي يرتكز عليها الإطار لا توجد لها أطراف متدلية.

I Accertarsi che l'area "S" sulla quale poggierà la cornice non presenti sporgenze.

GB Make sure area "S" onto which the frame will rest is free of any projections.

E Asegurarse de que el área "S", sobre la que se apoyará el marco, no presente salientes.



ضع الكيبلات على جوانب الجهاز كما هو مبين في الشكل.

I Disporre i cavi ai lati dell'apparecchio come indicato in figura.

GB Arrange the cables on the sides of the luminaire as indicated in the figure.

E Coloque los cables a los costados del aparato como lo indica la figura.

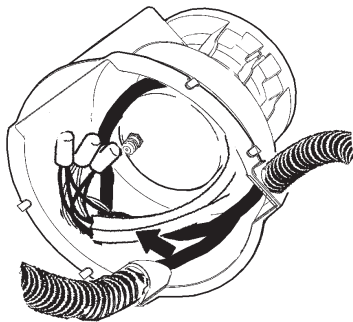
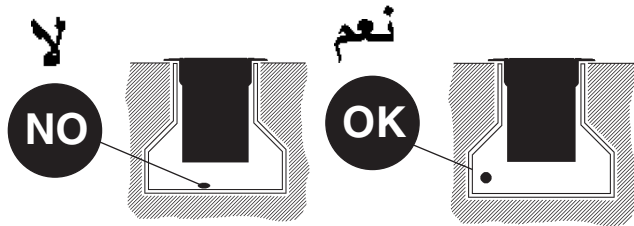

## DALI

DALI شحنة / DALI حمل  
CARICO DALI / DALI LOAD  
CHARGE DALI  
CARGA DALI

DALI عناوين  
INDIRIZZI DALI  
DALI ADDRESSES  
DIRECCIONES DALI

1 (2 mA)

1

## art. B916

الصف  
art. B916



تنبيه: لاستبدال الضوء LED اتصل بشركة iGuzzini .

I N.B.: Per la sostituzione del LED contattare l'azienda iGuzzini.

GB N.B.: For information on LED replacement please contact iGuzzini.

E NOTA: Para sustituir el LED llame a la empresa iGuzzini.

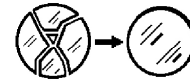

لا يمكن استعمال المنتج في حالة كسر الزجاج، وبالتالي يجب الاتصال بالصانع لاستبداله.

I In caso di rottura del vetro il prodotto non può essere utilizzato, contattare il costruttore per la sua sostituzione.

GB Should the glass break, the product cannot be used and you should contact the manufacturer for its replacement.

E No utilizar el producto en caso de ruptura del vidrio y contactar el fabricante para la sustitución.

## + ART

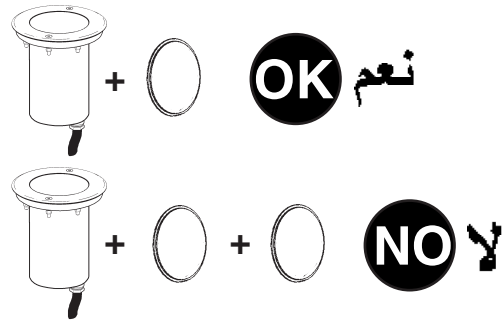

	الصنف ART.			
Ø 144mm	E112 - E113 - E114 E116 - E117 - E118 BW00 - BW01 - BW02 BW03 - BW04 - BW05	X199	X200	X198
Ø 200mm	E129 - E130 - E131 E134 - E135 - E136	X205	X206	X204
Ø 200mm	E127 - E128 - E132 E133	X240	X241	X242
Ø 250mm	E149 - E150 - E151 E152 - E153 - E154 E155 - E156 - E157 E158 - E163 - E164 E165 - E166 - E167 E168 - EI11 - EI12 EI13 - EI14 - EI15 EI16	X202	X207	X201



art. X198 - X199 - X200 - X201 - X202  
X204 - X205 - X206 - X207 - X240 - X241 - X242



تأكد من ان الطوق المثبت له بالحرف "B" موضوع كما هو في الشكل

I Assicurarsi che la guarnizione "B" sia posizionata come in figura.

GB Make sure that the seal "B" is positioned as shown in the figure.

E Comprobar que la junta "B" resulte en la posición indicada en figura.

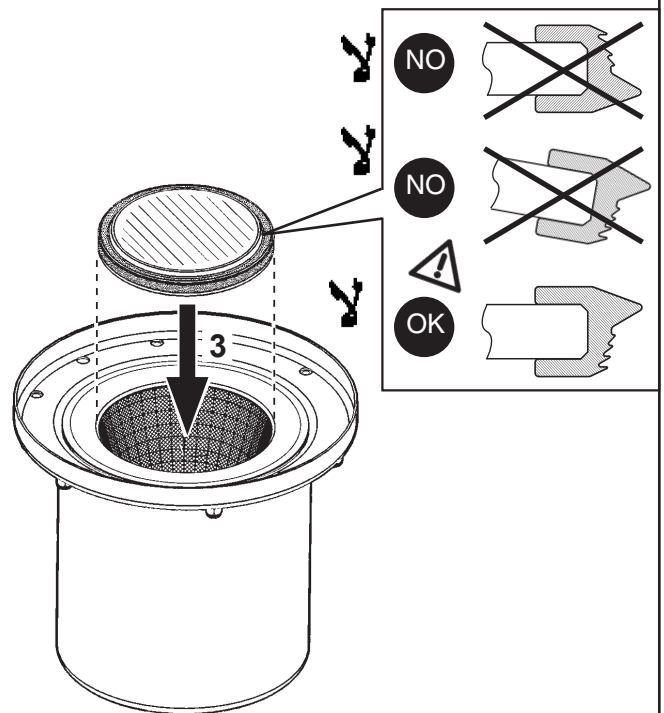



**ملاحظة:** يجب شد الصماميل التي تثبت الإطار على الجسم حتى النهاية وبشكل متجانس، وذلك من خلال الانتقال بشكل متبادل من صمولة إلى الصمولة المقابلة أثناء عملية الشد لتسهيل سحب الزجاج وبدون تلف الحشية المحيطة للمركبة، فك جميع الصماميل باستثناء صمولتين متتاليتين ثم انتظر؛ بعد ذلك فك الصمولتين المتبقيتين وأبعد الزجاج.

**I N.B.:** I dadi che fissano la cornice al corpo debbono essere serrati a fondo in modo uniforme, passando alternativamente da un dado a quello diametralmente opposto. Per facilitare l'estrazione del vetro senza danneggiare la guarnizione a cornice montata, svitare tutti i dadi ad esclusione di due consecutivi ed attendere; svitare poi i restanti dadi e togliere il vetro.

**GB N.B.:** The nuts that secure the frame to the body must be fully tightened in a uniform manner, alternating between diametrically opposed bol nuts. To facilitate the extraction of the glass without damaging the seal fitted onto the frame, unscrew all the nuts except for two adjacent ones and wait; then unscrew the remaining nuts and remove the glass.

**E Nota:** Las turcas que fijan el marco al cuerpo se deben apretar a fondo de modo uniforme, pasando alternativamente de una turca a otro diametralmente opuesto. Una vez colocado el marco, para facilitar la extracción del vidrio sin dañar la junta, desenrosque todas las tuercas que no sean consecutivas y espere, desenrosque luego las tuercas restantes y quite el vidrio.

2.510.101.03 IS11090/03	<b>iGuzzini</b>	corrente assorbita absorbed current courant absorbé Stromaufnahme stromopname corriente absorbida absorberet strøm absorbirt ström tillförd ström поглощаемая мощность 电源电流	fattore di potenza power factor facteur de puissance Leistungsfaktor vermogensfactor factor de potencia effektfaktor effektfaktor effektfaktor фактор мощности 功率因数
ART.	A	λ	
E127 - E132 - E141- E145 E149 - E154 - E169 - E173	0,05	0,93	
E170 - E171 - E172 E174 - E175 - E176	0,08	0,86	
E128 - E133 - E139 - E140	0,07	0,94	
E142 - E143 - E144 - E146 E147 - E148	0,06	0,93	
E129 - E130 - E131 - E134 E135 - E136 - E150 - E155 E161 - E162	0,06	0,95	
E112 - E113 - E114 - E116 E117 - E118	0,06	0,83	
E151 - E152 - E153 - E156 E157 - E158	0,1	0,9	
E111 - E115 - E121 - E122	0,04	0,9	
E123 - E124	0,03	0,84	
E125 - E126 - E292 - E293	0,04	0,93	
BW00 - BW01 - BW02 BW03 - BW04 - BW05	0,05	0,88	
E163 - E164 - E165 E166 - E167 - E168	0,15	0,94	
E119 - E120 - BV84 - BV85	0,06	0,89	
E137 - E138 - BV86 - BV87	0,08	0,96	
E159 - E160 - BV88 - BV89	0,11	0,9	
E111 - E112 - E113 - E114 E115 - E116	0,21	0,95	

2.510.101.03 IS11090/03	<b>iGuzzini</b>	corrente assorbita absorbed current courant absorbé Stromaufnahme stromopname corriente absorbida absorberet strøm absorbirt ström tillförd ström поглощаемая мощность 电源电流	fattore di potenza power factor facteur de puissance Leistungsfaktor vermogensfactor factor de potencia effektfaktor effektfaktor effektfaktor фактор мощности 功率因数
ART.	A	λ	
E127 - E132 - E141- E145 E149 - E154 - E169 - E173	0,05	0,93	
E170 - E171 - E172 E174 - E175 - E176	0,08	0,86	
E128 - E133 - E139 - E140	0,07	0,94	
E142 - E143 - E144 - E146 E147 - E148	0,06	0,93	
E129 - E130 - E131 - E134 E135 - E136 - E150 - E155 E161 - E162	0,06	0,95	
E112 - E113 - E114 - E116 E117 - E118	0,06	0,83	
E151 - E152 - E153 - E156 E157 - E158	0,1	0,9	
E111 - E115 - E121 - E122	0,04	0,9	
E123 - E124	0,03	0,84	
E125 - E126 - E292 - E293	0,04	0,93	
BW00 - BW01 - BW02 BW03 - BW04 - BW05	0,05	0,88	
E163 - E164 - E165 E166 - E167 - E168	0,15	0,94	
E119 - E120 - BV84 - BV85	0,06	0,89	
E137 - E138 - BV86 - BV87	0,08	0,96	
E159 - E160 - BV88 - BV89	0,11	0,9	
E111 - E112 - E113 - E114 E115 - E116	0,21	0,95	

2.510.101.03 IS11090/03	<b>iGuzzini</b>	corrente assorbita absorbed current courant absorbé Stromaufnahme stromopname corriente absorbida absorberet strøm absorbirt ström tillförd ström поглощаемая мощность 电源电流	fattore di potenza power factor facteur de puissance Leistungsfaktor vermogensfactor factor de potencia effektfaktor effektfaktor effektfaktor фактор мощности 功率因数
ART.	A	λ	
E127 - E132 - E141- E145 E149 - E154 - E169 - E173	0,05	0,93	
E170 - E171 - E172 E174 - E175 - E176	0,08	0,86	
E128 - E133 - E139 - E140	0,07	0,94	
E142 - E143 - E144 - E146 E147 - E148	0,06	0,93	
E129 - E130 - E131 - E134 E135 - E136 - E150 - E155 E161 - E162	0,06	0,95	
E112 - E113 - E114 - E116 E117 - E118	0,06	0,83	
E151 - E152 - E153 - E156 E157 - E158	0,1	0,9	
E111 - E115 - E121 - E122	0,04	0,9	
E123 - E124	0,03	0,84	
E125 - E126 - E292 - E293	0,04	0,93	
BW00 - BW01 - BW02 BW03 - BW04 - BW05	0,05	0,88	
E163 - E164 - E165 E166 - E167 - E168	0,15	0,94	
E119 - E120 - BV84 - BV85	0,06	0,89	
E137 - E138 - BV86 - BV87	0,08	0,96	
E159 - E160 - BV88 - BV89	0,11	0,9	
E111 - E112 - E113 - E114 E115 - E116	0,21	0,95	

2.510.101.03 IS11090/03	<b>iGuzzini</b>	corrente assorbita absorbed current courant absorbé Stromaufnahme stromopname corriente absorbida absorberet strøm absorbirt ström tillförd ström поглощаемая мощность 电源电流	fattore di potenza power factor facteur de puissance Leistungsfaktor vermogensfactor factor de potencia effektfaktor effektfaktor effektfaktor фактор мощности 功率因数
ART.	A	λ	
E127 - E132 - E141- E145 E149 - E154 - E169 - E173	0,05	0,93	
E170 - E171 - E172 E174 - E175 - E176	0,08	0,86	
E128 - E133 - E139 - E140	0,07	0,94	
E142 - E143 - E144 - E146 E147 - E148	0,06	0,93	
E129 - E130 - E131 - E134 E135 - E136 - E150 - E155 E161 - E162	0,06	0,95	
E112 - E113 - E114 - E116 E117 - E118	0,06	0,83	
E151 - E152 - E153 - E156 E157 - E158	0,1	0,9	
E111 - E115 - E121 - E122	0,04	0,9	
E123 - E124	0,03	0,84	
E125 - E126 - E292 - E293	0,04	0,93	
BW00 - BW01 - BW02 BW03 - BW04 - BW05	0,05	0,88	
E163 - E164 - E165 E166 - E167 - E168	0,15	0,94	
E119 - E120 - BV84 - BV85	0,06	0,89	
E137 - E138 - BV86 - BV87	0,08	0,96	
E159 - E160 - BV88 - BV89	0,11	0,9	
E111 - E112 - E113 - E114 E115 - E116	0,21	0,95	

I PERIODO GIORNALIERO DI ACCENSIONE AMMESSO

GB ALLOWED DAILY OPERATION PERIOD

F DURÉE QUOTIDIENNE D'ALLUMAGE ADMISSIBLE

D ERLAUBTE TÄGLICHE EINSCHALTDAUER

NL DAGELIJKSE ONTSTEKINGSPERIODE TOEGESTAAN

E PERIODO DIARIO DE ENCENDIDO PERMITIDO

DK TILLADT TIDSRUM FOR DAGLIG TÆNDING

N TILLATT TENNINGSTID PR. DAG

S TILLÅTEN DAGLIG PERIOD SOM PRODUKTEN KAN VARA TÄND

RUS ЕЖЕДНЕВНАЯ ДОПУСТИМАЯ ПРОДОЛЖИТЕЛЬНОСТЬ РАБОТЫ

CN 允许的日常运营周期

iGuzzini

1.154.627.01  
IS09175/01



I PERIODO GIORNALIERO DI ACCENSIONE AMMESSO

GB ALLOWED DAILY OPERATION PERIOD

F DURÉE QUOTIDIENNE D'ALLUMAGE ADMISSIBLE

D ERLAUBTE TÄGLICHE EINSCHALTDAUER

NL DAGELIJKSE ONTSTEKINGSPERIODE TOEGESTAAN

E PERIODO DIARIO DE ENCENDIDO PERMITIDO

DK TILLADT TIDSRUM FOR DAGLIG TÆNDING

N TILLATT TENNINGSTID PR. DAG

S TILLÅTEN DAGLIG PERIOD SOM PRODUKTEN KAN VARA TÄND

RUS ЕЖЕДНЕВНАЯ ДОПУСТИМАЯ ПРОДОЛЖИТЕЛЬНОСТЬ РАБОТЫ

CN 允许的日常运营周期

iGuzzini

1.154.627.01  
IS09175/01

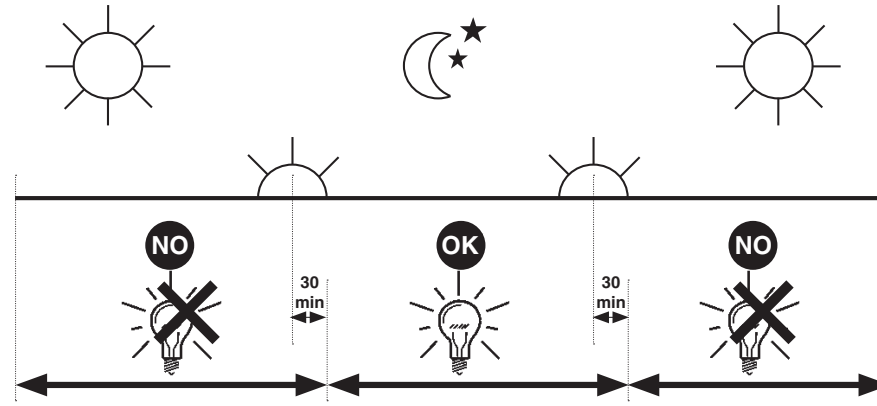

I PERIODO GIORNALIERO DI ACCENSIONE AMMESSO

GB ALLOWED DAILY OPERATION PERIOD

F DURÉE QUOTIDIENNE D'ALLUMAGE ADMISSIBLE

D ERLAUBTE TÄGLICHE EINSCHALTDAUER

NL DAGELIJKSE ONTSTEKINGSPERIODE TOEGESTAAN

E PERIODO DIARIO DE ENCENDIDO PERMITIDO

DK TILLADT TIDSRUM FOR DAGLIG TÆNDING

N TILLATT TENNINGSTID PR. DAG

S TILLÅTEN DAGLIG PERIOD SOM PRODUKTEN KAN VARA TÄND

RUS ЕЖЕДНЕВНАЯ ДОПУСТИМАЯ ПРОДОЛЖИТЕЛЬНОСТЬ РАБОТЫ

CN 允许的日常运营周期

iGuzzini

1.154.627.01  
IS09175/01



I PERIODO GIORNALIERO DI ACCENSIONE AMMESSO

GB ALLOWED DAILY OPERATION PERIOD

F DURÉE QUOTIDIENNE D'ALLUMAGE ADMISSIBLE

D ERLAUBTE TÄGLICHE EINSCHALTDAUER

NL DAGELIJKSE ONTSTEKINGSPERIODE TOEGESTAAN

E PERIODO DIARIO DE ENCENDIDO PERMITIDO

DK TILLADT TIDSRUM FOR DAGLIG TÆNDING

N TILLATT TENNINGSTID PR. DAG

S TILLÅTEN DAGLIG PERIOD SOM PRODUKTEN KAN VARA TÄND

RUS ЕЖЕДНЕВНАЯ ДОПУСТИМАЯ ПРОДОЛЖИТЕЛЬНОСТЬ РАБОТЫ

CN 允许的日常运营周期

iGuzzini

1.154.627.01  
IS09175/01

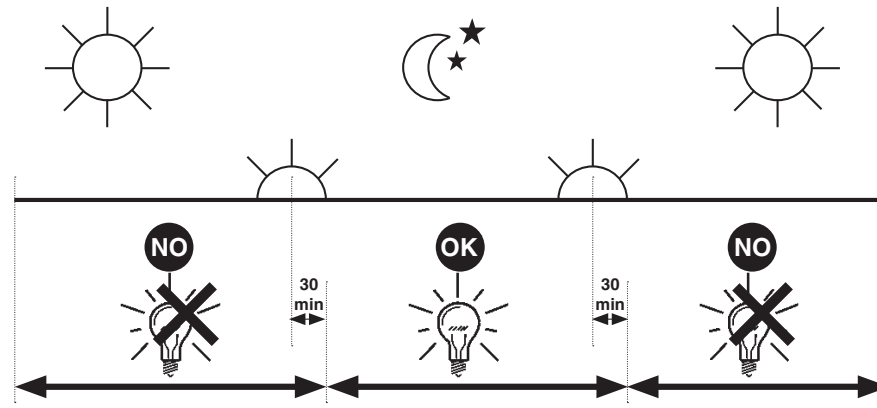

iGuzzini

2.509.386.00  
ISO9176/01

الفترة الزمنية اليومية للتشغيل المسموح بها

- I PERIODO GIORNALIERO DI ACCENSIONE AMMESSO
- GB ALLOWED DAILY OPERATION PERIOD
- E PERIODO DIARIO DE ENCENDIDO PERMITIDO

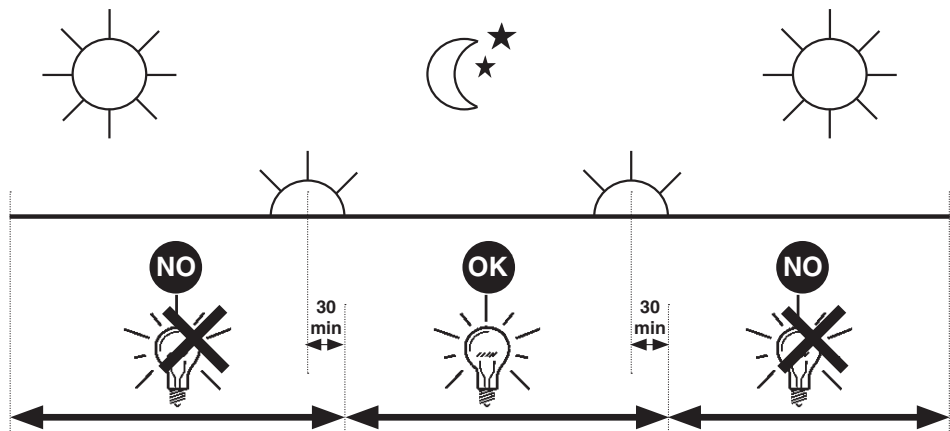

iGuzzini

2.509.386.00  
ISO9176/01

الفترة الزمنية اليومية للتشغيل المسموح بها

- I PERIODO GIORNALIERO DI ACCENSIONE AMMESSO
- GB ALLOWED DAILY OPERATION PERIOD
- E PERIODO DIARIO DE ENCENDIDO PERMITIDO

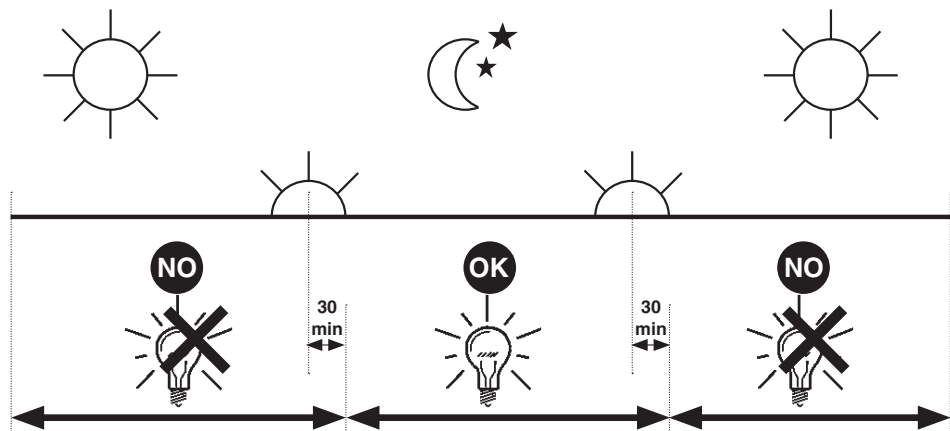

iGuzzini

2.509.386.00  
ISO9176/01

الفترة الزمنية اليومية للتشغيل المسموح بها

- I PERIODO GIORNALIERO DI ACCENSIONE AMMESSO
- GB ALLOWED DAILY OPERATION PERIOD
- E PERIODO DIARIO DE ENCENDIDO PERMITIDO

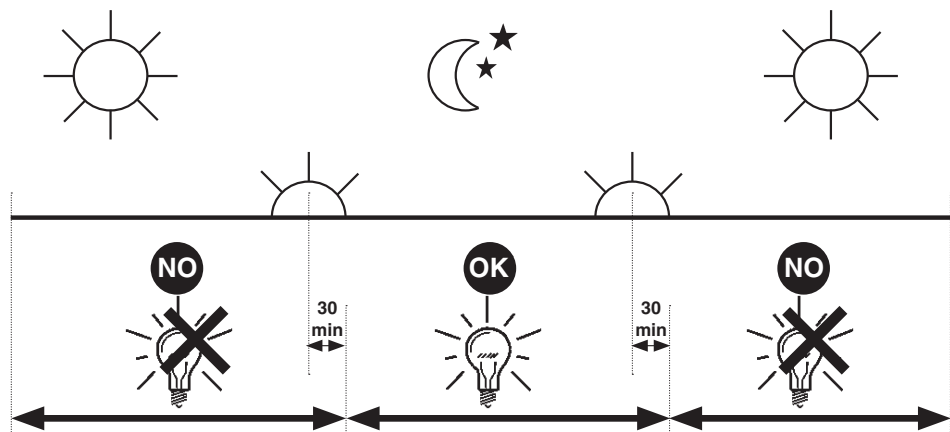

iGuzzini

2.509.386.00  
ISO9176/01

الفترة الزمنية اليومية للتشغيل المسموح بها

- I PERIODO GIORNALIERO DI ACCENSIONE AMMESSO
- GB ALLOWED DAILY OPERATION PERIOD
- E PERIODO DIARIO DE ENCENDIDO PERMITIDO

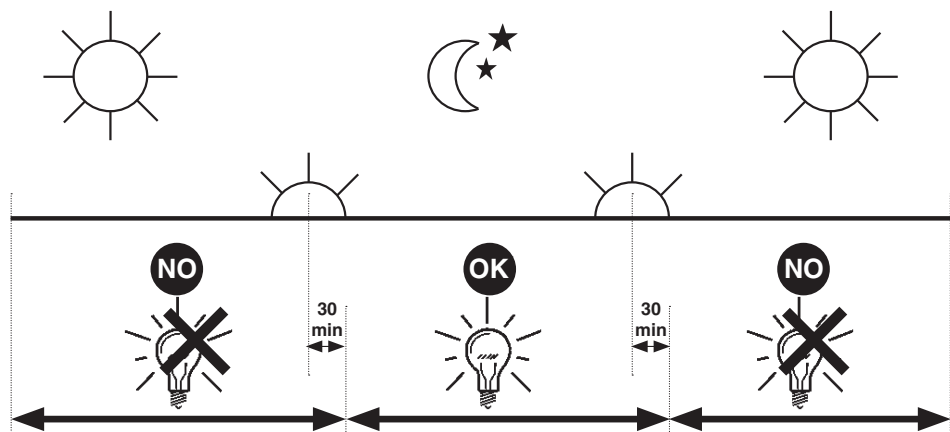

- I Istruzioni per le operazioni di servizio per l'apparecchio di illuminazione**  
**GB Instructions on luminaire service operations**  
**F Instructions pour les opérations de service du luminaire**  
**D Wartungsanleitung für die Leuchte**  
**NL Instructies voor de onderhoudsoperaties op de verlichtingsarmatuur**  
**E Instrucciones para las operaciones de servicio del aparato de alumbrado**  
**DK Anvisninger i serviceindgreb på belysningsarmatur**  
**N Anvisninger for betjening av lysapparatet**  
**S Instruktioner för användning av belysningsanordningen**  
**RUS Инструкции по эксплуатации осветительного прибора**  
**CN 照明装置检修操作说明**

**Sostituire la lampada parzialmente esausta**  
 Replace the partly exhausted lamp  
 Remplacer la lampe partiellement épuisée  
 Die teilweise erschöpfte Lampe austauschen  
 Vervang de gedeeltelijk lege lamp  
 Sustituir la lámpara parzialmente agotada  
 Udskift den delvist udtjente pære  
 Skifte ut den delvis utbrente lyspæren  
 Byt ut den delvis förbrukade lampan  
 Замена частично отработанной лампочки  
 更换部分老化的灯泡



**Spegnimento**  
 Switch it off  
 Extinction  
 Ausschaltung  
 Uitschakeling  
 Apagado  
 Slukning  
 Slukking  
 Släckning  
 Выключение  
 关灯

**Interrompere l'alimentazione dell'apparecchio**  
 Cut the power supply to the luminaire  
 Couper l'alimentation du luminaire  
 Stromversorgung der Leuchte unterbrechen  
 Onderbreek de voeding van het apparaat  
 Interrumpir la alimentación del aparato  
 Afbryd armaturets strømforsyning  
 Avbryte strømtilførselen til apparatet  
 Koppla från anordningens strömförsörjning  
 Отключить электропитание прибора  
 中断装置供电

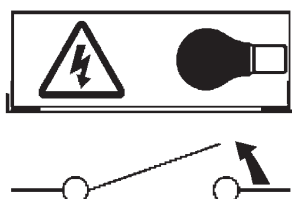

**Aprire l'apparecchio**  
 Open the fixture  
 Ouvrir le luminaire  
 Das Gerät öffnen  
 Open het apparaat  
 Abrir el aparato  
 Åbn armaturet  
 Åpne apparatet  
 Öppna anordningen  
 Раскрыть прибор  
 打开装置



**Rimuovere la lampada esausta**  
 Remove the exhausted lamp  
 Retirer la lampe épuisée  
 Die alte Lampe entnehmen  
 Verwijder de lege lamp  
 Quitar la lámpara agotada  
 Tag den udtjente pære ud  
 Fjerne den utbrente lyspæren  
 Ta bort den förbrukade lampan  
 Вынуть старую лампочку  
 取出老化的灯泡

**Portarla in un centro di riciclaggio**  
 Carry it to a recycling centre  
 La porter dans une déchetterie pour son recyclage  
 Ordnungsgemäß entsorgen  
 Breng de lamp naar een recyclingcentrum  
 Llevarla a un centro de reciclaje  
 Aflever den på en genbrugsstation  
 Lever den til en miljøstasjon  
 Lämna in den till en återvinningsanläggning  
 Сдать ее в пункт приема утильсырья  
 将其送往回收中心



**Inserire la nuova lampada**  
 Introduce the new lamp  
 Installer la lampe neuve  
 Die neue Lampe einsetzen  
 Doe de nieuwe lamp op zijn plek  
 Montar la nueva lámpara  
 Sæt den nye pære i  
 Sette i den nye pæren  
 Sätt i den nya lampan  
 Вставить новую лампочку  
 装入新灯泡

**Inserire la nuova lampada nel portalampana**  
 Fit the new lamp into the socket  
 Installer la nouvelle lampe dans le support de lampe  
 Die neue Lampe in den Sockel einsetzen  
 Doe de nieuwe lamp in de lamphouder  
 Montar la nueva lámpara en el portalampana  
 Sæt den nye pære i fatningen  
 Sette den nye pæren inn i lampeholderen  
 Sätt i den nya lampan i lamphållaren  
 Вставить новую лампочку в патрон  
 将新灯泡插入灯泡架中



**Riposizionare ottica**  
 Re-place the optic  
 Remettre l'optique à sa place  
 Die Optik wieder einsetzen  
 Doe de optiek weer op zijn plaats  
 Volver a montar la óptica  
 Sæt den optiske enhed på plads  
 Innstille linsen  
 Flytta om optiken  
 Отрегулировать линзы  
 重新定位光头

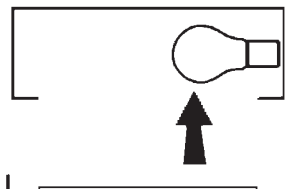

**Effettuare prova di funzionamento**  
 Perform operative test  
 Procéder à un essai de fonctionnement  
 Eine Funktionsprüfung durchführen  
 Controleer de correcte werking  
 Hacer una prueba de funcionamiento  
 Afprøv funktionen  
 Prøve om den fungerer  
 Utför funktionstest  
 Выполнить проверку исправности работы  
 执行功能测试

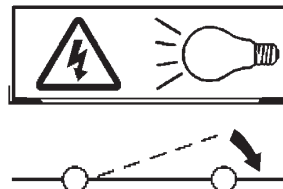



I Istruzioni per la pulizia dell'apparecchio di illuminazione  
 GB Instructions on luminaire cleaning operations  
 F Instructions pour le nettoyage du luminaire  
 D Anweisungen zur Reinigung der Leuchte  
 NL Instructies voor de reiniging van de verlichtingsarmatuur  
 E Instrucciones para limpiar el aparato de alumbrado  
 DK Anvisninger i rengøring af belysningsarmaturet  
 N Anvisninger for rengjøring av lysapparatet  
 S Instruktioner för rengöring av belysningsanordningen  
 RUS Инструкции по чистке осветительного прибора  
 CN 照明装置清洁说明

Pulire l'apparecchio  
 Clean the fixture  
 Nettoyer le luminaire  
 Das Gerät reinigen  
 Reinig het apparaat  
 Limpiar el aparato  
 Rengør armaturet  
 Rengjøre apparatet  
 Rengör anordningen  
 Чистка прибора  
 清洁装置



Spegnimento  
 Switch it off  
 Extinction  
 Ausschaltung  
 Uitschakeling  
 Apagado  
 Slukning  
 Slukking  
 Släckning  
 Выключение  
 关灯

Interrompere l'alimentazione dell'apparecchio  
 Cut the power supply to the luminaire  
 Couper l'alimentation du luminaire  
 Stromversorgung der Leuchte unterbrechen  
 Onderbreek de voeding van het apparaat  
 Interrumpir la alimentación del aparato  
 Afbryd armaturets strømforsyning  
 Avbryt strømtilførselen til apparatet  
 Koppla från anordningens strömförsörjning  
 Отключить электропитание прибора  
 中断装置供电



Spolverare l'ottica esterna  
 Remove dust from the external optic  
 Dépoussiérer l'optique extérieure  
 Die externe Optik abstauben  
 Stof de externe optiek af  
 Quitar el polvo de la óptica exterior  
 Tør støvet af den udvendige optiske enhed  
 Fjerne støv fra den eksterne lysenheden  
 Damma av den yttre optiken  
 Вытереть пыль с внешней стороны линз  
 为外侧光头掸尘



Lavare l'ottica esterna  
 Wash the external optic  
 Laver l'optique extérieure  
 Die externe Optik waschen  
 Was de externe optiek  
 Lavar la óptica exterior  
 Vask den udvendige optiske enhed  
 Vaske den eksterne lysenheden  
 Rengör den yttre optiken  
 Вымыть линзы с внешней стороны  
 清洁外光头



Rimuovere l'ottica  
 Remove the optic  
 Retirer l'optique  
 Die Optik abnehmen  
 Verwijder de optiek  
 Quitar la óptica  
 Tag den optiske enhed af  
 Fjerne lysenheden  
 Ta bort optiken  
 Снять линзы  
 取下光头



Pulire la parte interna dell'apparecchio di illuminazione  
 Clean the inside of the fixture  
 Nettoyer l'intérieur du luminaire  
 Die Innenseite der Leuchte reinigen  
 Reinig de binnenzijde van de verlichtingsarmatuur  
 Limpiar el interior del aparato de alumbrado  
 Rengør belysningsarmaturets indvendige dele  
 Rengjøre lysapparatet innvendig  
 Rengör belysningsanordningen invändigt  
 Протереть осветительный прибор изнутри  
 清洁照明装置内部



Riposizionare ottica  
 Re-place the optic  
 Remettre l'optique à sa place  
 Die Optik wieder einsetzen  
 Doe de optiek weer op zijn plaats  
 Volver a montar la óptica  
 Sæt den optiske enhed på plads  
 Innstille linsen  
 Flytta om optiken  
 Отрегулировать линзы  
 重新定位光头



Effettuare prova di funzionamento  
 Perform operative test  
 Procéder à un essai de fonctionnement  
 Eine Funktionsprüfung durchführen  
 Controleer de correcte werking  
 Hacer una prueba de funcionamiento  
 Afprøv funktionen  
 Prøve om den fungerer  
 Utför funktionstest  
 Выполнить проверку исправности работы  
 执行功能测试



- I Istruzioni per il fine vita e lo smaltimento dei componenti**  
**GB Instructions on end-of-life and component disposal**  
**F Instructions pour la gestion des composants en fin de vie et leur mise au rebut**  
**D Anweisungen zur Entsorgung der Leuchtenkomponenten**  
**NL Instructies voor het verwijderen van de armatuur en het recyclen van de onderdelen**  
**E Instrucciones para el final de vida y la eliminación los componentes**  
**DK Anvisninger i udtjent armatur og bortskaffelse af komponenter**  
**N Anvisninger for endt levetid og avfallsbehandling av delene**  
**S Instruktionser vid bortskaffning och kassering av komponenter**  
**RUS Инструкции по утилизации прибора и его комплектующих по окончании его срока службы**  
**CN 寿命期结束与零件废弃处置说明**

<p>Spegnimento Switch it off Extinction Ausschaltung Uitschakeling Apagado Slukning Slukking Släckning Выключение 关灯</p> <p>Interrompere l'alimentazione dell'apparecchio Cut the power supply to the luminaire Couper l'alimentation du luminaire Stromversorgung der Leuchte unterbrechen Onderbreek de voeding van het apparaat Interrompirla alimentación del aparato Afbryd armaturets strømforsyning Avbryt strømtilførselen til apparatet Koppla från anordningens strömförsörjning Отключить электропитание прибора 中断装置供电</p> 	<p>Rimuovere la/e lampada/e per la dismissione Remove the lamp(s) for decommissioning Retirer la(les) lampe(s) pour sa(leur) mise au rebut Die Lampe/n ordnungsgemäß entsorgen Verwijder de lamp(en) voor het recyclen Quitar la(s) lámpara(s) para el desecho Tag pæren/pærerne ud til bortskaffelse Fjerne lampen/-e som skal kastes Ta bort lampan/-orna för bortskaffningen Вынуть лампочку/и для утилизации прибора 取出需要丢弃的灯泡</p> 	<p>Rimuovere la batteria per la dismissione Remove the battery for decommissioning Retirer la batterie pour sa mise au rebut Die Batterie ordnungsgemäß entsorgen Verwijder de batterij voor het recyclen Quitar la batería para el desecho Tag batteriet ud til bortskaffelse Fjerne batteriet som skal kastes Ta bort batteriet för bortskaffningen Вынуть батарейку для утилизации прибора 取出需要丢弃的电池</p> 	<p>Rimuovere l'apparecchio per la dismissione Remove the fixture for decommissioning Enlever le luminaire pour sa mise au rebut Das Gerät ordnungsgemäß entsorgen Verwijder het apparaat voor het recyclen Quitar el aparato para el desecho Tag armaturet ud til bortskaffelse Fjerne apparatet som skal kastes Ta bort anordningen för bortskaffningen Снять прибор для утилизации 取出需要丢弃的装置</p> 
---	--	--	--

<p>Inviare i materiali ad un centro di raccolta RAEE Send the materials to a WEEE collection centre Envoyer les matériaux dans une déchetterie DEEE Die Materialien in einem WEEE-Zentrum entsorgen Zend de materialen naar een recyclingscentrum voor de AEEA Enviar los materiales a un centro de recogida RAEE Afløver materialerne på et indsamlingscenter for elektronisk udstyr Sende materialene til en miljøstasjon for resirkulering av EE-avfall Skicka materialet till en RAEE uppsamlingscentral Сдать материалы в пункт приема утильсырья 将材料送往电气和电子垃圾回收中心</p> 			
--	--	--	--