

LIGHT UP EARTH ADJUSTABLE

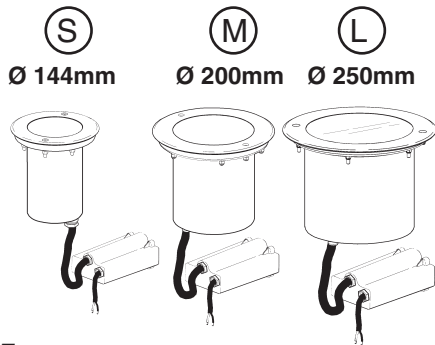

ATTENZIONE:

LA SICUREZZA DELL'APPARECCHIO E' GARANTITA SOLO CON L'USO APPROPRIATO DELLE SEGUENTI ISTRUZIONI; PERTANTO E' NECESSARIO CONSERVARLE.

GB WARNING:

THE SAFETY OF THIS FIXTURE IS GUARANTEED ONLY IF YOU COMPLY WITH THESE INSTRUCTIONS; REMEMBER TO CONSERVE IN A SAFE PLACE.

F ATTENTION:

LA SECURITE DE L'APPAREIL N'EST GARANTIE QU'EN CAS D'UTILISATION CORRECTE DES INSTRUCTIONS SUIVANTES; IL FAUT PAR CONSEQUENT LES CONSERVER.

D ACHTUNG:

DIE SICHERHEIT DES GERÄTES WIRD NUR DURCH SACHGEMÄSSE BEFOLGUNG NACHSTEHENDER ANWEISUNGEN GEWÄHRLEISTET; IHRE AUFBEWAHRUNG IST DESHALB SEHR WICHTIG.

NL OPGELET:

DE VEILIGHEID VAN DI ATOESTEL IS SLECHTS DAN GEGARANDEERD ALS INDIEN DE VOLGENDE INSTRUCITIES STRIKT WORDEN TOEGEPAST: DAAROM MOET MEN ZE OOK BEWAREN.

E ATENCION:

LA SEGURIDAD DEL APARATO SE GARANTIZA SOLO CUMPLIENDO CUIDADOSAMENTE LAS SIGUIENTES INSTRUCCIONES; POR ELLO, ES NECESARIO CONSERVARLAS.

DK BEMÆRK:

SIKKERHEDEN VED BRUG AF ARMATURET KAN KUN GARANTERES, HVIS DISSE ANVISNINGER FØLGES; SØRG DERFOR FOR AT GEMME DEM.

N ADVARSEL:

SIKKERHETEN TIL DETTE APPARATET GARANTERES KUN HVIS DU OVERHOLDER DISSE INSTRUKSJONENE; HUSK Å OPPBEVARE DEM PÅ ET TRYGT STED.

S OBSERVERA!

UTRUSTNINGENS SÄKERHET KAN ENDAST GARANTERAS OM DESSA ANVISNINGAR RESPEKTERAS I DETALJ. SPARA DÄRFÖR DESSA ANVISNINGAR FÖR FRAMTIDA KONSULTATION.

RUS ВНИМАНИЕ:

МЫ ГАРАНТИРУЕМ БЕЗОПАСНУЮ ЭКСПЛУАТАЦИЮ ИЗДЕЛИЯ ТОЛЬКО ПРИ СОБЛЮДЕНИИ СЛЕДУЮЩИХ ИНСТРУКЦИЙ; С ЭТОЙ ЦЕЛЬЮ НЕОБХОДИМО СОХРАНИТЬ ДАННУЮ БРОШЮРУ.

CN 警告

为确保该装置安全，请遵守操作指示；并于安全场所放置。

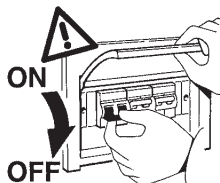

I N.B.: Apparecchi non idonei ad essere coperti di materiale termicamente isolante

GB N.B.: Fixtures not suitable to be covered in thermally-insulating material.

F N.B.: Appareils ne pouvant pas être couverts de matériau d'isolation thermique

D N.B.: Geräte nicht geeignet, um mit wärmeisolierendem Material abgedeckt zu werden

NL N.B.: Deze apparaten zijn niet geschikt om te worden bedekt met thermisch isolerend materiaal

E NOTA: Aparatos no aptos para ser cubiertos de material térmicamente aislante

DK N.B.: Armaturerne må ikke dækkes af varmeisolerende materiale.

N N.B.: Apparatene passer ikke til å dekkes av termoisolerende materialer.

S OBS! Utrustningen får inte täckas över med värmeisolerande material

RUS Внимание: Приборы непригодны для покрытия термоизоляционным материалом.

CN 灯具不适宜用隔热材料加以覆盖。



I Per la disposizione dei tubi corrugati e/o dei cavi elettrici, fare riferimento al progetto dell'impianto.

GB See the system project for the arrangement of the corrugated pipes and/or electric cables.

F Pour la disposition des conduits annelés et/ou des câbles électriques, veuillez vous reporter au projet de l'installation.

D Zur Verlegung der flexiblen Leerrohre und/oder der Elektrokabel verweisen wir auf das Anlageprojekt.

NL Het rangschikken van de gegolfde buizen en/of de elektrische kabels moet u uitvoeren op basis van de gegevens die u in het ontwerp van het systeem terugvindt.

E Para la ubicación de los tubos corrugados y/o de los cables eléctricos, hágase referencia al proyecto de la instalación.

DK Se anlægsudformningen for placering af bølgerør og/eller elektriske ledninger.

N Se systemprosjektet for ordningen av korrugerte rør og/eller elektriske kabler.

S För dragningen av korrugerade rör och/eller elkablar hänvisas till systemets projekt.

RUS Расположение гофрированных труб и/или электропроводки смотрите в проекте системы.

CN 针对波纹管和/或电缆的排列，参见系统设计。

N.B.: DURANTE L'INSTALLAZIONE DEL SISTEMA RISPETTARE SCRUPOLOSAMENTE LE NORME IMPIANTISTICHE NAZIONALI VIGENTI.

N.B.: WHEN INSTALLING THE SYSTEM, MAKE SURE ALL CURRENT NATIONAL REGULATIONS RELATING TO INSTALLATION ARE OBSERVED.

N.B.: LORS DE L'INSTALLATION DU SYSTÈME VEUILLEZ RESPECTER RIGOREUSEMENT LES NORMES EN VIGUEUR EN LA MATIÈRE DANS LE PAYS.

N.B.: BEACHTEN SIE BEI DER INSTALLATION DES SYSTEMS UNBEDINGT DIE IM LAND GELTENDEN ANLAGETECHNISCHEN VORSCHRIFTEN.

N.B.: BIJ HET INSTALLEREN VAN HET SYSTEEM MOET U DE GELDENDE NATIONALE INSTALLATIENORMEN STRIKT NALEVEN.

NOTA: DURANTE LA INSTALACIÓN DEL SISTEMA RESPETAR ESCRUPULOSAMENTE LAS NORMAS NACIONALES DE INSTALACIÓN EN VIGOR.

N.B.: UNDER INSTALLATION AF SYSTEMET SKAL MAN NØJE OVERHOLDE DE GÆLDENDE REGLER FOR DISSE ANLÆG.

N.B.: UNDER INSTALLASJON AV SYSTEMET MÅ DE NASJONALE ANLEGGSFORSKRIFTENE OVERHOLDES NØYE.

OBS! UNDER INSTALLATIONEN AV SYSTEMET SKA GÄLLANDE NATIONELLA INSTALLATIONSFÖRESKRIFTER RESPEKTERAS I DETALJ.

ПРИМЕЧАНИЕ: В ПРОЦЕССЕ МОНТАЖА СИСТЕМЫ СТРОГО СОБЛЮДАЙТЕ НАЦИОНАЛЬНЫЕ ДЕЙСТВУЮЩИЕ НОРМАТИВЫ ПО ЭЛЕКТРОПРОВОДКЕ.

注意：安装系统时请务必遵守系统标准。

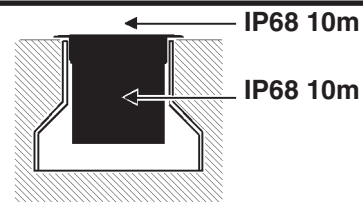

I Gli apparecchi sono stati progettati e collaudati per reggere un carico statico fino a 50000 N e resistere alle sollecitazioni di percorrenza. L'installazione non è ammessa in zone di utilizzo di spalaneve e con carrabilità a velocità superiori ai 50 Km/h.

GB The lighting fixtures were designed and tested to withstand a static load of up to 50000 N and to resist drive-over stress. The fixtures may not be installed in areas where snowplows are used, or where the drive-over speed exceeds 50 km/h.

F Les appareils ont été spécialement conçus et testés pour supporter une charge statique pouvant atteindre 50000 N et résister aux contraintes de circulation. L'installation n'est pas permise dans des zones d'utilisation de chasse-neige et où la vitesse de circulation dépasse 50 Km/h.

D Bei der Entwicklung und Prüfung der Leuchten wurde sichergestellt, dass sie einer statischen Belastung von bis zu 50000 N sowie den Belastungen, denen sie auf viel befahrenen Straßen ausgesetzt sind, standhalten. Die Leuchten dürfen nicht in Bereichen installiert werden, in denen Schneeräumfahrzeuge eingesetzt werden, oder auf Straßen, die mit einer Geschwindigkeit von mehr als 50 km/h befahren werden.

NL De apparaten zijn ontworpen en goedgekeurd voor het dragen van een statische lading tot aan 50000 N en het weerstaan van de druk van overgaand verkeer. Installaties in gebieden waar sneeuwpløegen worden gebruikt en waar verkeer sneller dan 50 km/h passeert is niet toegestaan.

E Los aparatos han sido proyectados y probados para soportar una carga estática máxima de 50000 N y resistir a los esfuerzos derivados del tránsito. La instalación no está admitida en zonas donde se utilizan máquinas para espalar la nieve y donde esté permitido el tráfico a velocidades superiores a los 50 Km/h.

DK Armaturerne er udviklet og afprøvet til en statisk belastning på op til 50000 N og kan modstå forbigående belastning. Installation er ikke tilladt i områder, hvor der køres snepløje og hvor der køres hurtigere end 50 km/t.

N Lysarmaturer ble designet og testet for å tåle en statisk belastning på inntil 50000 N og motstå overkjøringsbelastning. Armaturerne kan ikke installeres i områder der det brukes snøpløyer, eller der overkjøringshastigheten overstiger 50 km/t.

S Utrustningarna har tillverkats och testats för att tåla en statisk belastning på upp till 50000 N och tåla förbipasserande belastningar. Installationen är inte tillåten i områden där snöplög används eller där fordon passerar med en hastighet över 50 km/h.

RUS Приборы спроектированы и испытаны на статическую нагрузку вплоть до 50000 N и выдерживают динамическую нагрузку. Не допускается монтаж в зонах работы

CN 这些装置经过设计并且核查时可以承担最大重量至 50000 N 公斤的，并且能够承受路面载荷。在铲雪车经过以及通车速度时速超过50公里的地方不可以安装

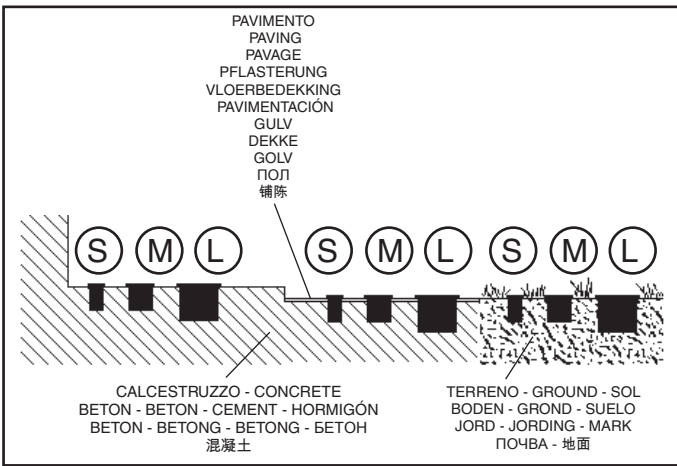

I Si consiglia di proteggere adeguatamente il cavo dal contatto diretto con il terreno.
GB The cable should be suitably protected against direct contact with the ground.
F Nous conseillons de protéger adéquatement le câble du contact direct avec le sol.
D Es wird empfohlen, das Kabel ausreichend vor dem direkten Kontakt mit dem Erdreich zu schützen.
NL Geadviseerd wordt om de kabel adequaat te beschermen tegen direct contact met de grond.
E Se recomienda proteger adecuadamente el cable del contacto directo con el terreno.
DK Det anbefales at beskytte kablet på passende vis mod direkte kontakt med jorden.
N Vi anbefaler at kablen beskyttes tilstrekkelig fra kontakt med bakken.
S Det rekommenderas att skydda kablarna så att den inte är i direkt kontakt med marken.
RUS Рекомендуется защитить надлежащим образом кабель от прямого контакта с землей.
CN 建议采取适当的方式保护电缆，防止其与地面直接接触。

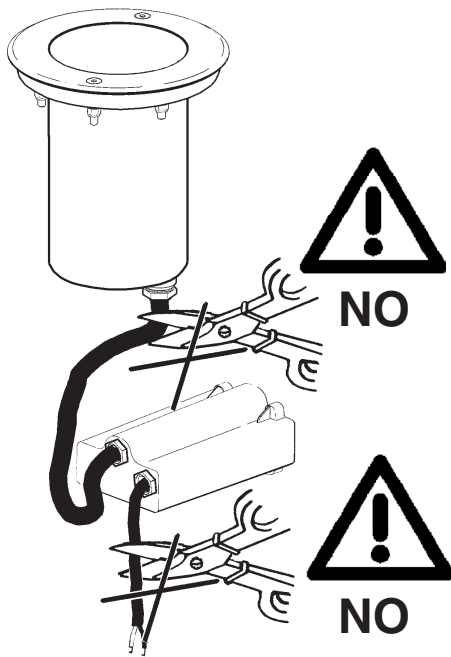

I In caso di danneggiamento del cavo flessibile esterno, questo deve essere sostituito dal costruttore, o dal suo servizio di assistenza, o da personale qualificato equivalente, al fine di evitare pericoli.
GB Should the outer flexible cable be somehow damaged, the latter should be replaced by the manufacturer, or by the corresponding service centre, or by an appropriate and qualified member of staff in order to avoid all risk of danger.
F Si le câble flexible extérieur est abîmé, faites-le remplacer par le fabricant, par son service après-vente ou par un professionnel du secteur agréé afin d'éviter tout danger.
D Sollte das äußere Kabel beschädigt sein, so muss es aus Sicherheitsgründen vom Hersteller, dessen Kundendienst oder von dazu autorisiertem Personal ausgewechselt werden.
NL Mocht de externe flexibele slang beschadigd worden, dan moet deze worden vervangen door de fabrikant of door een bevoegde installateur, zodat eventueel gevaar vermeden wordt.
E En caso de daños el cable flexible externo debe substituirse por el fabricante, su servicio de asistencia o personal calificado equivalente para evitar peligros.
DK Hvis den yderste ledning beskadiges, skal den udskiftes af producenten eller er et autoriseret teknisk servicecenter, eller af kvalificerede fagfolk, så man undgår farlige situationer.
N Hvis ytre fleksible kabel skulle bli skadet, skal denne skiftes ut av produsenten eller tilsvarende servicesenter eller av en egnet og kvalifisert fagperson for å unngå farens risiko.
S Om den yttre kabeln skadas ska den bytas ut av tillverkaren, av dess auktoriserade verkstad eller av likvärdig kvalificerad personal för att undvika alla typer av risker.
RUS В случае повреждения внешнего гибкого кабеля во избежание риска поручите его замену производителю, уполномоченному сервису или квалифицированному электрику.
CN 如果外部软缆损坏，须由生产商、对应服务中心或能胜任和资深的员工更换新的电缆，以避免任何可能的危险。

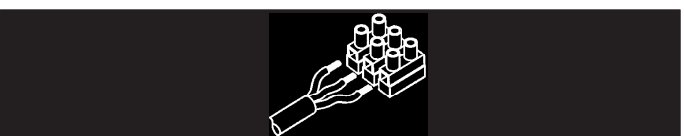
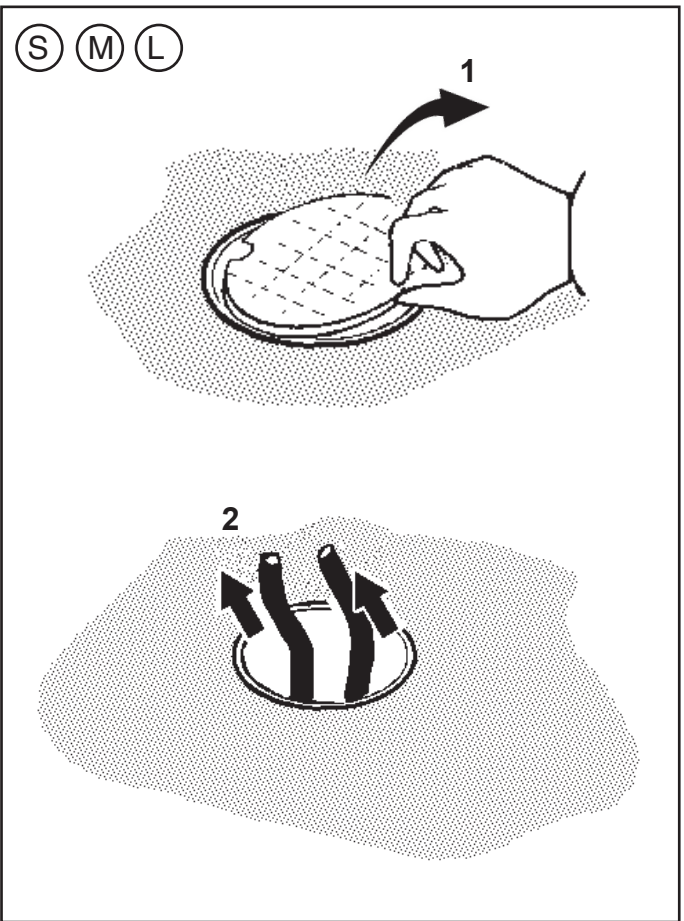

220/240 V

NASTRO AUTOAGGLOMERANTE
 SELF-VULCANISING TAPE
 RUBAN AUTO-SOUDABLE
 SELBSTHAFTBAND - (Klebefilm SCOTCH 23 3M)
 ZELFFUSERENDE TAPE
 CINTA AUTOAGLOMERANTE (SCOTCH 23 3M)
 SELVKLÆBENDE BÅND
 SELVVULKANISERENDE TAPE
 SJÄLVBINDANDE BAND
 САМОПЛАСТИФИЦИРУЮЩАЯСЯ ЛЕНТА
 自硫化带

art. 9581

art. B915

art. X188

art. X189

ALIMENTAZIONE
 POWER SUPPLY
 ALIMENTATION
 ZUFUHR
 VOEDING
 ALIMENTACION
 STRÖMFORSYNING
 STROMFORSYNING
 ELFÖRSÖRJNING
 ЭЛЕКТРОПИТАНИЕ
 电源

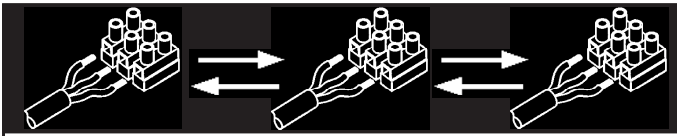

220/240 V

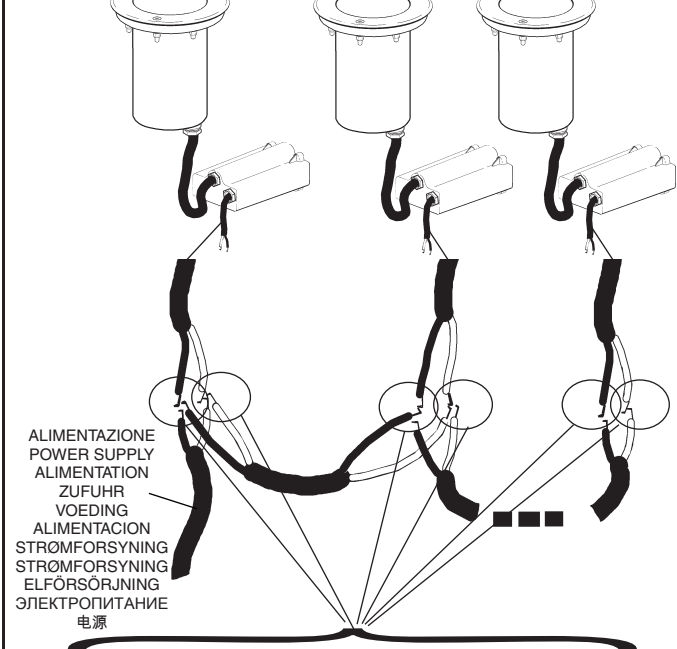

ALIMENTAZIONE
POWER SUPPLY
ALIMENTATION
ZUFUHR
VOEDING
ALIMENTACION
STRØMFORSYNING
STRØMFORSYNING
ELFORSØRNING
ЭЛЕКТРОПИТАНИЕ
电源

NASTRO AUTOAGGLERANTE
SELF-VULCANISING TAPE
RUBAN AUTO-SOUDABLE
SELBSTHAFTBAND - (Klebefilm SCOTCH 23 3M)
ZELFFUSERENDE TAPE
CINTA AUTOAGGLERANTE
(SCOTCH 23 3M)
SELVKLÆBENDE BÅND
SELVVULKANISERENDE TAPE
SJÄLVBINDANDE BAND
САМОПЛАСТИФИЦИРУЮЩАЯ ЛЕНТА
自硫化帶

art. 9581

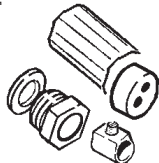

art. B915

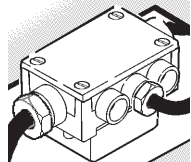

art. X189

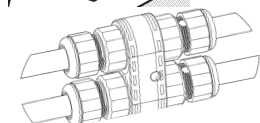

NASTRO AUTOAGGLERANTE
SELF-VULCANISING TAPE
RUBAN AUTO-SOUDABLE
SELBSTHAFTBAND - (Klebefilm SCOTCH 23 3M)
ZELFFUSERENDE TAPE
CINTA AUTOAGGLERANTE
(SCOTCH 23 3M)
SELVKLÆBENDE BÅND
SELVVULKANISERENDE TAPE
SJÄLVBINDANDE BAND
САМОПЛАСТИФИЦИРУЮЩАЯ ЛЕНТА
自硫化帶

NASTRO AUTOAGGLERANTE
SELF-VULCANISING TAPE
RUBAN AUTO-SOUDABLE
SELBSTHAFTBAND - (Klebefilm SCOTCH 23 3M)
ZELFFUSERENDE TAPE
CINTA AUTOAGGLERANTE
(SCOTCH 23 3M)
SELVKLÆBENDE BÅND
SELVVULKANISERENDE TAPE
SJÄLVBINDANDE BAND
САМОПЛАСТИФИЦИРУЮЩАЯ ЛЕНТА
自硫化帶

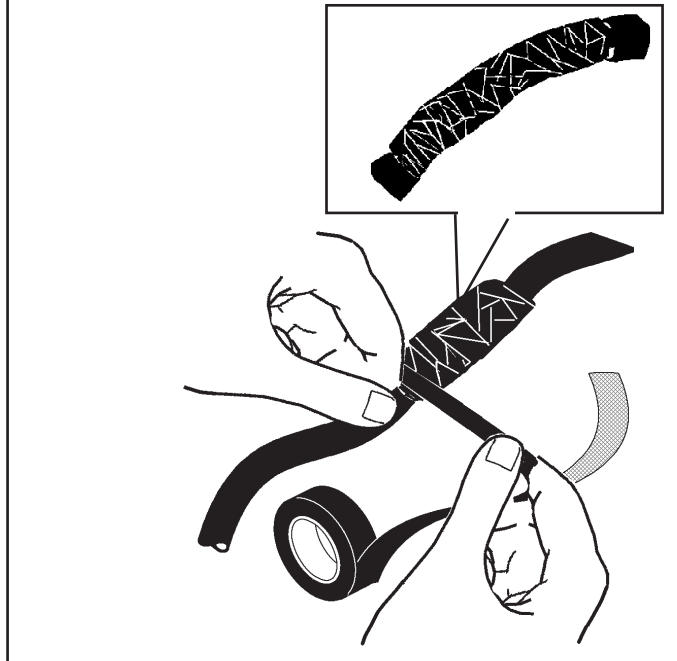
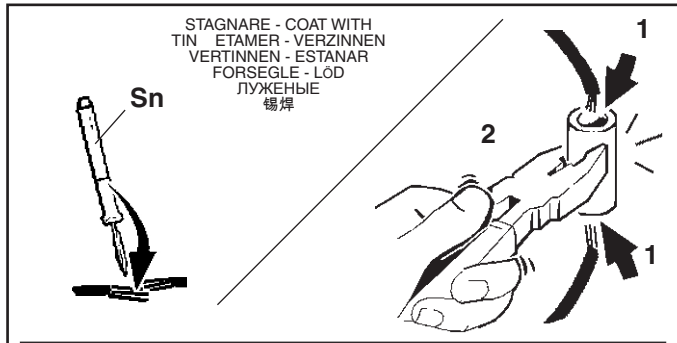
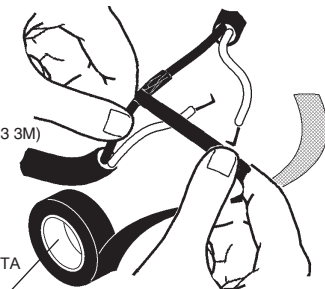

art. 9581

art. 9581

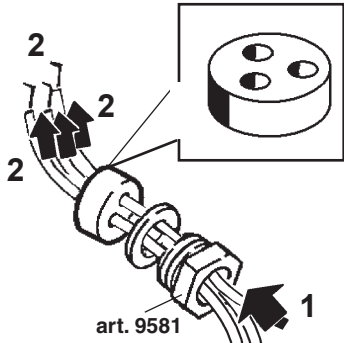
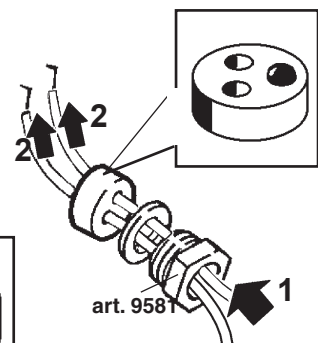
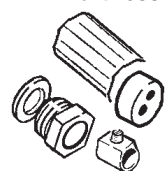

art. 9581

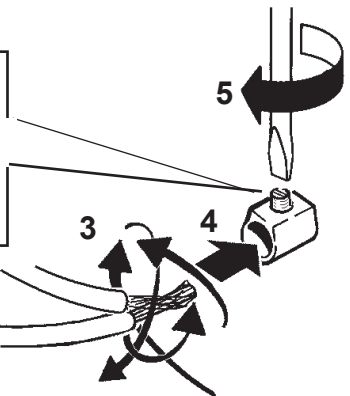
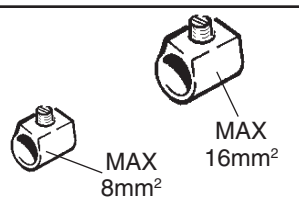

art. B915

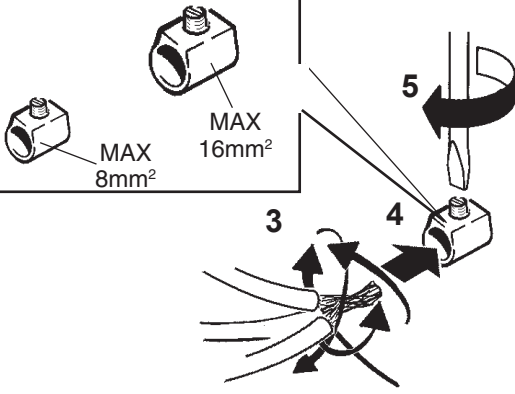

- I N.B.: Verificare manualmente la tenuta dei cavi nel morsetto.
- GB N.B.: Manually check the tightness of the cables in the terminal board.
- F N.B.: Veuillez vérifier manuellement la tenue des fils dans la borne.
- D NB: Der Halt der Drähte in der Klemme ist von Hand zu prüfen.
- NL N.B.: Verifieer handmatig of de kabels goed in de klemmenstrook vastzitten.
- E N.B.: Verificar manualmente la fijación de los cables en el terminal.
- DK N.B.: Kontrollér, at ledningerne i klemmen sidder ordentligt fast.
- N N.B.: Kontrollér tettheten til kablene i terminalkortet manuelt.
- S OBS! Kontrollera för hand att kablarna sitter ordentligt fast i klämman.
- RUS ПРИМЕЧАНИЕ: Проверьте вручную прочность соединения проводов к клеммам.
- CN 注意: 手动检查接线排电缆的牢固性。

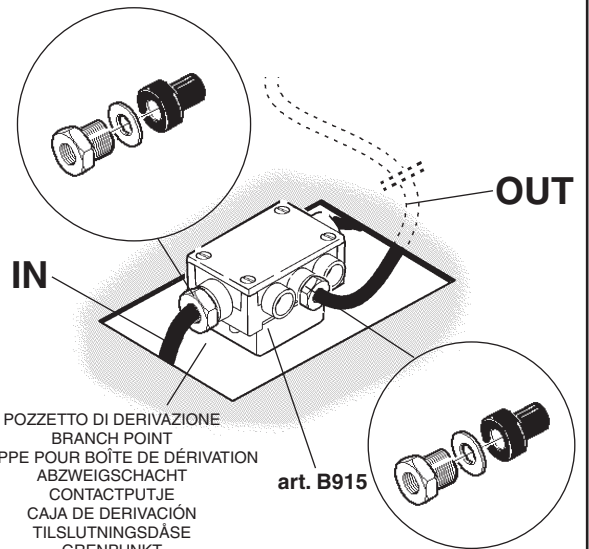

POZZETTO DI DERIVAZIONE
 BRANCH POINT
 TRAPPE POUR BOÎTE DE DÉRIVATION
 ABZWEIGSCHACHT
 CONTACTPUTJE
 CAJA DE DERIVACIÓN
 TILSLUTNINGSDÅSE
 GRENPUNKT
 KOPPLINGSBRUNN
 УЗЛОВАЯ ТОЧКА
 分支点

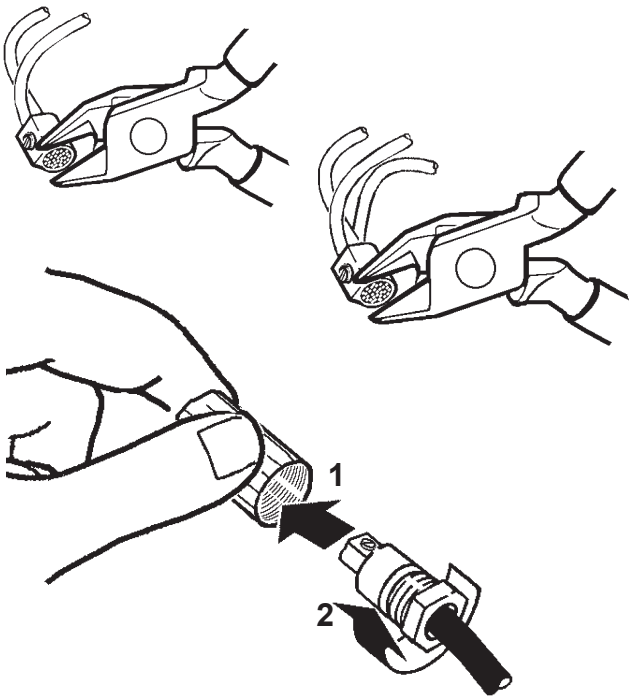

NASTRO AUTOAGGLOMERANTE
 SELF-VULCANISING TAPE
 RUBAN AUTO-SOUDABLE
 SELBSTHAFTBAND - (Klebefilm SCOTCH 23 3M)
 ZELFFUSERENDE TAPE
 CINTA AUTOAGLOMERANTE
 (SCOTCH 23 3M)
 SELVKLÆBENDE BÅND
 SELVVULKANISERENDE TAPE
 SJÄLVBINDANDE BAND
 САМОПЛАСТИФИЦИРУЮЩАЯСЯ ЛЕНТА
 自硫化帶

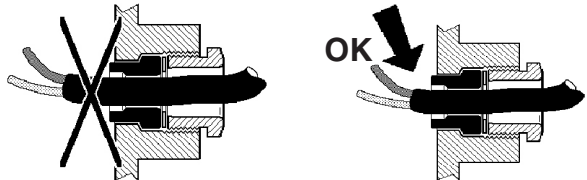
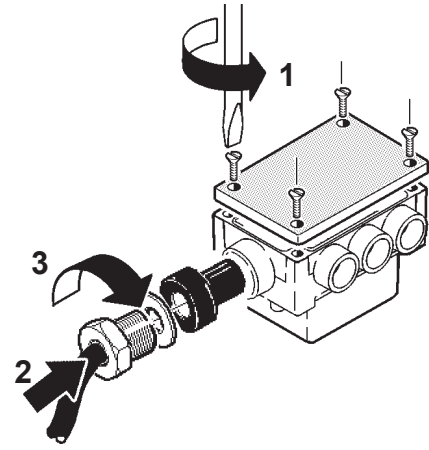
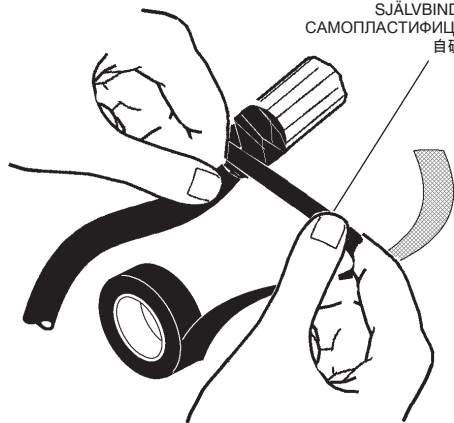

D (mm)	Ø (mm)
8,0 ÷ 10,0	8,5
10,0 ÷ 12,5	11
12,5 ÷ 14,5	13,5
14,5 ÷ 16,0	15,5

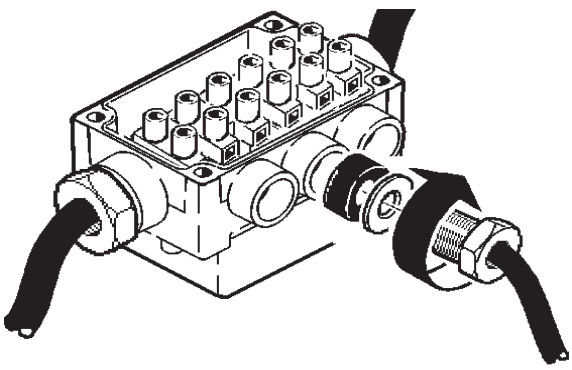

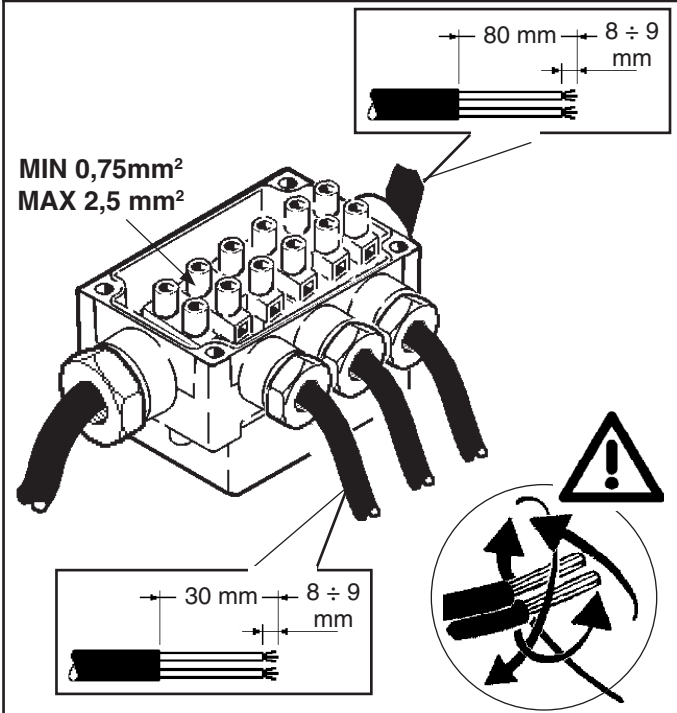
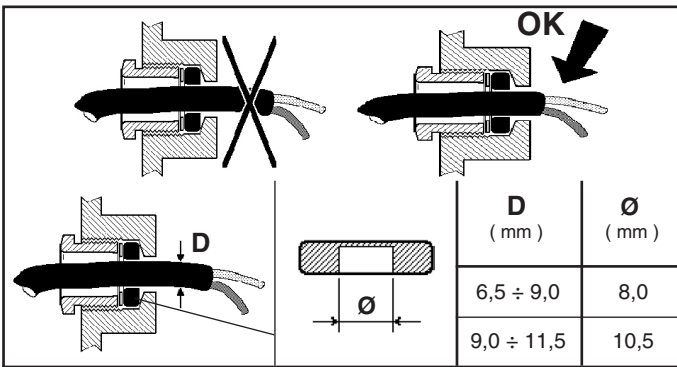

- I N.B.: Verificare manualmente la tenuta dei cavi nel morsetto.
- GB N.B.: Manually check the tightness of the cables in the terminal board.
- F N.B.: Veuillez vérifier manuellement la tenue des fils dans la borne.
- D NB: Der Halt der Drähte in der Klemme ist von Hand zu prüfen.
- NL N.B.: Verifieer handmatig of de kabels goed in de klemmenstrook vastzitten.
- E N.B.: Verificar manualmente la fijación de los cables en el terminal.
- DK N.B.: Kontrollér, at ledningerne i klemmen sidder ordentligt fast.
- N N.B.: Kontrollér tettheten til kablene i terminalkortet manuelt.
- S OBS! Kontrollera för hand att kablarna sitter ordentligt fast i klämman.
- RUS ПРИМЕЧАНИЕ: Проверьте вручную прочность соединения проводов к клеммам.
- CN 注意：手动检查接线排电缆的牢固性。

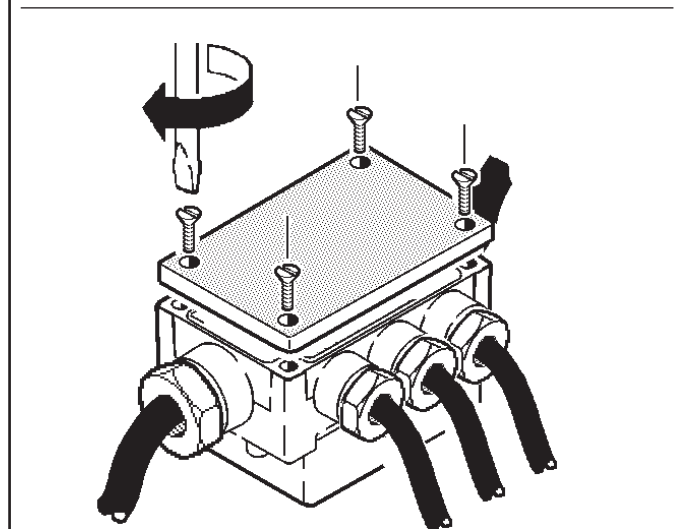
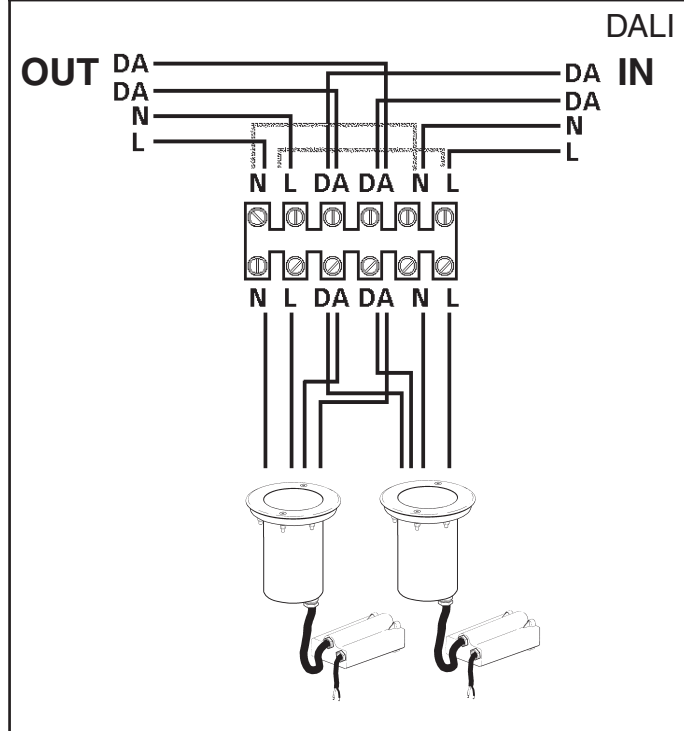
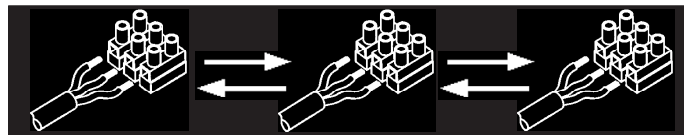
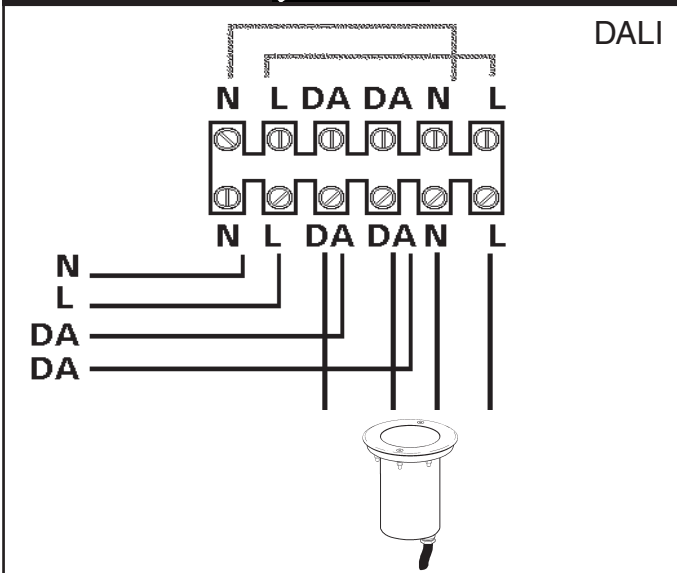
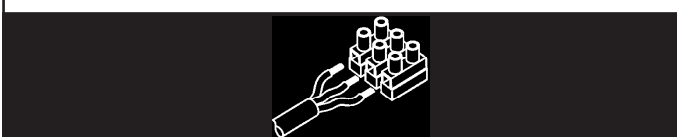

art. X188

art. X188

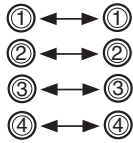
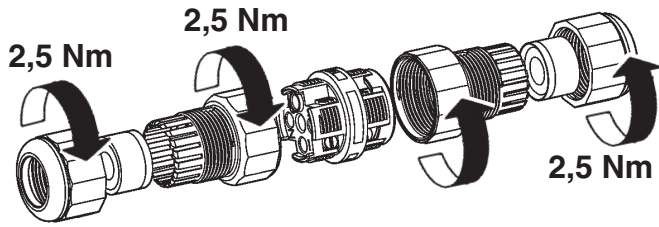
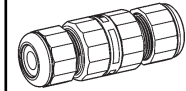

MAX 4 mm²

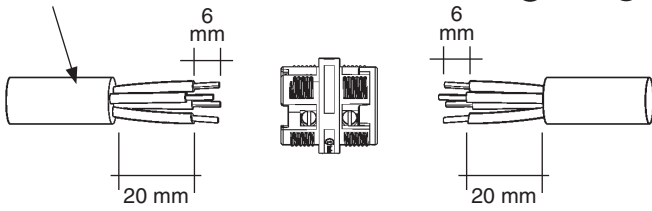

D (mm)	
2,5 ÷ 4,5 mm	
4,5 ÷ 7 mm	
7 ÷ 9 mm	
9 ÷ 12 mm	

art. X189

art. X189

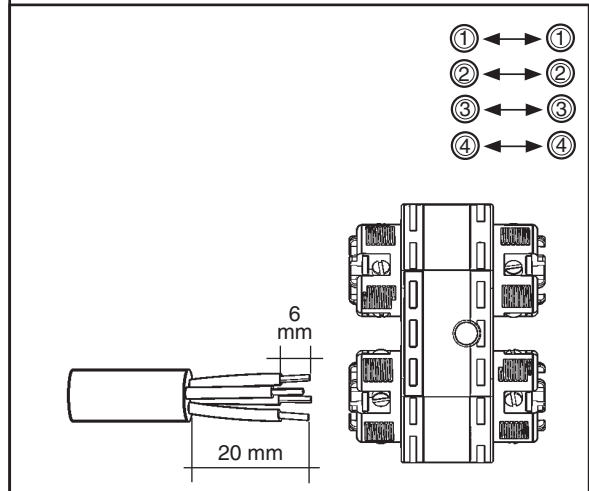
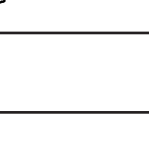
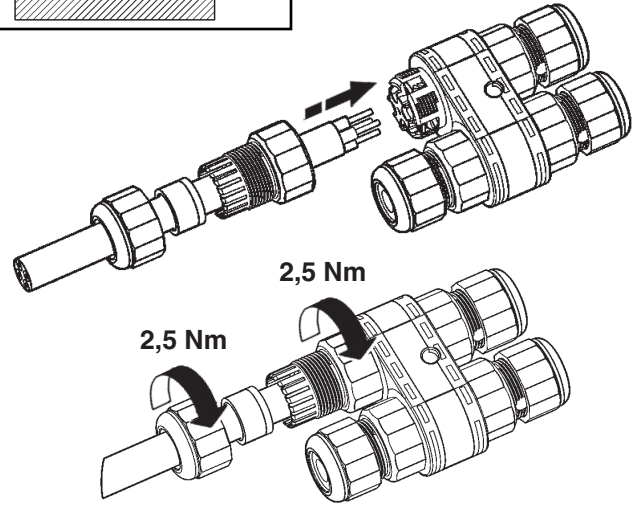
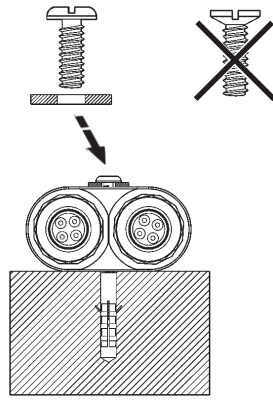

D (mm)	
2,5 ÷ 4,5 mm	
4,5 ÷ 7 mm	
7 ÷ 9 mm	
9 ÷ 12 mm	

ORIENTAMENTO DEL VANO OTTICO
 ADJUSTING THE POSITION OF THE OPTICAL ASSEMBLY
 ORIENTATION DU GROUPE OPTIQUE
 AUSRICHTEN DES LAMPENANSCHLUSSES
 HET RICHTEN VAN HET VERLICHTINGSARMATUUR
 ORIENTABILIDAD DE LA OPTICA
 INDSTILLING AF DEN OPTISKE ENHED
 JUSTERING AV POSISJONEN PÅ DEN OPTISKE ENHETEN
 RIKTNING AV OPTISKT RUM
 ОРИЕНТАЦИЯ ЛАМПОВОГО ОТСЕКА
 可调光的位置

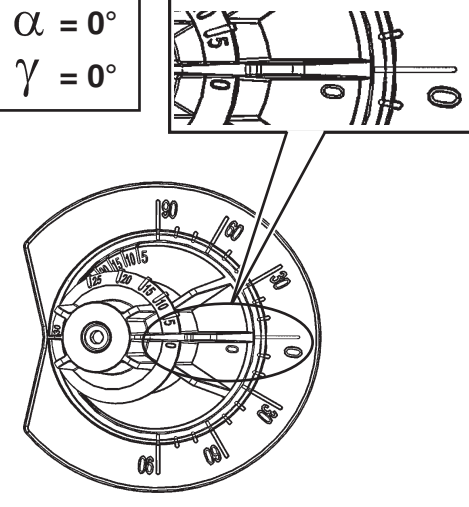
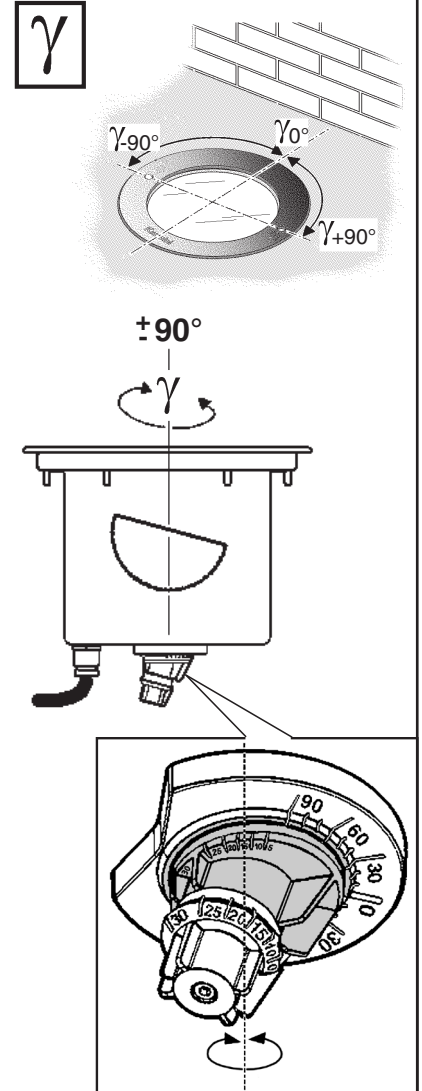
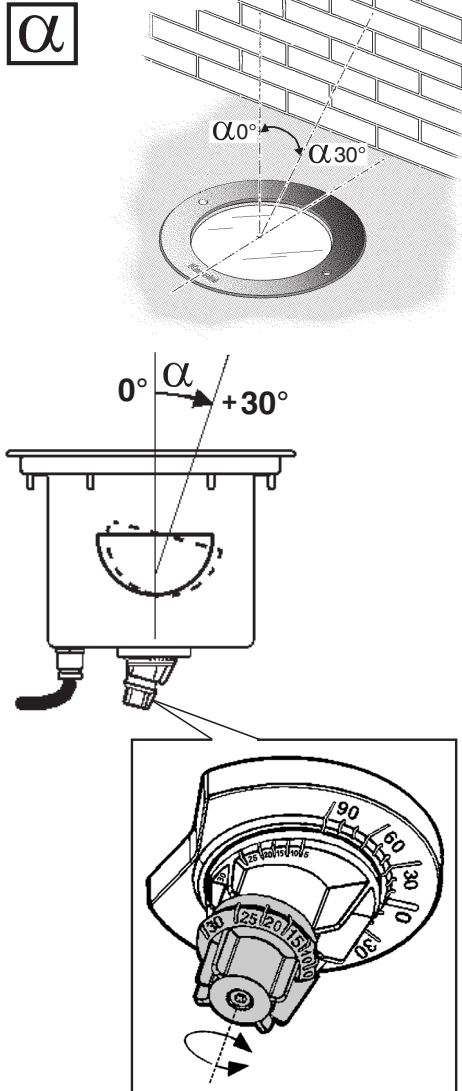
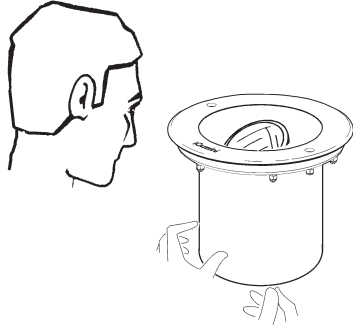

ESEMPI - EXAMPLES - EXEMPLES - BEISPIELE - VOORBEELDEN - EJEMPLOS - EKSEMPLENE - EXEMPLEN - ПРИМЕРОВ - 例子

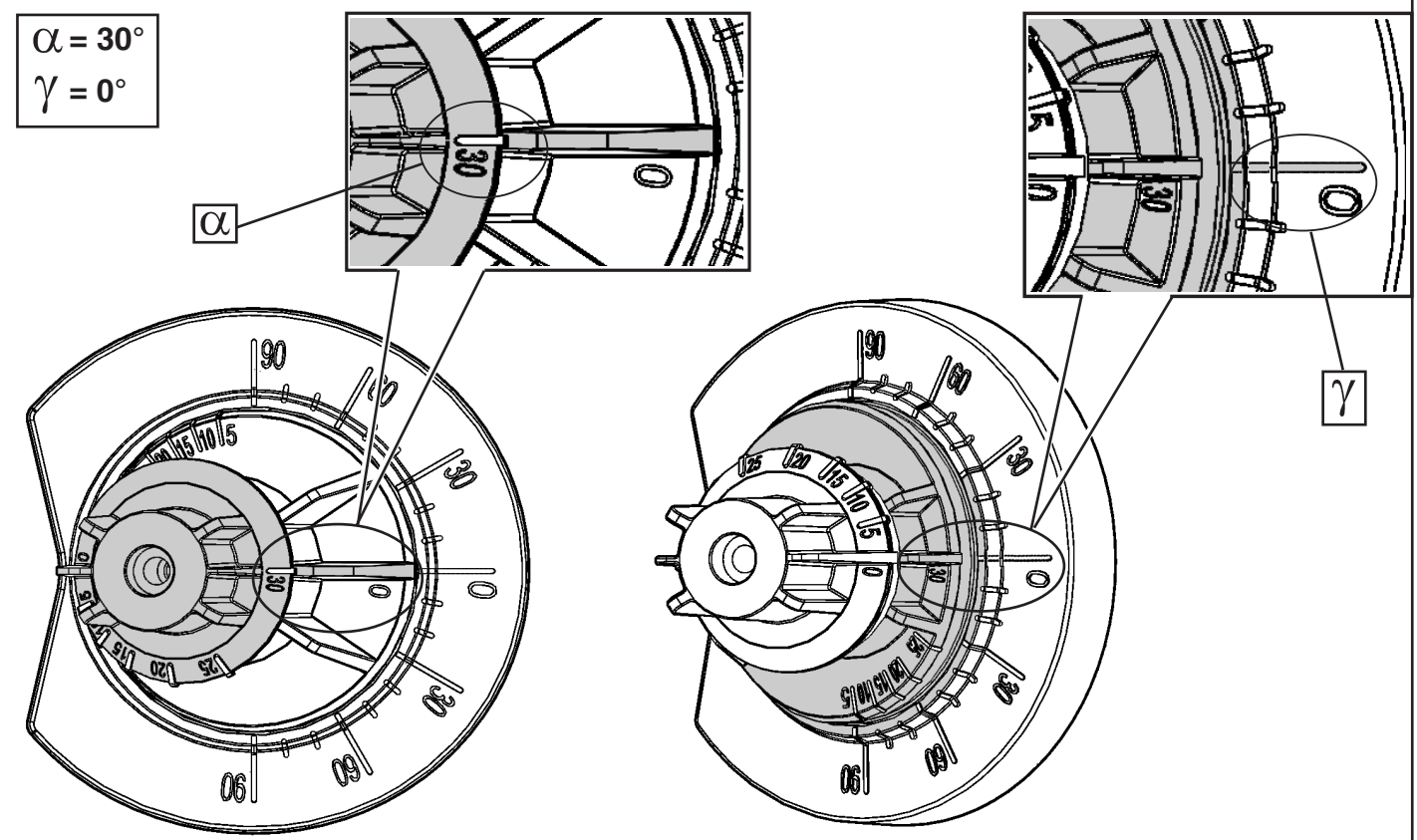

$\alpha = 15^\circ$
 $\gamma = 0^\circ$

α

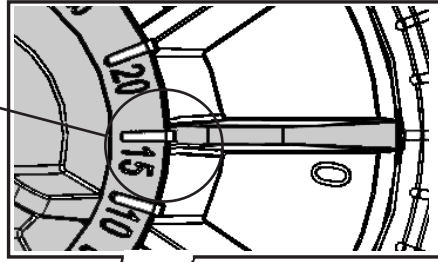

γ

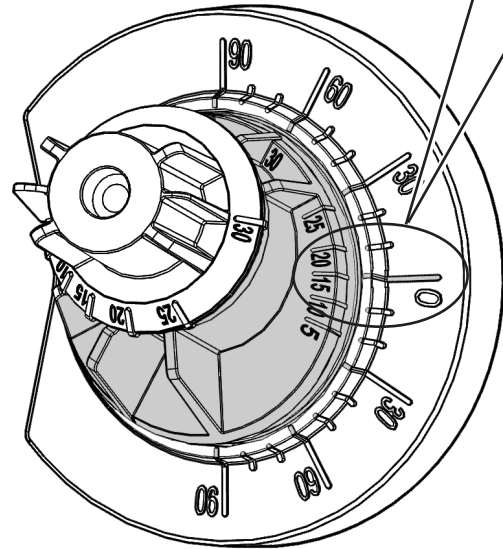
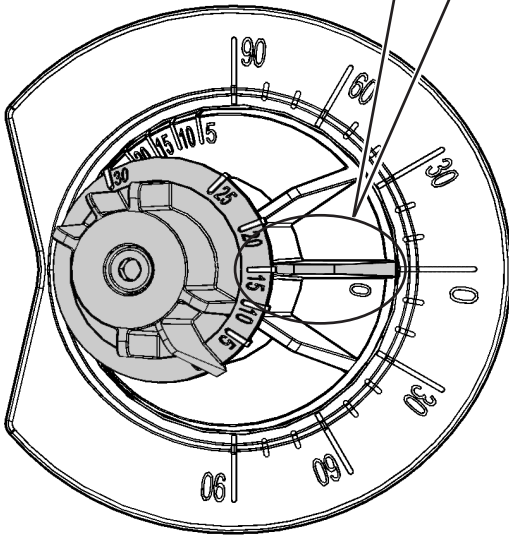
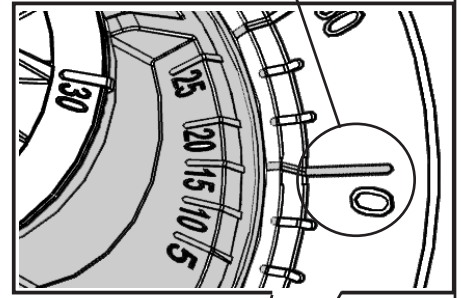

$\alpha = 15^\circ$
 $\gamma = 60^\circ$

α

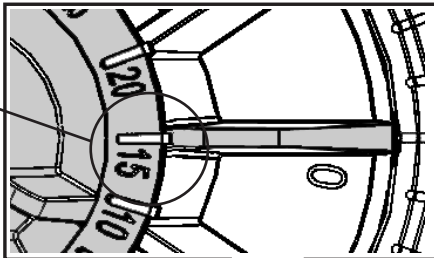

γ

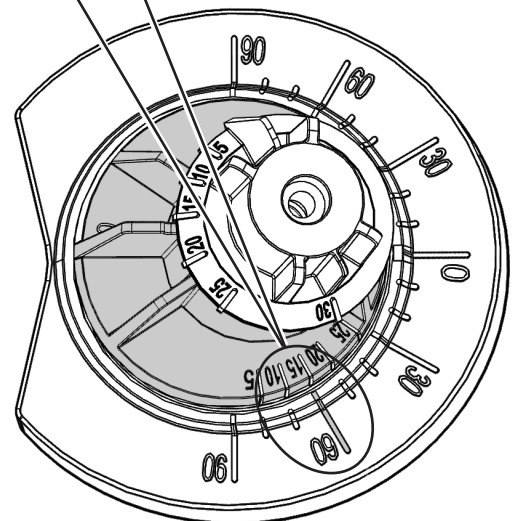
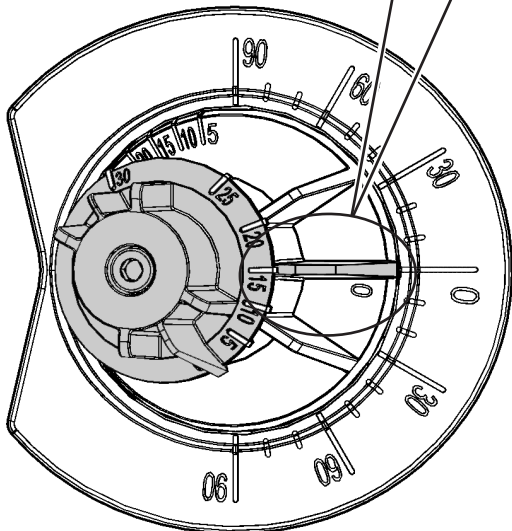
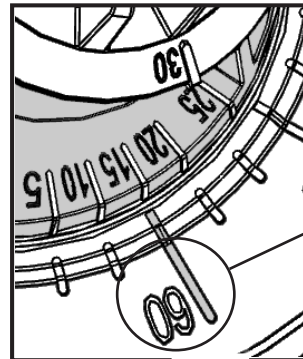

CALCESTRUZZO
CONCRETE
BETON
BETON
CEMENT
HORMIGÓN
BETON
BETONG
BETON
BETOH
混凝土

TERRENO - ROUN
SOL - BODEN
GROND - SUELO
JORD - JORDING
MARK - ПОЧВА - 地面

GHIAIA PER DRENAGGIO
GRAVEL LAYER FOR DRAINAGE
GRAVIER DE DRAINAGE
KIES FÜR DIE DRAINAGE
GRINT VOOR DRAINAGE
GRAVILLA PARA DRENAJE
GRUS TIL DRÆNING
KISLAG FOR TØMMING
DRÆNERINGSGRUS
ДРЕНАЖНЫЙ ГРАВИЙ
排水砂砾层

TUBO PER DRENAGGIO
DRAINAGE PIPE
TUBE DE DRAINAGE
DRAINAGE ROHR
AFVOERBUIS
TUBO PARA DRENAJE
DRÆNRØR
TØMMERØR
DRÆNERINGSRØR
ДРЕНАЖНАЯ ТРУБА
排水管

GHIAIA PER DRENAGGIO
GRAVEL LAYER FOR DRAINAGE
GRAVIER DE DRAINAGE
KIES FÜR DIE DRAINAGE
GRINT VOOR DRAINAGE
GRAVILLA PARA DRENAJE
GRUS TIL DRÆNING
KISLAG FOR TØMMING
DRÆNERINGSGRUS
ДРЕНАЖНЫЙ ГРАВИЙ
排水砂砾层

	DALI (H)
Ø 144mm	220mm
Ø 200mm	240mm
Ø 250mm	280mm

1

2

3 Nm

3

4

3 Nm

art. X197
X203
X209

S

- I Accertarsi che l'area "S" sulla quale poggierà la cornice non presenti sporgenze.
- GB Make sure area "S" onto which the frame will rest is free of any projections.
- F Contrôlez que la zone «S» sur laquelle reposera le cadre ne présente pas d'aspérités.
- D Vergewissern Sie sich, dass der Bereich „S“, also die Stelle, wo der Rahmen aufgelegt wird, keine Unebenheiten aufweist.
- NL Let op dat de zone "S" waarop de lijst zal rusten geen uitsteeksels vertoont.
- E Asegurarse de que el área «S», sobre la que se apoyará el marco, no presente salientes.
- DK Kontroller, at området "S", som kanten støtter mod, ikke rager ud nogen steder.
- N Se til at området "S" der rammene skal hvile er fri for fremspring.
- S Försäkra dig om att det inte finns några utstickande delar på området "S" där ramen vilar.
- RUS Проверьте, чтобы площадь "S", на которую опирается рамка, не имела выступов.
- CN 确保框架放置的"S"区域无任何照射。

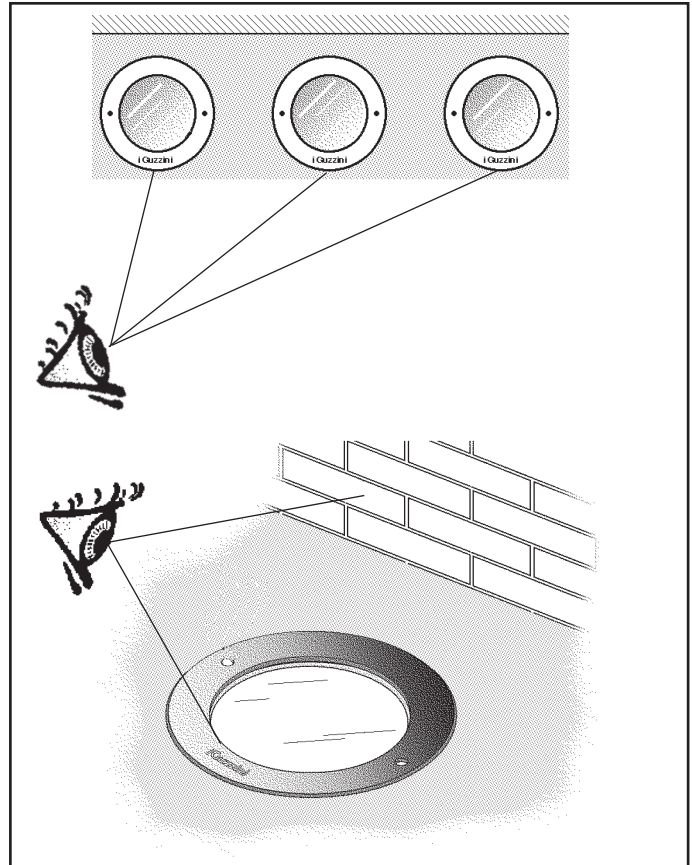

- I Disporre i cavi ai lati dell'apparecchio come indicato in figura.
- GB Arrange the cables on the sides of the luminaire as indicated in the figure.
- F Placez les câbles sur les côtés de l'appareil comme illustré (voir figure).
- D Ordnen Sie die Kabel wie in der Abbildung dargestellt an den Seiten der Leuchte an.
- NL Plaats de kabels aan de zijkanen van het apparaat zoals aangegeven in de afbeelding.
- E Coloque los cables a los costados del aparato como lo indica la figura.
- DK Anbring ledningerne på siderne af armaturet, som vist i figuren.
- N Plasser kablene på siden av lysarmaturen slik som indikert på figuren.
- S Placera kablarna på utrustningens sidor, som visas i figuren.
- RUS Расположите провода по бокам прибора, как показано на схеме.
- CN 如图所示在灯具侧排列电缆。

NO

OK

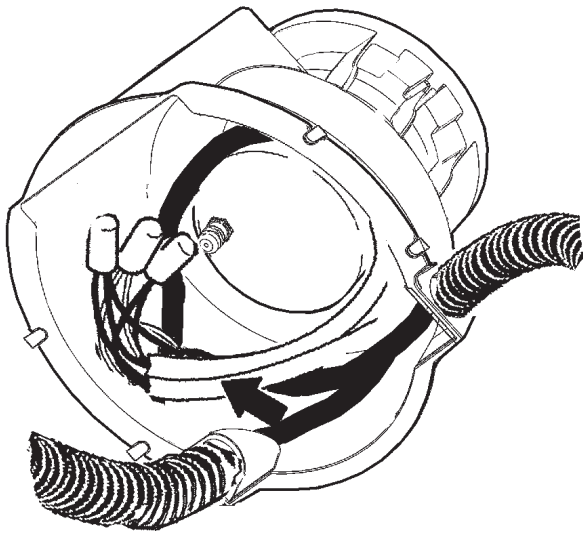

DALI

<p>CARICO DALI / DALI LOAD CHARGE DALI (COURANT MAXI ADMISSIBLE) DALI-LAST DALI VERMOGEN CARGA DALI DALI STRÖMSTYRKE BELASTNING FOR "DALI" DALI-BELASTNING МАКС. ТОК СИСТЕМЫ DALI С РЕГУЛЯЦИЕЙ ИНТЕНСИВНОСТИ СВЕТА DALI 智能调光系统允许的最大电流</p>	<p>INDIRIZZI DALI DALI ADDRESSES ADRESSES DALI DALI-ADRESSEN DALI ADRESSEN DIRECCIONES DALI DALI ADDRESSER ADDRESSER TIL "DALI" DALI-ADDRESSER ЛОГИЧЕСКИЕ АДРЕСА СИСТЕМЫ DALI DALI智能调光系统计算机指定控制参数</p>
<p>1 (2 mA)</p>	<p>1</p>

art. B916

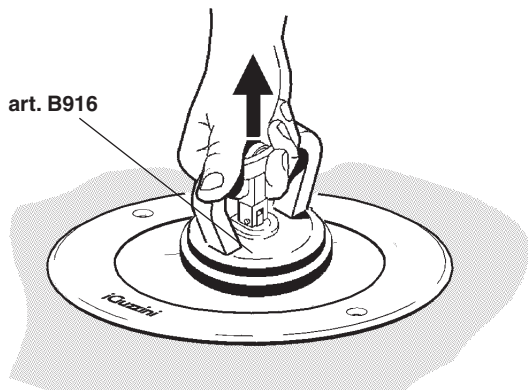

- I N.B.: Per la sostituzione del LED contattare l'azienda iGuzzini.
- GB N.B.: For information on LED replacement please contact iGuzzini.
- F N.B.: Pour procéder au remplacement de la LED, adressez-vous à la société iGuzzini.
- D N.B.: Bezüglich des Austausches der LED kontaktieren Sie bitte die Firma iGuzzini.
- NL N.B.: Voor het vervangen van de LED neemt u contact op met het bedrijf iGuzzini.
- E NOTA: Para sustituir el LED llame a la empresa iGuzzini.
- DK N.B.: For udskiftning af lysdioden, skal man kontakte iGuzzini.
- N N.B.: For informasjon om skifte av LED, vennligst ta kontakt med iGuzzini.
- S OBS! För byte av lysdioden, kontakta företaget iGuzzini.
- RUS ПРИМЕЧАНИЕ: Для замены СИДов обращайтесь в компанию iGuzzini.
- CN 注意：如需LED更换的信息，请联系iGuzzini。

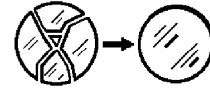

- I In caso di rottura del vetro il prodotto non può essere utilizzato, contattare il costruttore per la sua sostituzione.
- GB Should the glass break, the product cannot be used and you should contact the manufacturer for its replacement.
- F En cas d'endommagement de l'écran de protection le produit ne peut pas être utilisé, contactez le fabricant pour le remplacement.
- D Falls das Glas kaputt sein sollte, kann das Produkt nicht verwendet werden. Kontaktieren Sie in dem Fall den Hersteller, um das Glas zu ersetzen.
- NL Als het glas gebroken is kan het apparaat niet worden gebruikt en moet u zich tot de fabrikant wenden voor het vervangen van het glas.
- E No utilizar el producto en caso de ruptura del vidrio y contactar el fabricante para la sustitución.
- DK Hvis produktets glas ødelægges, kan det ikke anvendes. Kontakt forhandleren med henblik på udskiftning.
- N Hvis glasset skulle knuses, kan ikke produktet brukes, og du må ta kontakt med produsenten for å få det skiftet.
- S Om glaset går sönder kan inte produkten användas. Kontakta tillverkaren för att byta ut glaset.
- RUS В случае разбивания стекла не используйте прибор, обратитесь к его производителю для замены.
- CN 且玻璃破碎后产品将不能再使用，须联系生产商予以更换。

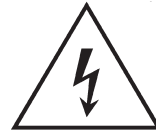

- I Attenzione, rischio di scossa elettrica
- GB Caution, risk of electric shock
- F Attention, risque de choc électrique
- D Achtung, Stromschlaggefahr
- NL Let op, gevaar voor elektrische schok
- E Atención: riesgo de descarga eléctrica
- DK Advarsel: Fare for elektrisk stød
- N Forsiktig! Fare for elektrisk stød
- S Observera, risk för elstöt
- RUS Внимание, риск поражения электрическим током
- CN 小心，触电危险

LIGHT UP EARTH ADJUSTABLE

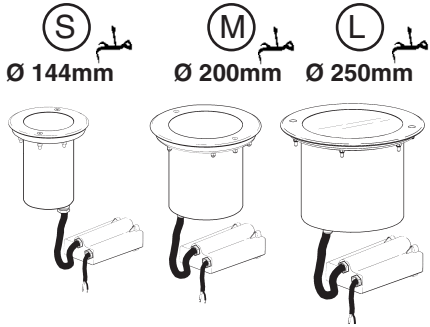

تَحذِير :

لا يمكن ضمان سلامة هذا الجهاز إلا إذا التزمت بهذه التعليمات. يجب حفظها في مكان آمن.

ATTENZIONE:

LA SICUREZZA DELL'APPARECCHIO E' GARANTITA SOLO CON L'USO APPROPRIATO DELLE SEGUENTI ISTRUZIONI; PERTANTO E' NECESSARIO CONSERVARLE.

WARNING:

THE SAFETY OF THIS FIXTURE IS GUARANTEED ONLY IF YOU COMPLY WITH THESE INSTRUCTIONS; REMEMBER TO CONSERVE IN A SAFE PLACE.

ATENCIÓN:

LA SEGURIDAD DEL APARATO SE GARANTIZA SOLO CUMPLIENDO CUIDADOSAMENTE LAS SIGUIENTES INSTRUCCIONES; POR ELLO, ES NECESARIO CONSERVARLAS.

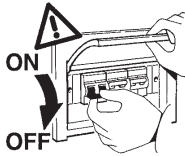

ملاحظة: أجهزة غير قابلة للتغطية بمواد عازلة حرارياً.

- I N.B.: Apparecchi non idonei ad essere coperti di materiale termicamente isolante
- GB N.B.: Fixtures not suitable to be covered in thermally-insulating material.
- E OBS! Utrustningen får inte täckas över med värmeisolerande material



ترتيب الأنابيب المجددة و/أو الكبلات الكهربائية، يجب مراجعة تصميم الجهاز.

- I Per la disposizione dei tubi corrugati e/o dei cavi elettrici, fare riferimento al progetto dell'impianto.
- GB See the system project for the arrangement of the corrugated pipes and/or electric cables.
- E Para la ubicación de los tubos corrugados y/o de los cables eléctricos, hágase referencia al proyecto de la instalación.

ملاحظة: ملاحظة: أثناء تركيب نظام بحرص بالنظم السائدة المتعلقة بالشبكة الكهربائية.

N.B.: DURANTE L'INSTALLAZIONE DEL SISTEMA RISPETTARE SCRUPolosAMENTE LE NORME IMPIANTISTICHE VIGENTI.

N.B.: WHEN INSTALLING THE SYSTEM STRICTLY COMPLY WITH ALL REGULATIONS ON INSTALLATION IN FORCE.

N.B.: DURANTE LA INSTALACIÓN DEL SISTEMA RESPETAR ESCRUPolosAMENTE LAS NORMAS DE INSTALACIÓN VIGENTES.

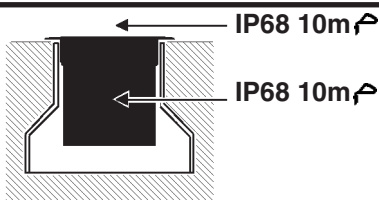

تم تصميم الأجهزة واختبارها لكي تكون قادرة على تحمل حمولة استاتيكية تصل إلى غاية 50000 كغم وبنفس الوقت مقاومة للتأثيرات الناتجة عن عملية التشغيل. التركيب غير مسموح في المناطق التي تمر فيها جرافات الثلج وبسرعة تزيد عن 50 كغم/ساعة.

I Gli apparecchi sono stati progettati e collaudati per reggere un carico statico fino a 50000 N e resistere alle sollecitazioni di percorrenza. L'installazione non è ammessa in zone di utilizzo di spalaneve e con carrabilità a velocità superiori ai 50 Km/h.

GB The lighting fixtures were designed and tested to withstand a static load of up to 50000 N and to resist drive-over stress. The fixtures may not be installed in areas where snowplows are used, or where the drive-over speed exceeds 50 km/h.

E Los aparatos han sido proyectados y probados para soportar una carga estática máxima de 50000 N y resistir a los esfuerzos derivados del tránsito. La instalación no está admitida en zonas donde se utilizan máquinas para espalar la nieve y donde esté permitido el tráfico a velocidades superiores a los 50 Km/h.

أرضية
PAVIMENTO
PAVING
PAVIMENTACIÓN

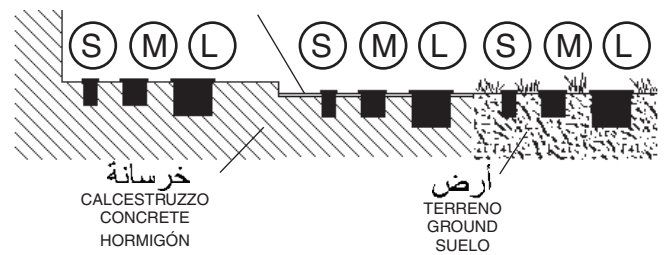

يوصى بتوفير الحماية الكافية للكابل، ومنعه من الاتصال المباشر بالأرض.

- I Si consiglia di proteggere adeguatamente il cavo dal contatto diretto con il terreno.
- GB The cable should be suitably protected against direct contact with the ground.
- E Se recomienda proteger adecuadamente el cable del contacto directo con el terreno.

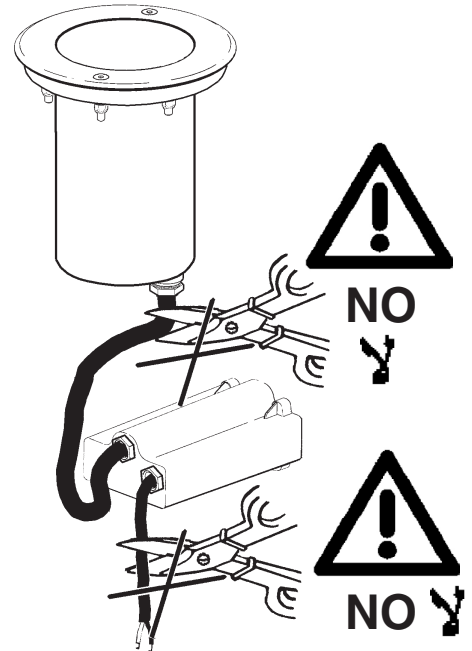

في حال تلف الكبل الخارجي المرص، يجب تغييره من قبل المصنع أو من قبل مركز الخدمة المعنول أو من قبل أحد أعضاء الطاقم الممثلين والمؤهلين وذلك نحاشي إحراق أي خطر.

I In caso di danneggiamento del cavo flessibile esterno, questo deve essere sostituito dal costruttore, o dal suo servizio di assistenza, o da personale qualificato equivalente, al fine di evitare pericoli.

GB Should the outer flexible cable be somehow damage, the latter should be replaced by the manufacturer, or by the corresponding service centre, or by an appropriate and qualified member of staff in order to avoid all risk of danger.

E En caso de daños el cable flexible externo debe substituirse por el fabricante, su servicio de asistencia o personal calificado equivalente para evitar peligros.

(S) (M) (L)

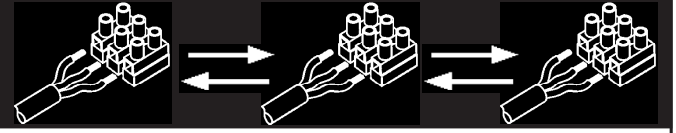
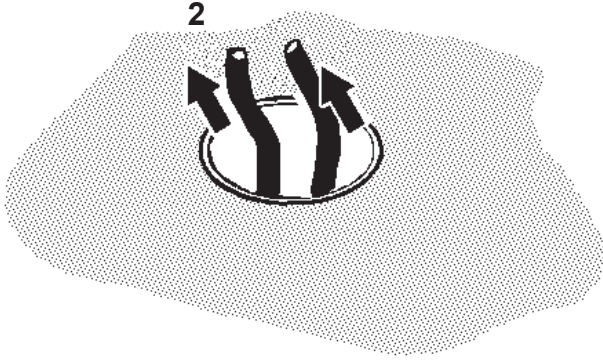
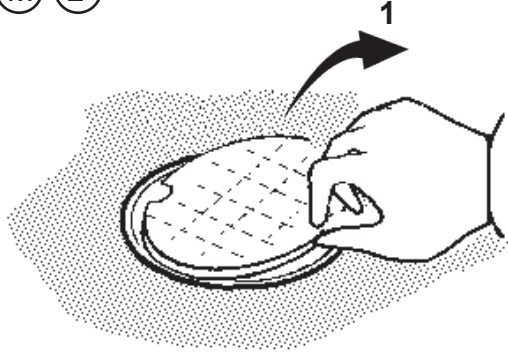

220/240 V

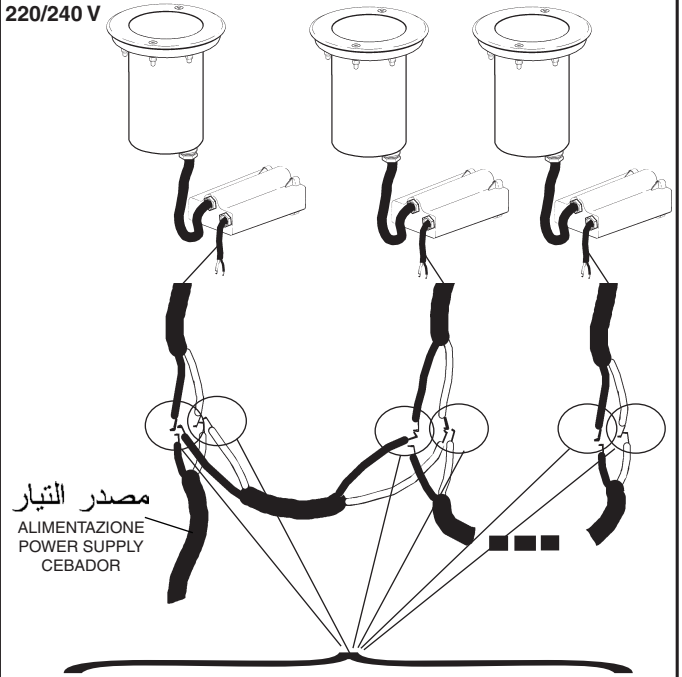

شريط يتكتل بشكل ذاتي

NASTRO AUTOAGGLOMERANTE
SELF-VULCANISING TAPE
CINTA AUTOAGLOMERANTE
(SCOTCH 23 3M)



الصفن
art. 9581

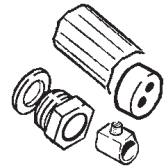

الصفن
art. B915

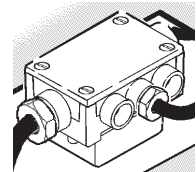

الصفن
art. X189

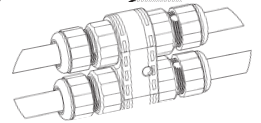

220/240 V

شريط يتكتل بشكل ذاتي

NASTRO AUTOAGGLOMERANTE
SELF-VULCANISING TAPE
CINTA AUTOAGLOMERANTE
(SCOTCH 23 3M)



الصفن
art. 9581

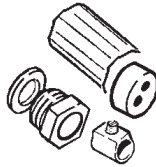

الصفن
art. B915

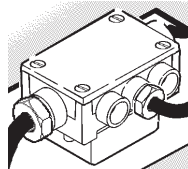

الصفن
art. X188

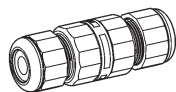

الصفن
art. X189

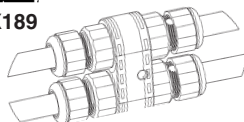

مصدر التيار
ALIMENTAZIONE
POWER SUPPLY
CEBADOR

شريط يتكتل بشكل ذاتي

NASTRO AUTOAGGLOMERANTE
SELF-VULCANISING TAPE
CINTA AUTOAGLOMERANTE
(SCOTCH 23 3M)

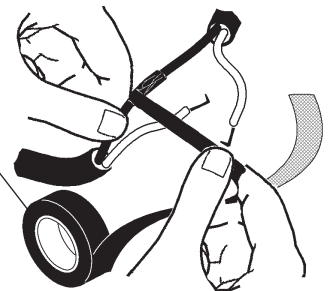



ألحم
STAGNARE
WELD
ESTANAR

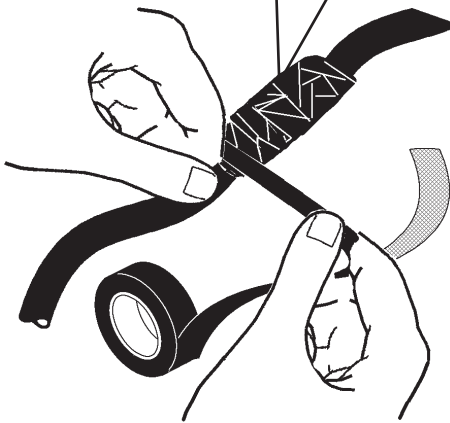
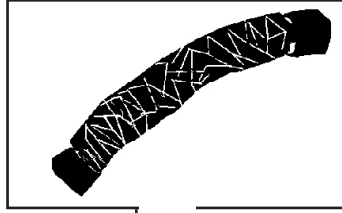
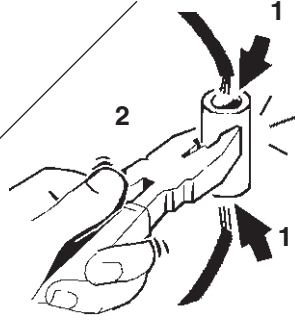

art. 9581

الصنف art. 9581

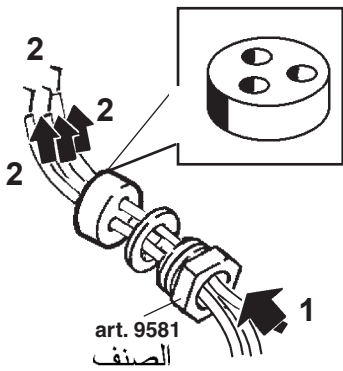
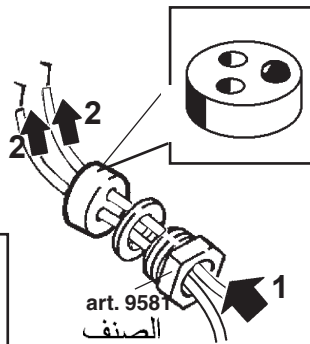
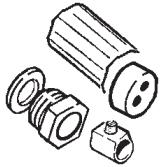

art. 9581
الصنف

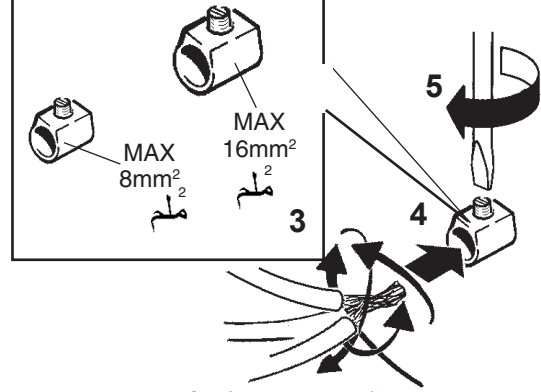
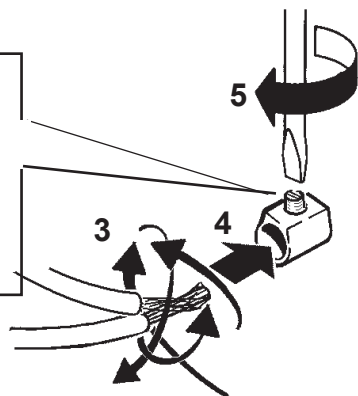
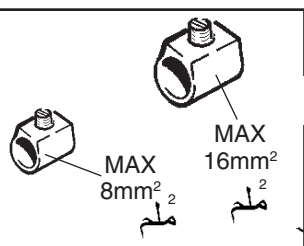

تنبيه: تحقق يدويا من مناعة الكبلات داخل طرف التوصيل.

I N.B.: Verificare manualmente la tenuta dei cavi nel morsetto.
GB N.B.: Manually check the tightness of the cables in the terminal board.
E N.B.: Verificar manualmente la fijación de los cables en el terminal.

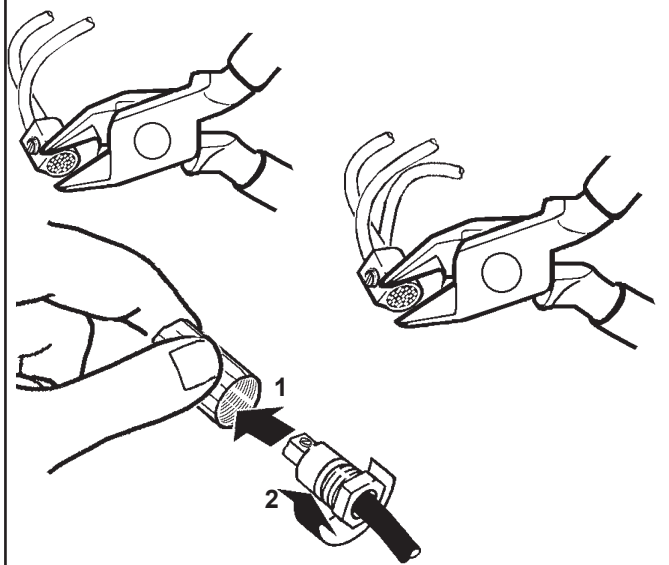

شريط يتكتل بشكل ذاتي

NASTRO AUTOAGGLOMERANTE
SELF-VULCANISING TAPE
CINTA AUTOAGGLOMERANTE
(SCOTCH 23 3M)



art. B915

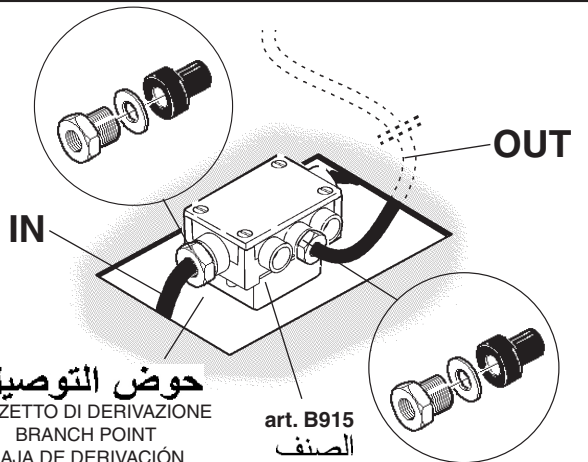

حوض التوصيل

POZZETTO DI DERIVAZIONE
BRANCH POINT
CAJA DE DERIVACIÓN

art. B915
الصنف

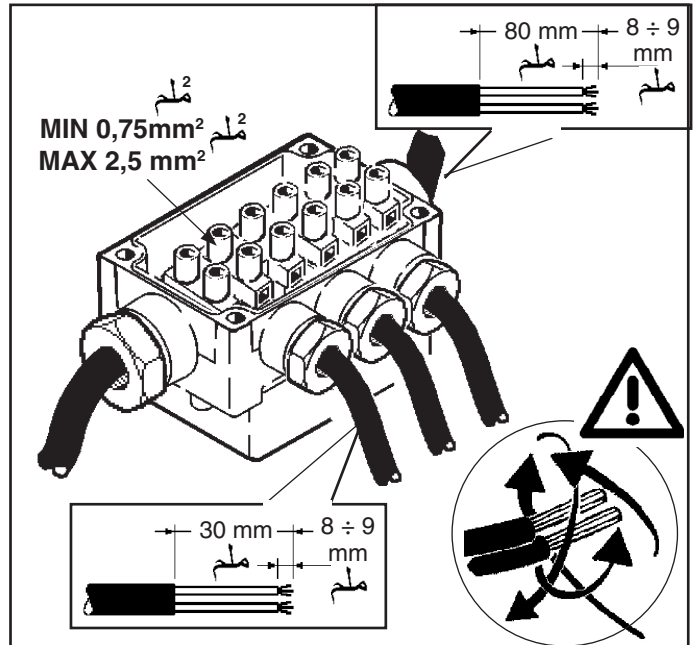
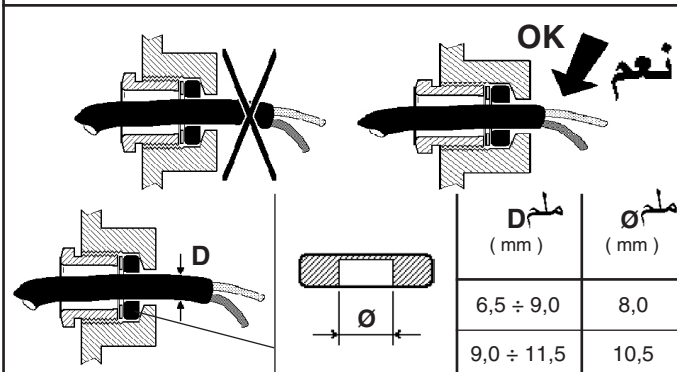
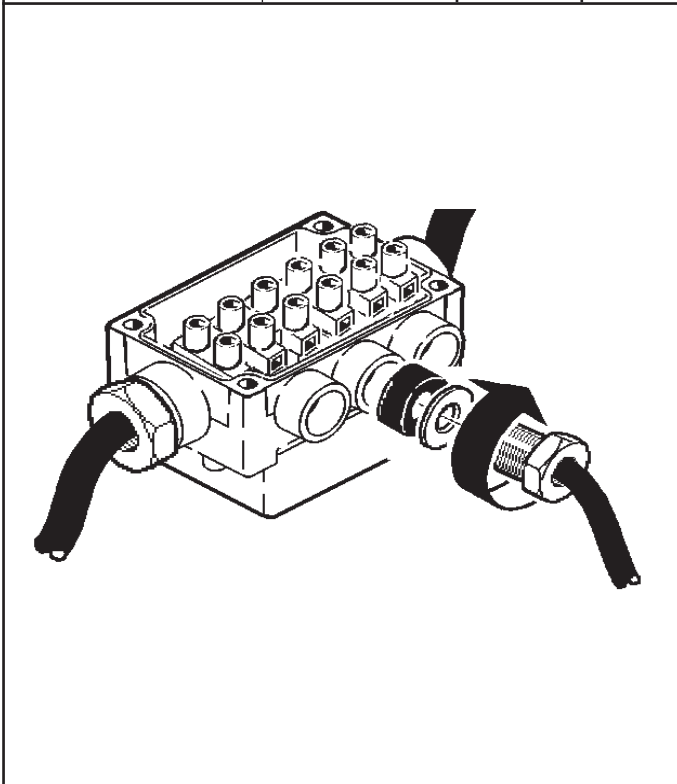
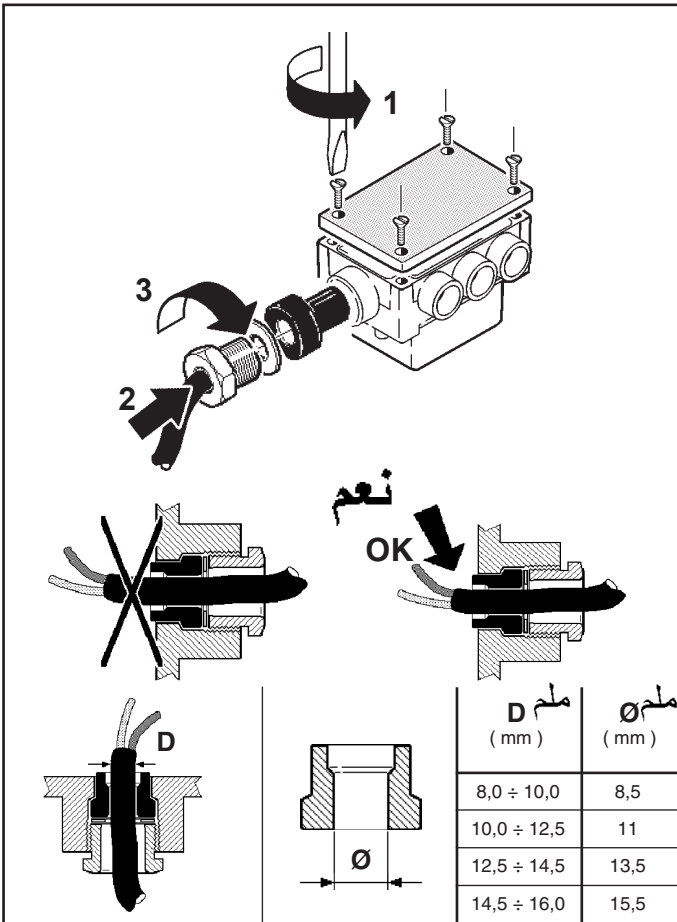

تنبيه: تحقق يدويا من مناعة الكبلات داخل طرف التوصيل. عر

I N.B.: Verificare manualmente la tenuta dei cavi nel morsetto.

GB N.B.: Manually check the tightness of the cables in the terminal board.

E N.B.: Verificar manualmente la fijación de los cables en el terminal.

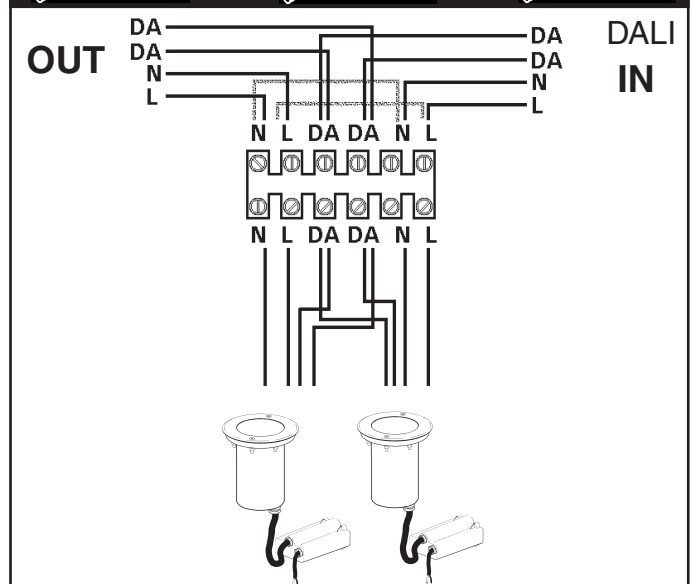
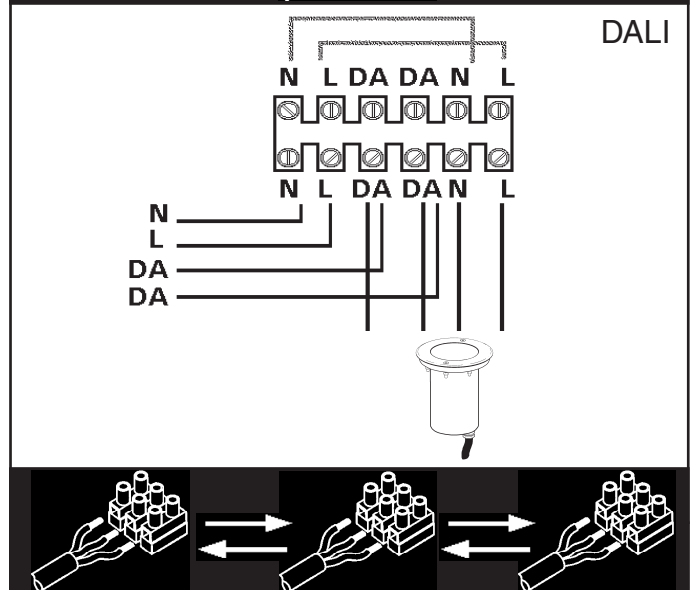
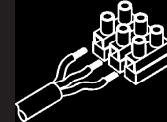

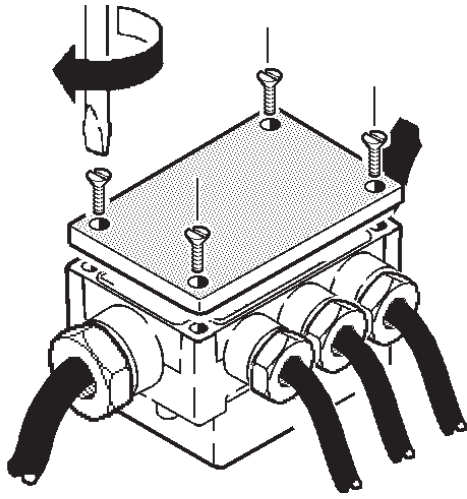

art. X188

الصنف art. X188

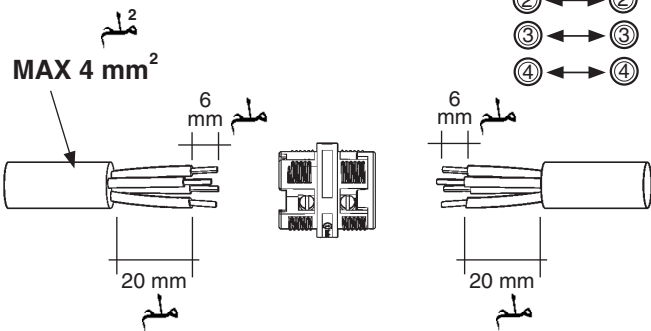
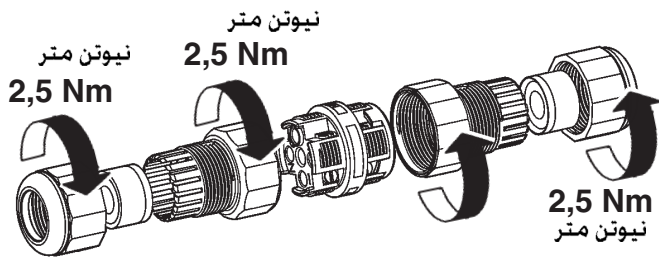
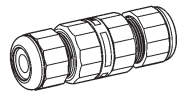

- ① ↔ ①
- ② ↔ ②
- ③ ↔ ③
- ④ ↔ ④

D (mm) ملم	
2,5 ÷ 4,5 ملم	
4,5 ÷ 7 ملم	
7 ÷ 9 ملم	
9 ÷ 12 ملم	

art. X189

الصنف art. X189

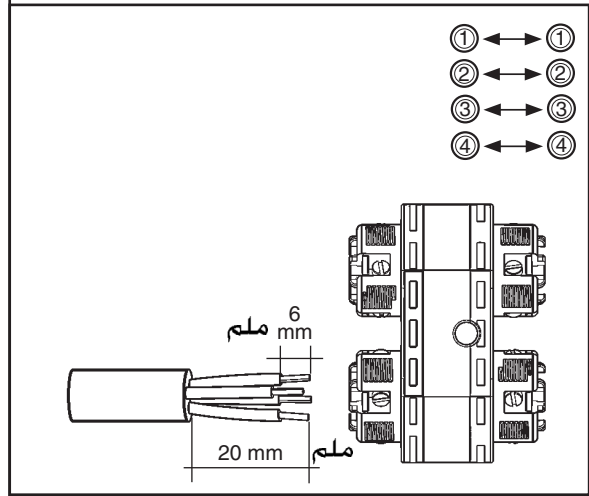
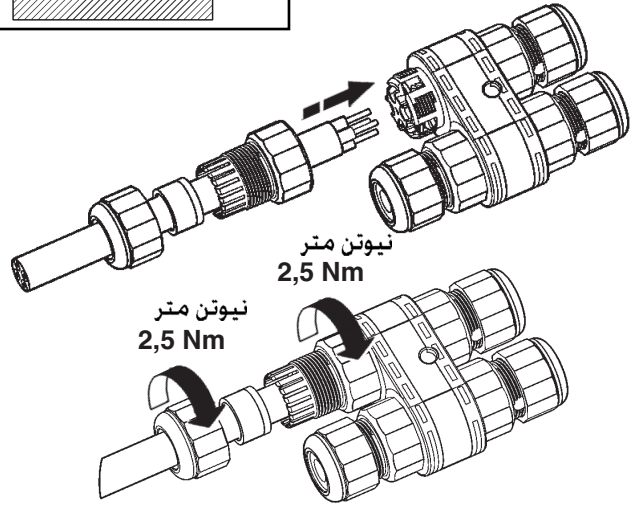
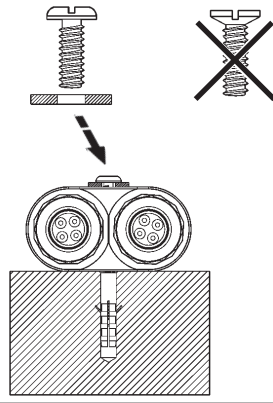

D (mm) ملم	
2,5 ÷ 4,5 ملم	
4,5 ÷ 7 ملم	
7 ÷ 9 ملم	
9 ÷ 12 ملم	

ضبط موضع مجموعة العدسة

ORIENTAMENTO DEL VANO OTTICO
ADJUSTING THE POSITION OF THE OPTICAL ASSEMBLY
ORIENTABILIDAD DE LA OPTICA

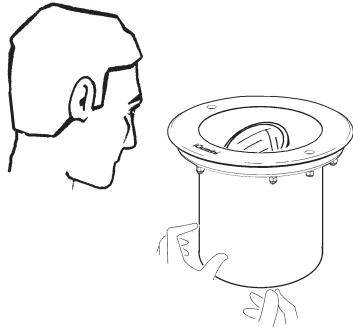

α

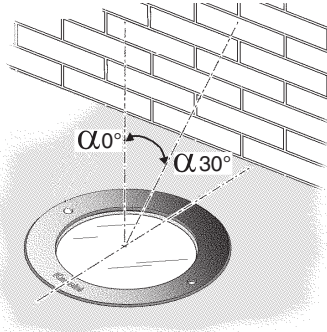

γ

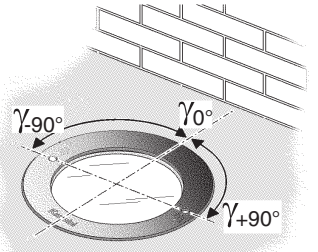

$\alpha = 0^\circ$
 $\gamma = 0^\circ$

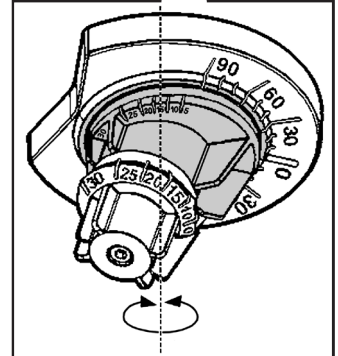
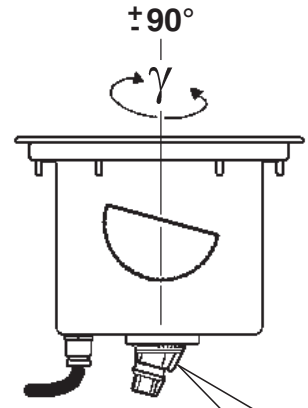
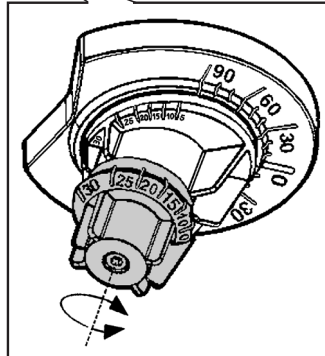
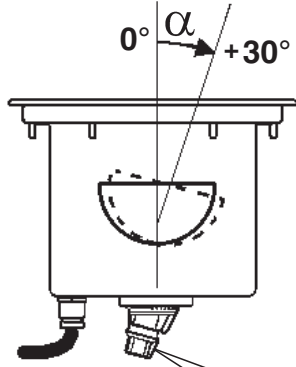
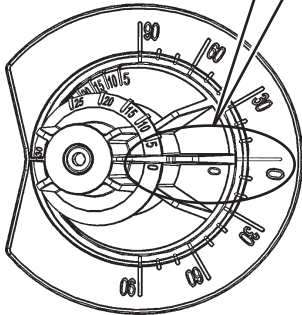
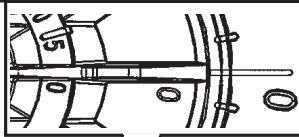

مثال ESEMPIO - EXAMPLE - EJEMPLO

$\alpha = 30^\circ$
 $\gamma = 0^\circ$

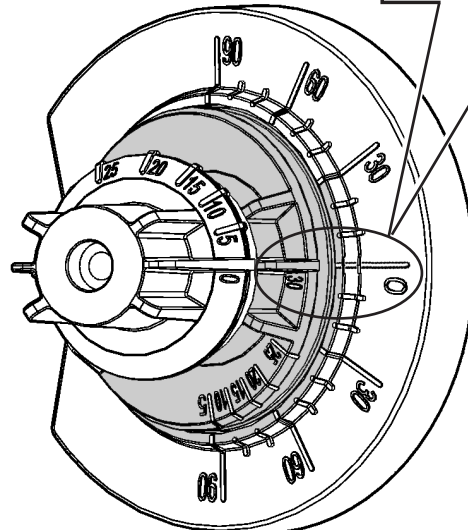
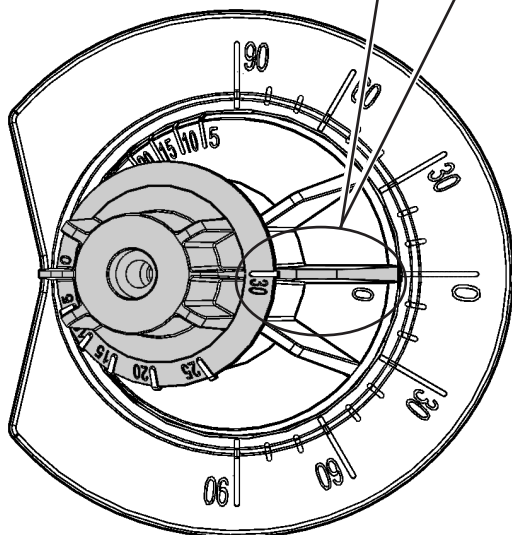
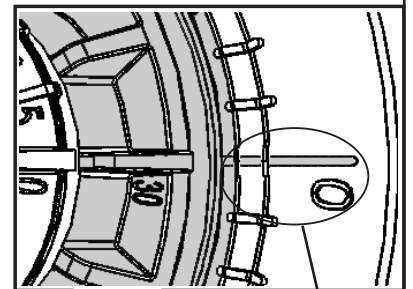
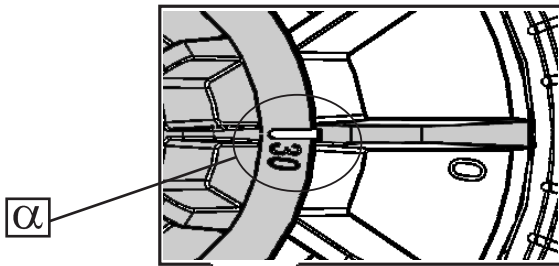

$\alpha = 15^\circ$
 $\gamma = 0^\circ$

α

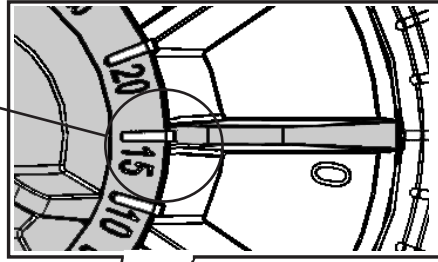

γ

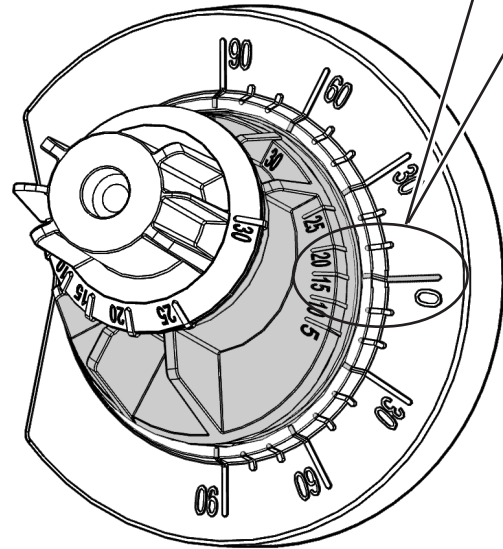
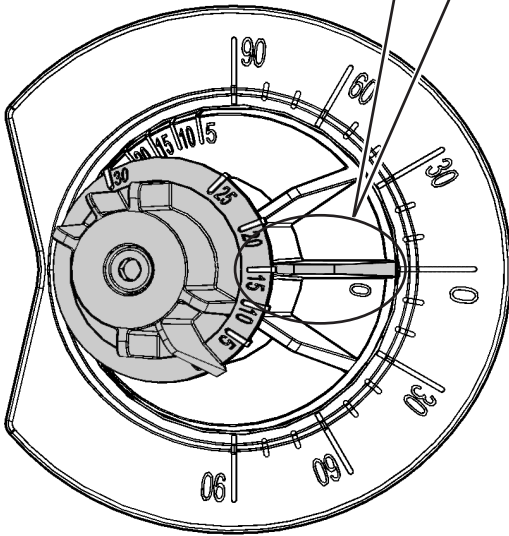
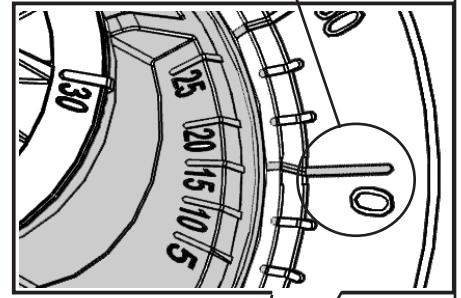

$\alpha = 15^\circ$
 $\gamma = 60^\circ$

α

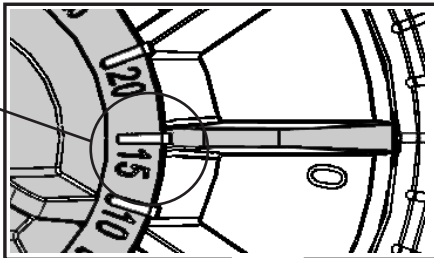

γ

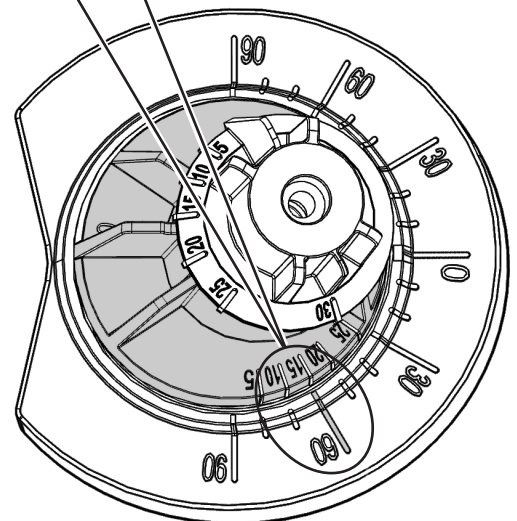
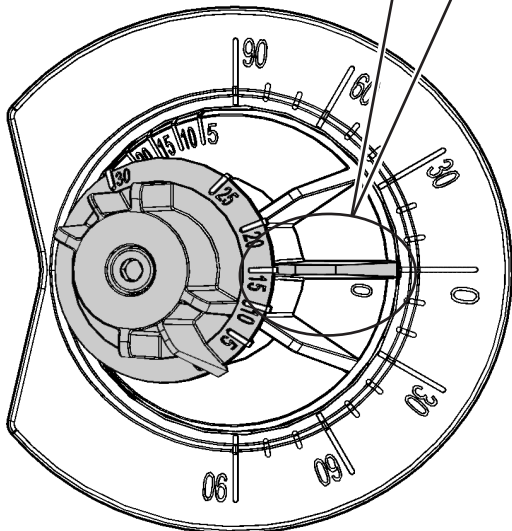
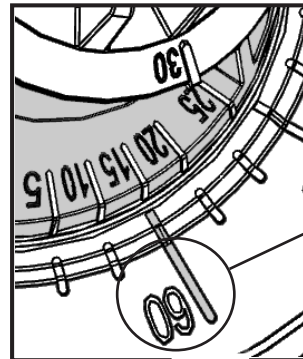

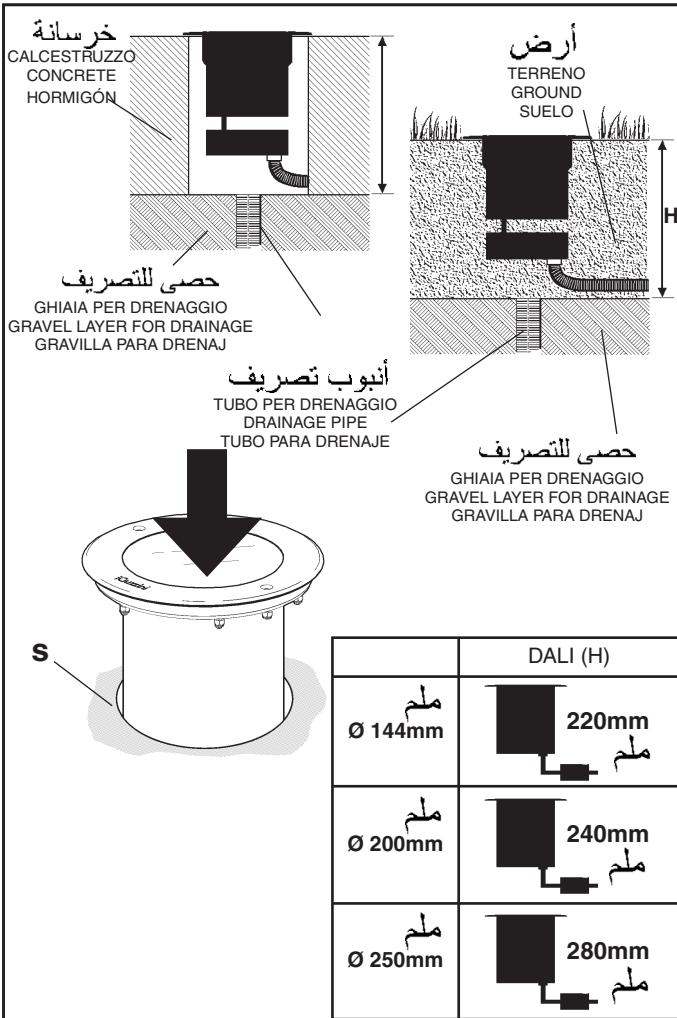

تحقق من أن المساحة "S" التي يرتكز عليها الإطار لا توجد لها أطراف متدلية.

I Accertarsi che l'area "S" sulla quale poggierà la cornice non presenti sporgenze.

GB Make sure area "S" onto which the frame will rest is free of any projections.

E Asegurarse de que el área "S", sobre la que se apoyará el marco, no presente salientes.

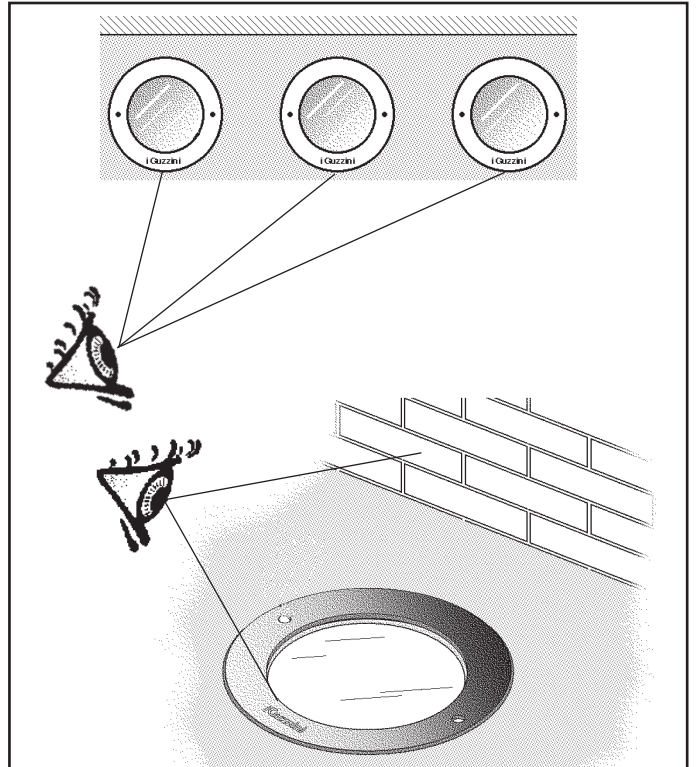

عر ضع الكبلات على جوانب الجهاز كما هو مبين في الشكل.

I Disporre i cavi ai lati dell'apparecchio come indicato in figura.

GB Arrange the cables on the sides of the luminaire as indicated in the figure.

E Coloque los cables a los costados del aparato como lo indica la figura.

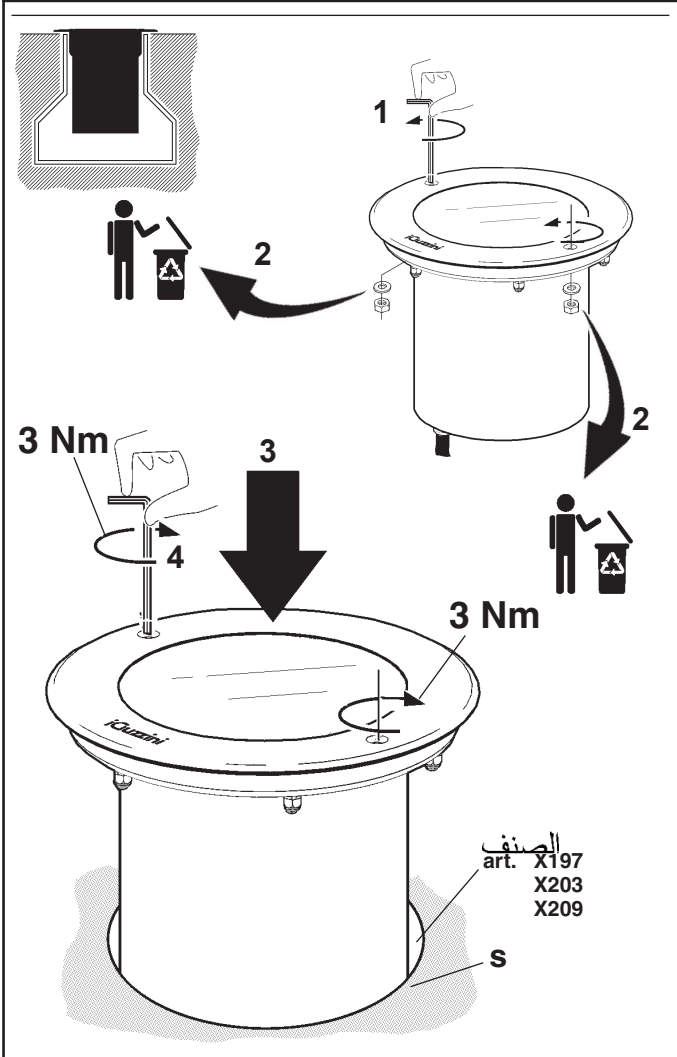
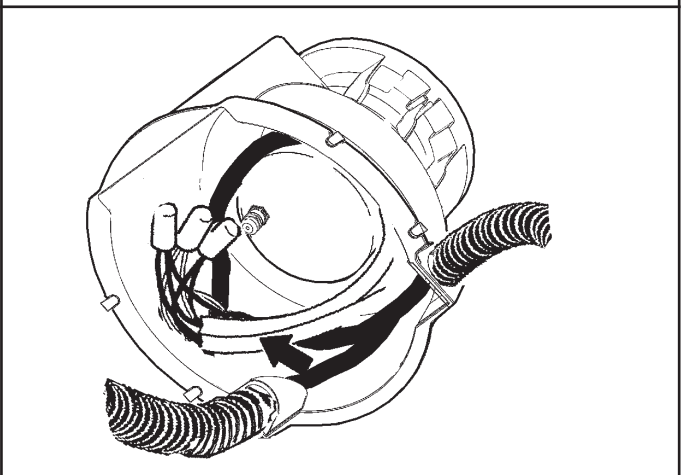
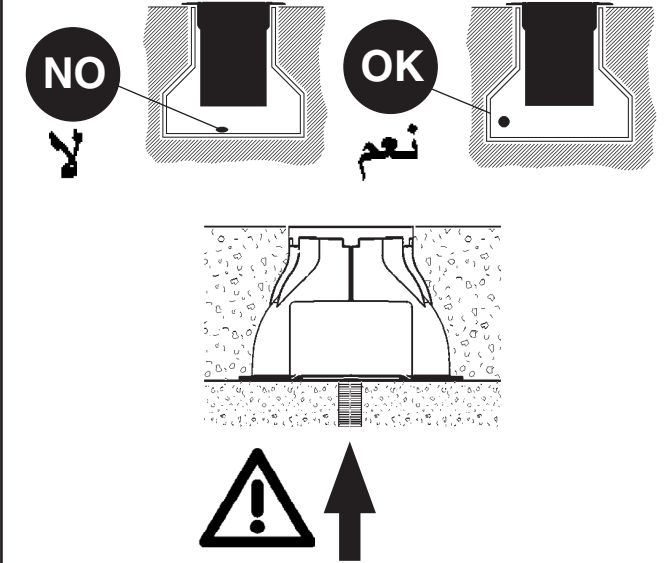

DALI

<p>شحنة DALI / حمل DALI CARICO DALI / DALI LOAD CHARGE DALI CARGA DALI</p>	<p>عناوين DALI INDIRIZZI DALI DALI ADDRESSES DIRECCIONES DALI</p>
1 (2 mA)	1

art. B916

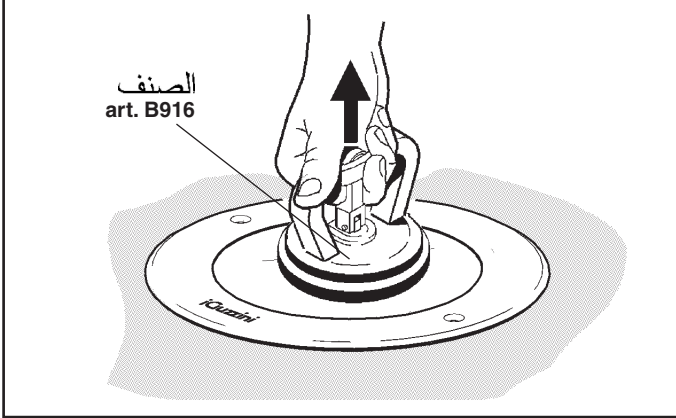

تنبيه: لاستبدال الضوء LED اتصل بشركة iGuzzini . عر

I N.B.: Per la sostituzione del LED contattare l'azienda iGuzzini.

GB N.B.: For information on LED replacement please contact iGuzzini.

E NOTA: Para sustituir el LED llame a la empresa iGuzzini.

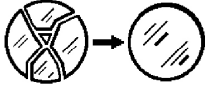

لا يمكن استعمال المنتج في حالة كسر الزجاج، وبالتالي يجب الاتصال بالصانع لاستبداله. عر

I In caso di rottura del vetro il prodotto non può essere utilizzato, contattare il costruttore per la sua sostituzione.

GB Should the glass break, the product cannot be used and you should contact the manufacturer for its replacement.

E No utilizar el producto en caso de ruptura del vidrio y contactar el fabricante para la sustitución.

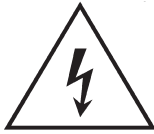

تنبيه، خطر الصدمة الكهربائية عر

I Attenzione, rischio di scossa elettrica

GB Caution, risk of electric shock

E Atención: riesgo de descarga eléctrica

2.510.101.03 IS11090/03	iGuzzini	corrente assorbita absorbed current courant absorbé Stromaufnahme stromopname corriente absorbida absorberet strøm absorbirt strøm tillförd ström поглощаемая мощность 电源电流	fattore di potenza power factor facteur de puissance Leistungsfaktor vermogensfactor factor de potencia effektfaktor effektfaktor effektfaktor фактор мощности 功率因数
ART.	A	λ	
E127 - E132 - E141- E145 E149 - E154 - E169 - E173	0,05	0,93	
E170 - E171 - E172 E174 - E175 - E176	0,08	0,86	
E128 - E133 - E139 - E140	0,07	0,94	
E142 - E143 - E144 - E146 E147 - E148	0,06	0,93	
E129 - E130 - E131 - E134 E135 - E136 - E150 - E155 E161 - E162	0,06	0,95	
E112 - E113 - E114 - E116 E117 - E118	0,06	0,83	
E151 - E152 - E153 - E156 E157 - E158	0,1	0,9	
E111 - E115 - E121 - E122	0,04	0,9	
E123 - E124	0,03	0,84	
E125 - E126 - E292 - E293	0,04	0,93	
BW00 - BW01 - BW02 BW03 - BW04 - BW05	0,05	0,88	
E163 - E164 - E165 E166 - E167 - E168	0,15	0,94	
E119 - E120 - BV84 - BV85	0,06	0,89	
E137 - E138 - BV86 - BV87	0,08	0,96	
E159 - E160 - BV88 - BV89	0,11	0,9	
E111 - E112 - E113 - E114 E115 - E116	0,21	0,95	

2.510.101.03 IS11090/03	iGuzzini	corrente assorbita absorbed current courant absorbé Stromaufnahme stromopname corriente absorbida absorberet strøm absorbirt strøm tillförd ström поглощаемая мощность 电源电流	fattore di potenza power factor facteur de puissance Leistungsfaktor vermogensfactor factor de potencia effektfaktor effektfaktor effektfaktor фактор мощности 功率因数
ART.	A	λ	
E127 - E132 - E141- E145 E149 - E154 - E169 - E173	0,05	0,93	
E170 - E171 - E172 E174 - E175 - E176	0,08	0,86	
E128 - E133 - E139 - E140	0,07	0,94	
E142 - E143 - E144 - E146 E147 - E148	0,06	0,93	
E129 - E130 - E131 - E134 E135 - E136 - E150 - E155 E161 - E162	0,06	0,95	
E112 - E113 - E114 - E116 E117 - E118	0,06	0,83	
E151 - E152 - E153 - E156 E157 - E158	0,1	0,9	
E111 - E115 - E121 - E122	0,04	0,9	
E123 - E124	0,03	0,84	
E125 - E126 - E292 - E293	0,04	0,93	
BW00 - BW01 - BW02 BW03 - BW04 - BW05	0,05	0,88	
E163 - E164 - E165 E166 - E167 - E168	0,15	0,94	
E119 - E120 - BV84 - BV85	0,06	0,89	
E137 - E138 - BV86 - BV87	0,08	0,96	
E159 - E160 - BV88 - BV89	0,11	0,9	
E111 - E112 - E113 - E114 E115 - E116	0,21	0,95	

2.510.101.03 IS11090/03	iGuzzini	corrente assorbita absorbed current courant absorbé Stromaufnahme stromopname corriente absorbida absorberet strøm absorbirt strøm tillförd ström поглощаемая мощность 电源电流	fattore di potenza power factor facteur de puissance Leistungsfaktor vermogensfactor factor de potencia effektfaktor effektfaktor effektfaktor фактор мощности 功率因数
ART.	A	λ	
E127 - E132 - E141- E145 E149 - E154 - E169 - E173	0,05	0,93	
E170 - E171 - E172 E174 - E175 - E176	0,08	0,86	
E128 - E133 - E139 - E140	0,07	0,94	
E142 - E143 - E144 - E146 E147 - E148	0,06	0,93	
E129 - E130 - E131 - E134 E135 - E136 - E150 - E155 E161 - E162	0,06	0,95	
E112 - E113 - E114 - E116 E117 - E118	0,06	0,83	
E151 - E152 - E153 - E156 E157 - E158	0,1	0,9	
E111 - E115 - E121 - E122	0,04	0,9	
E123 - E124	0,03	0,84	
E125 - E126 - E292 - E293	0,04	0,93	
BW00 - BW01 - BW02 BW03 - BW04 - BW05	0,05	0,88	
E163 - E164 - E165 E166 - E167 - E168	0,15	0,94	
E119 - E120 - BV84 - BV85	0,06	0,89	
E137 - E138 - BV86 - BV87	0,08	0,96	
E159 - E160 - BV88 - BV89	0,11	0,9	
E111 - E112 - E113 - E114 E115 - E116	0,21	0,95	

2.510.101.03 IS11090/03	iGuzzini	corrente assorbita absorbed current courant absorbé Stromaufnahme stromopname corriente absorbida absorberet strøm absorbirt strøm tillförd ström поглощаемая мощность 电源电流	fattore di potenza power factor facteur de puissance Leistungsfaktor vermogensfactor factor de potencia effektfaktor effektfaktor effektfaktor фактор мощности 功率因数
ART.	A	λ	
E127 - E132 - E141- E145 E149 - E154 - E169 - E173	0,05	0,93	
E170 - E171 - E172 E174 - E175 - E176	0,08	0,86	
E128 - E133 - E139 - E140	0,07	0,94	
E142 - E143 - E144 - E146 E147 - E148	0,06	0,93	
E129 - E130 - E131 - E134 E135 - E136 - E150 - E155 E161 - E162	0,06	0,95	
E112 - E113 - E114 - E116 E117 - E118	0,06	0,83	
E151 - E152 - E153 - E156 E157 - E158	0,1	0,9	
E111 - E115 - E121 - E122	0,04	0,9	
E123 - E124	0,03	0,84	
E125 - E126 - E292 - E293	0,04	0,93	
BW00 - BW01 - BW02 BW03 - BW04 - BW05	0,05	0,88	
E163 - E164 - E165 E166 - E167 - E168	0,15	0,94	
E119 - E120 - BV84 - BV85	0,06	0,89	
E137 - E138 - BV86 - BV87	0,08	0,96	
E159 - E160 - BV88 - BV89	0,11	0,9	
E111 - E112 - E113 - E114 E115 - E116	0,21	0,95	

PRODUCT ADJUSTING



iGuzzini

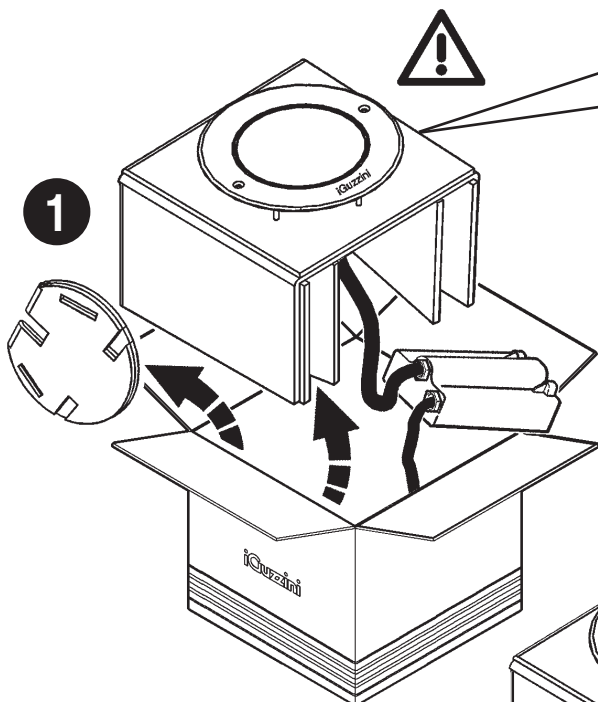

- I Estrarre il prodotto dall'imballo assieme alla parte interna in cartone, lasciandolo nella sua posizione originale come in figura.
- GB Remove the product from the package together with the inner cardboard part, leaving it in its original position as shown in the picture.
- F Extraire le produit de l'emballage avec la partie interne en carton, en le laissant dans sa position originale comme indiqué dans la figure.
- D Das Gerät zusammen mit seinem Pappe-Innenteil aus der Verpackung nehmen, ohne dass das Innenteil verrutscht (siehe die Abbildung).
- NL Neem het product samen met het kartonnen binnengedeelte uit de verpakking en laat het in zijn originele positie zoals aangegeven in de afbeelding.
- E Extraer el producto del embalaje junto con la parte interna de cartón, dejándolo en su posición original como en la figura.
- DK Tag produktet ud af emballagen sammen med den indvendige del i pap, og efterlad det i sin oprindelige position som vist i figuren.
- N Ta produktet ut av emballasjen sammen med den innvendige pappdelen og plasser den i den opprinnelige stillingen som vist i figuren.
- S Ta ut produkten ur emballaget tillsammans med den invändiga kartongdelen och låt den vara i sitt originalläge enligt figuren.
- RUS Извлеките товар из упаковки вместе с внутренней картонной частью, оставляя его в исходном положении, как показано на рисунке.
- CN 从包装中取出产品以及纸盒内的其它部分，按照图示将产品放置在其原始位置。

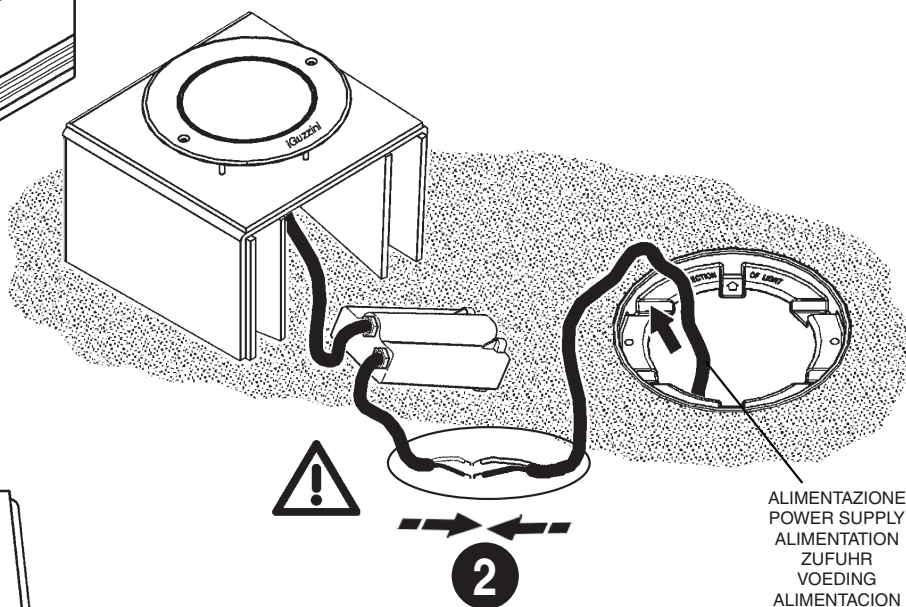

ALIMENTAZIONE
POWER SUPPLY
ALIMENTATION
ZUFUHR
VOEDING
ALIMENTACION
STRØMFORSYNING
STRØMFORSYNING
ELFÖRSÖRJNING
ЭЛЕКТРОПИТАНИЕ
电源

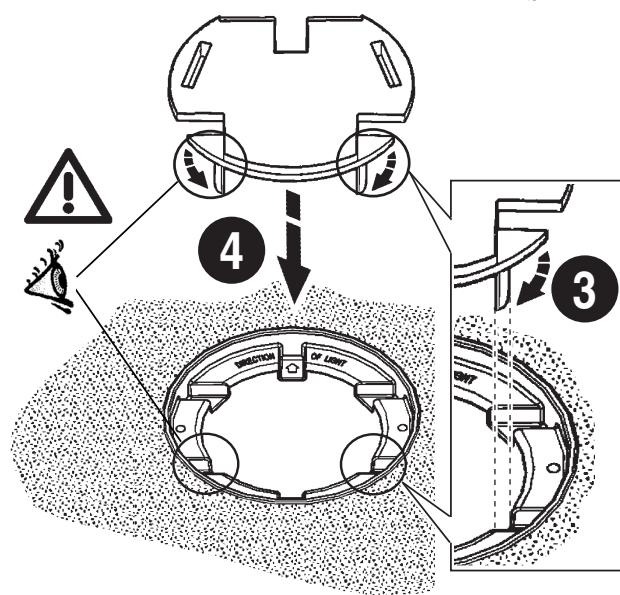
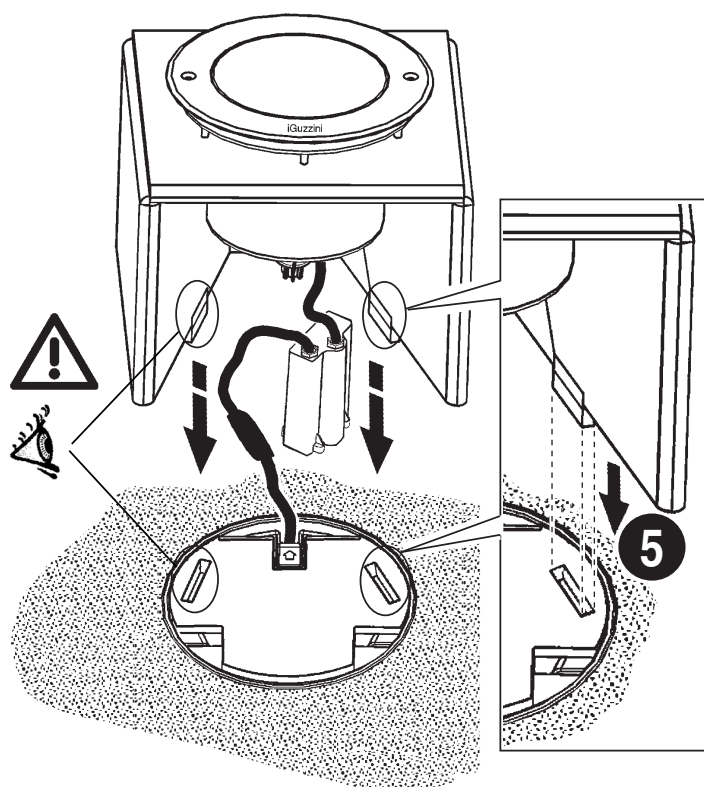

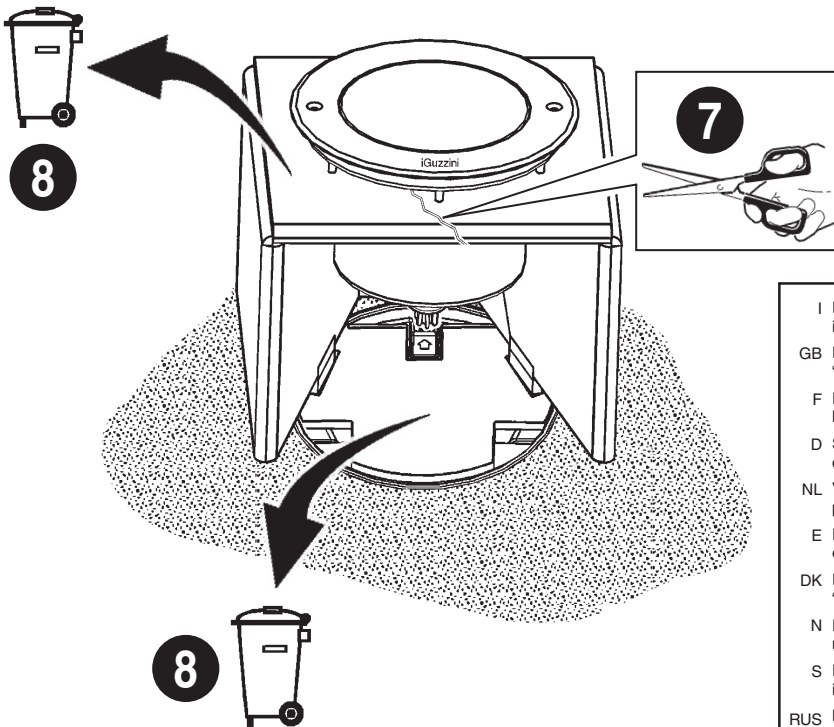
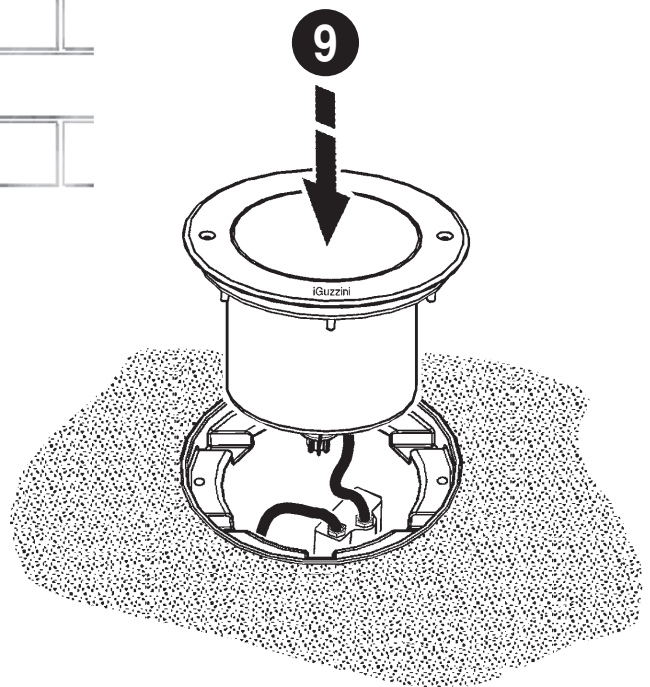
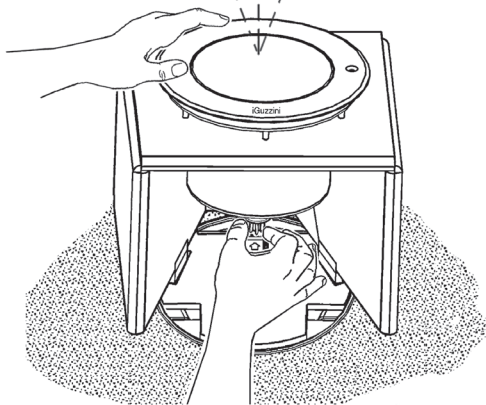
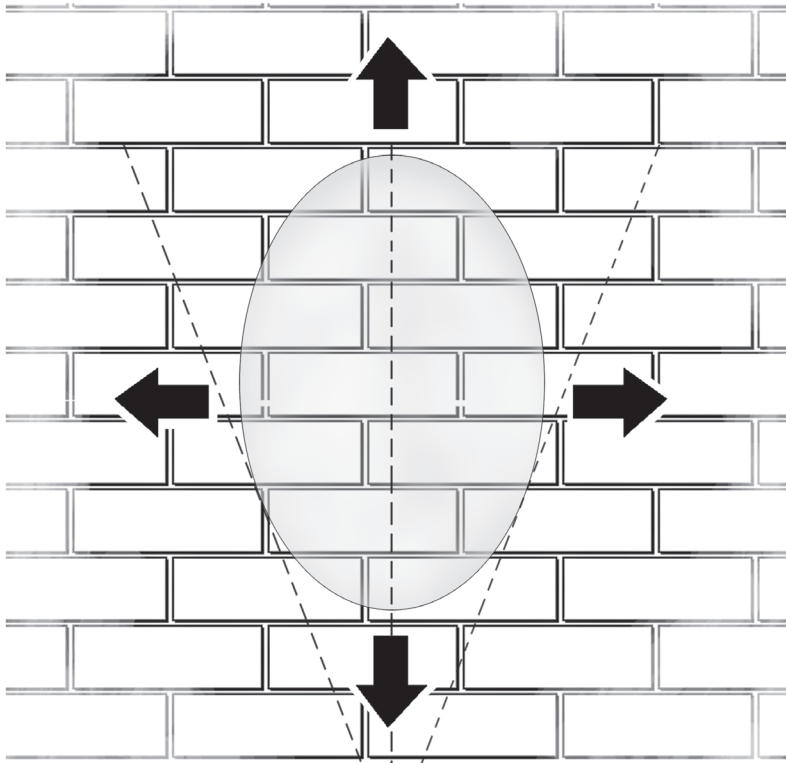

I Per tutte le altre informazioni consultare il foglio istruzioni del prodotto e il sito "iGuzzini".

GB For any other information consult the product's instruction sheet and the "iGuzzini" website.

F Pour toute information supplémentaire, consulter la notice du produit et le site « iGuzzini ».

D Sämtliche weiteren Informationen finden Sie in der Gebrauchsanleitung des Geräts und auf der Webseite der Fa. Gabelzinken.

NL Voor alle andere informatie verwijzen we naar het instructieblad van het product en de website van "iGuzzini".

E Para más información consultar la hoja de instrucciones del producto y el sitio "iGuzzini".

DK For alle andre oplysninger henvises til produktets brugsanvisning og "iGuzzini"-hjemmesiden.

N For ytterligere informasjon, se produktets instruksjonshefte eller besøk nettstedet "iGuzzini".

S För all annan information hänvisas till produktens instruktionsblad och iGuzzini's webbsida.

RUS Всю дополнительную информацию можно найти на иллюстративном вкладыше с инструкциями к товару и на сайте "iGuzzini".

CN 关于其它所有相关信息，请参考产品说明书以及"iGuzzini"网站。

I PERIODO GIORNALIERO DI ACCENSIONE AMMESSO
GB ALLOWED DAILY OPERATION PERIOD
F DURÉE QUOTIDIENNE D'ALLUMAGE ADMISSIBLE
D ERLAUBTE TÄGLICHE EINSCHALTDAUER
NL DAGELIJKSE ONTSTEKINGSPERIODE TOEGESTAAN
E PERIODO DIARIO DE ENCENDIDO PERMITIDO
DK TILLADT TIDSRUM FOR DAGLIG TÆNDING
N TILLÄTT TENNINGSTID PR. DAG
S TILLÄTEN DAGLIG PERIOD SOM PRODUKTEN KAN VARA TÄND
RUS ЕЖЕДНЕВНАЯ ДОПУСТИМАЯ ПРОДОЛЖИТЕЛЬНОСТЬ РАБОТЫ
CN 允许的 日常运营周期

iGuzzini

1.154.627.01
IS09175/01



I PERIODO GIORNALIERO DI ACCENSIONE AMMESSO
GB ALLOWED DAILY OPERATION PERIOD
F DURÉE QUOTIDIENNE D'ALLUMAGE ADMISSIBLE
D ERLAUBTE TÄGLICHE EINSCHALTDAUER
NL DAGELIJKSE ONTSTEKINGSPERIODE TOEGESTAAN
E PERIODO DIARIO DE ENCENDIDO PERMITIDO
DK TILLADT TIDSRUM FOR DAGLIG TÆNDING
N TILLÄTT TENNINGSTID PR. DAG
S TILLÄTEN DAGLIG PERIOD SOM PRODUKTEN KAN VARA TÄND
RUS ЕЖЕДНЕВНАЯ ДОПУСТИМАЯ ПРОДОЛЖИТЕЛЬНОСТЬ РАБОТЫ
CN 允许的 日常运营周期

iGuzzini

1.154.627.01
IS09175/01



I PERIODO GIORNALIERO DI ACCENSIONE AMMESSO
GB ALLOWED DAILY OPERATION PERIOD
F DURÉE QUOTIDIENNE D'ALLUMAGE ADMISSIBLE
D ERLAUBTE TÄGLICHE EINSCHALTDAUER
NL DAGELIJKSE ONTSTEKINGSPERIODE TOEGESTAAN
E PERIODO DIARIO DE ENCENDIDO PERMITIDO
DK TILLADT TIDSRUM FOR DAGLIG TÆNDING
N TILLÄTT TENNINGSTID PR. DAG
S TILLÄTEN DAGLIG PERIOD SOM PRODUKTEN KAN VARA TÄND
RUS ЕЖЕДНЕВНАЯ ДОПУСТИМАЯ ПРОДОЛЖИТЕЛЬНОСТЬ РАБОТЫ
CN 允许的 日常运营周期

iGuzzini

1.154.627.01
IS09175/01



I PERIODO GIORNALIERO DI ACCENSIONE AMMESSO
GB ALLOWED DAILY OPERATION PERIOD
F DURÉE QUOTIDIENNE D'ALLUMAGE ADMISSIBLE
D ERLAUBTE TÄGLICHE EINSCHALTDAUER
NL DAGELIJKSE ONTSTEKINGSPERIODE TOEGESTAAN
E PERIODO DIARIO DE ENCENDIDO PERMITIDO
DK TILLADT TIDSRUM FOR DAGLIG TÆNDING
N TILLÄTT TENNINGSTID PR. DAG
S TILLÄTEN DAGLIG PERIOD SOM PRODUKTEN KAN VARA TÄND
RUS ЕЖЕДНЕВНАЯ ДОПУСТИМАЯ ПРОДОЛЖИТЕЛЬНОСТЬ РАБОТЫ
CN 允许的 日常运营周期

iGuzzini

1.154.627.01
IS09175/01



iGuzzini

2.509.386.00
ISO9176/01

الفترة الزمنية اليومية للتشغيل المسموح بها

- I PERIODO GIORNALIERO DI ACCENSIONE AMMESSO
- GB ALLOWED DAILY OPERATION PERIOD
- E PERIODO DIARIO DE ENCENDIDO PERMITIDO

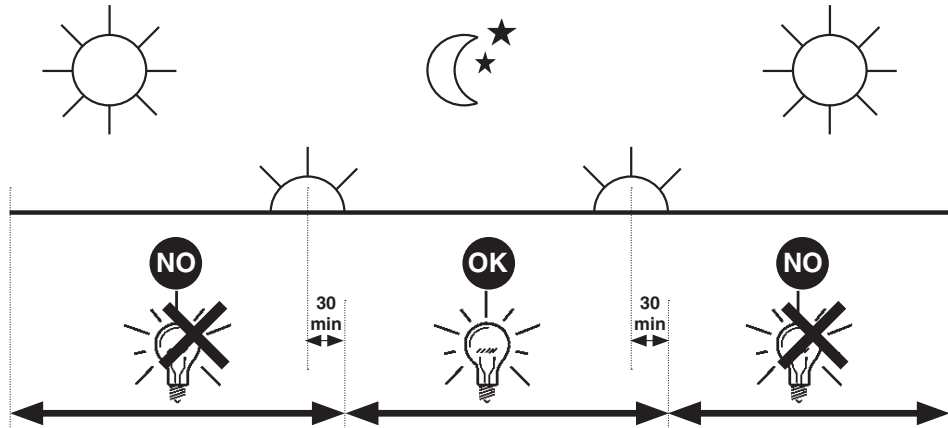

iGuzzini

2.509.386.00
ISO9176/01

الفترة الزمنية اليومية للتشغيل المسموح بها

- I PERIODO GIORNALIERO DI ACCENSIONE AMMESSO
- GB ALLOWED DAILY OPERATION PERIOD
- E PERIODO DIARIO DE ENCENDIDO PERMITIDO

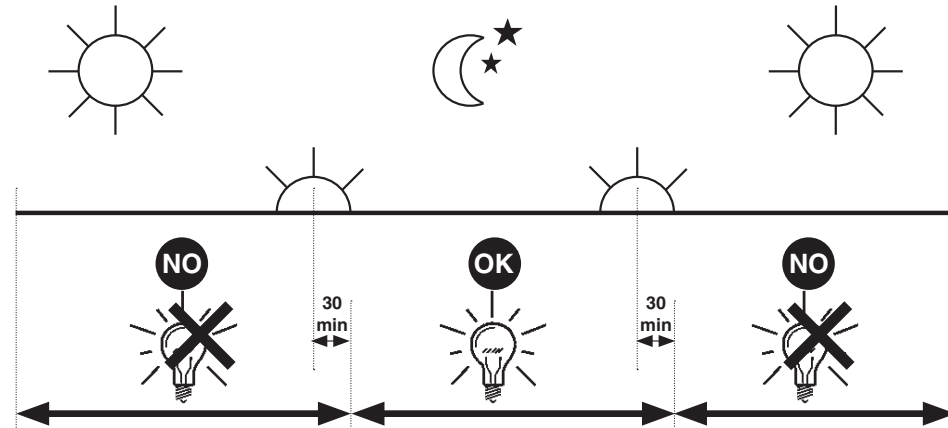

iGuzzini

2.509.386.00
ISO9176/01

الفترة الزمنية اليومية للتشغيل المسموح بها

- I PERIODO GIORNALIERO DI ACCENSIONE AMMESSO
- GB ALLOWED DAILY OPERATION PERIOD
- E PERIODO DIARIO DE ENCENDIDO PERMITIDO

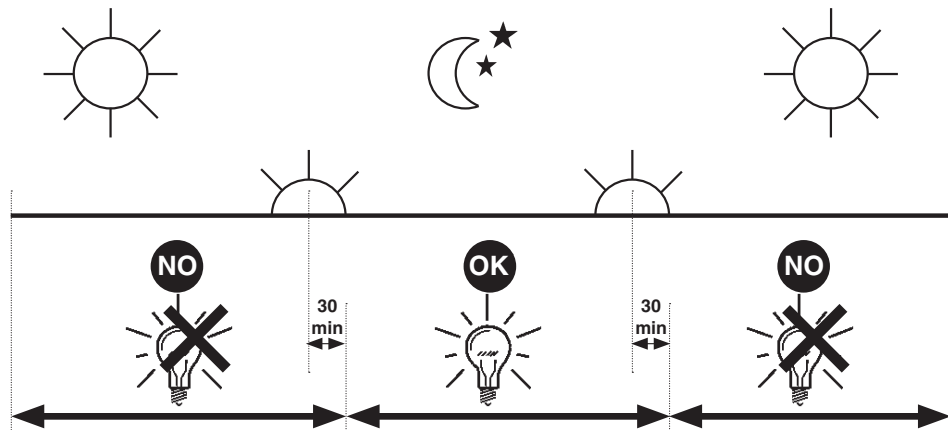

iGuzzini

2.509.386.00
ISO9176/01

الفترة الزمنية اليومية للتشغيل المسموح بها

- I PERIODO GIORNALIERO DI ACCENSIONE AMMESSO
- GB ALLOWED DAILY OPERATION PERIOD
- E PERIODO DIARIO DE ENCENDIDO PERMITIDO

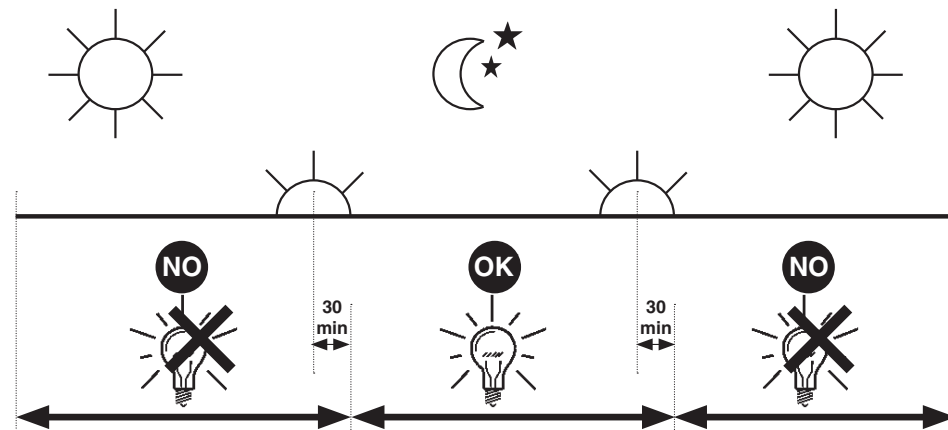



إخراج المُنتج من العبوة، وكذلك إخراج الأجزاء الداخلية من الكرتون؛ مع ترك المُنتج في مكانه الأصلي، كما هو مبين في الشكل.

I Estrarre il prodotto dall'imballo assieme alla parte interna in cartone, lasciandolo nella sua posizione originale come in figura.

GB Remove the product from the package together with the inner cardboard part, leaving it in its original position as shown in the picture.

E Extraer el producto del embalaje junto con la parte interna de cartón, dejándolo en su posición original como en la figura.

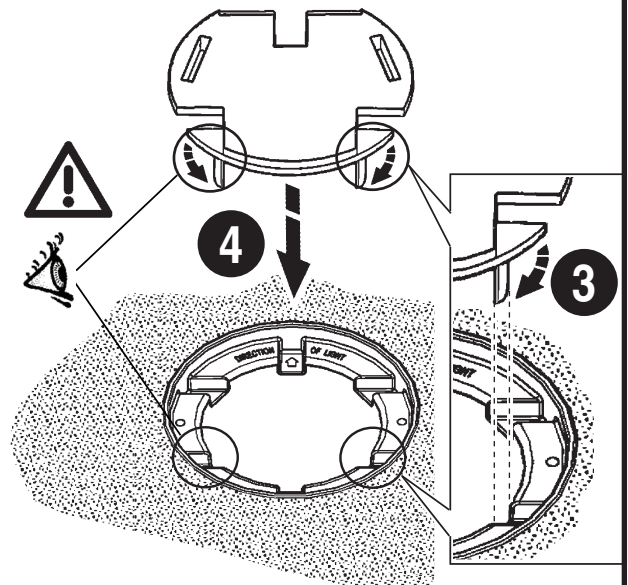
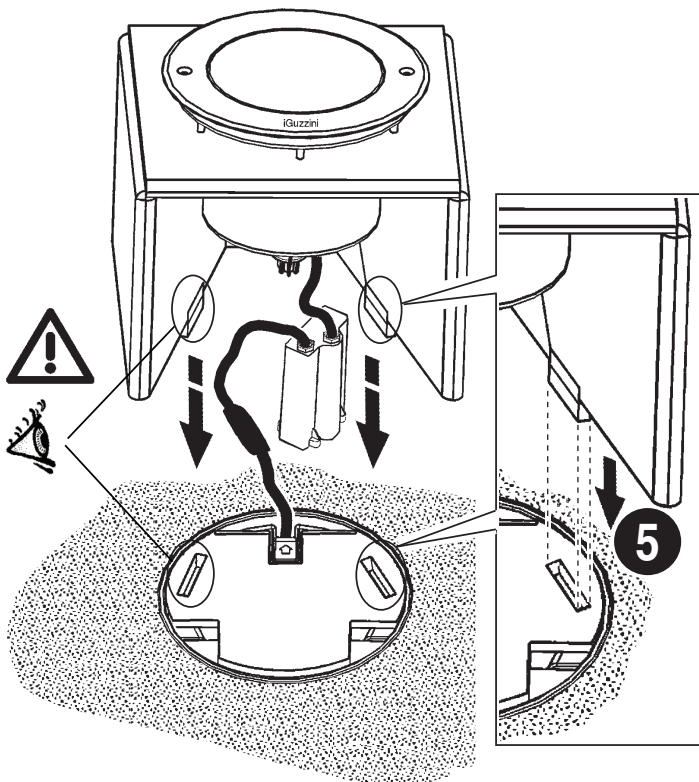
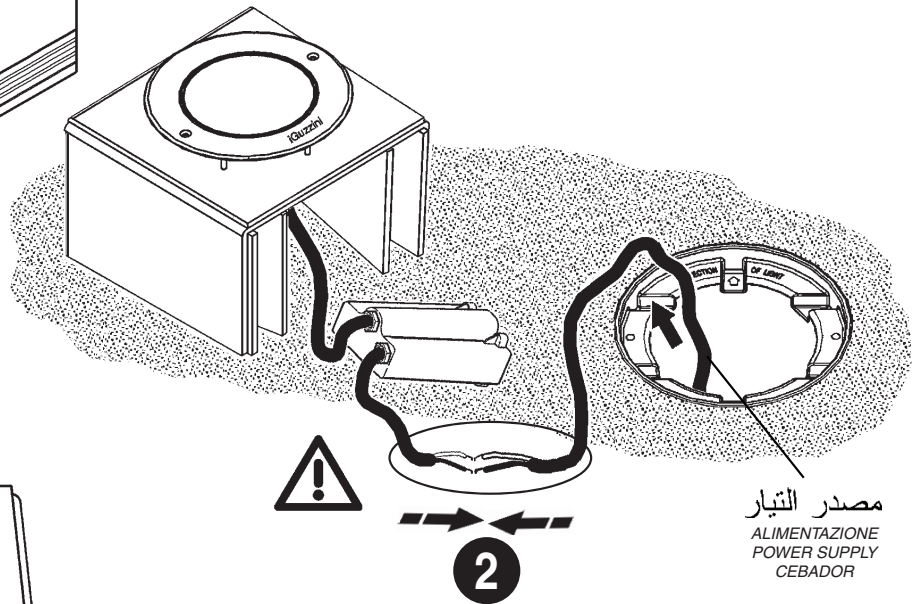
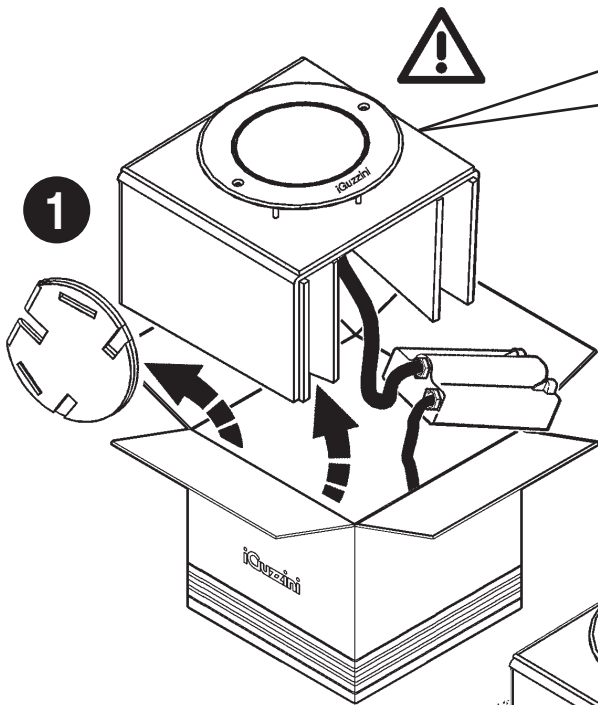

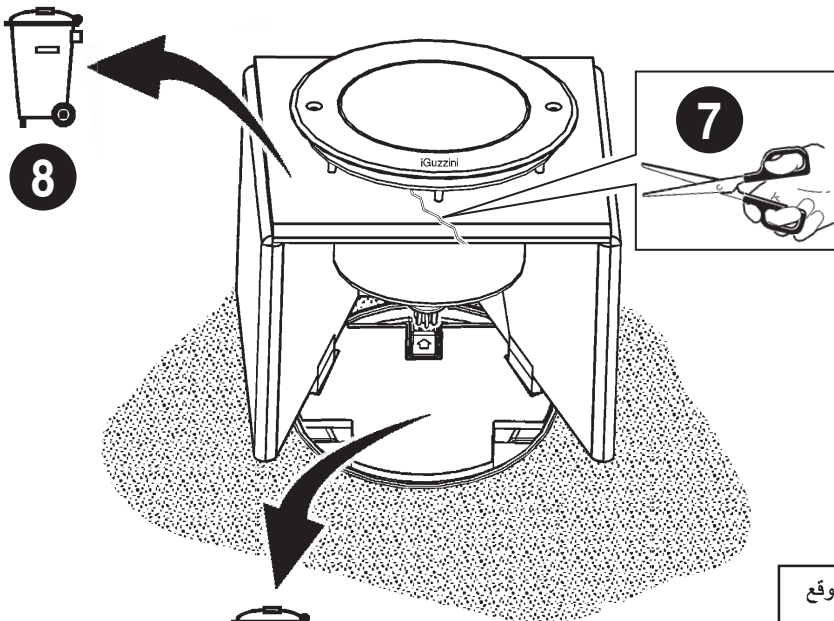
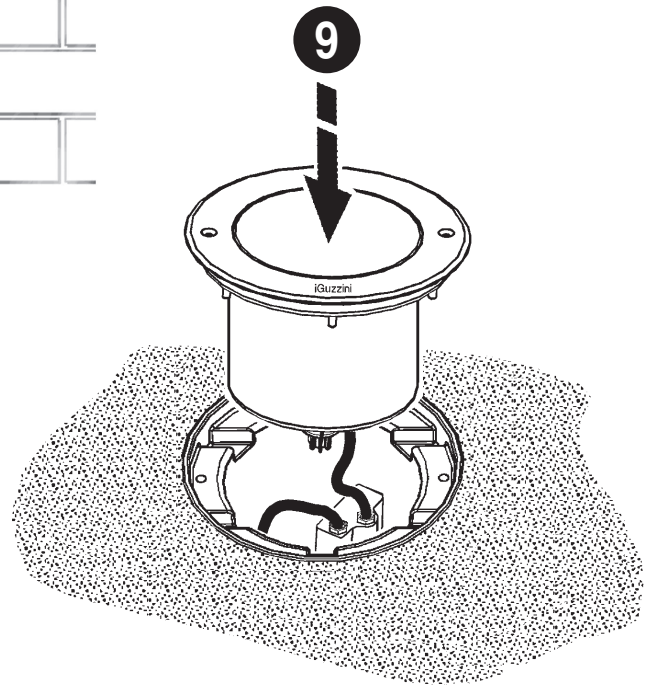
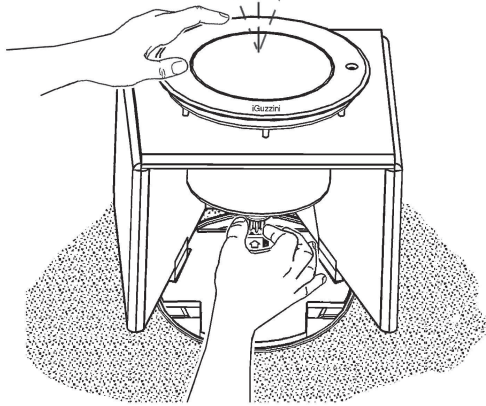
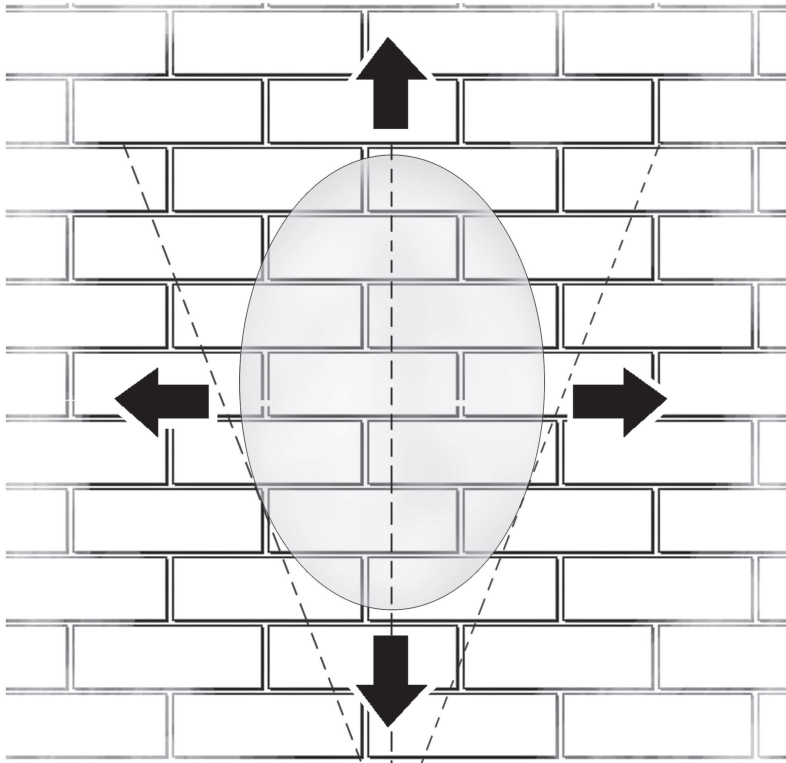

يُرجى مراجعة صفحة التعليمات الخاصة بالمنتج، وكذلك مراجعة موقع "إيجوزيني" (iGuzzini) على شبكة الإنترنت.

I Per tutte le altre informazioni consultare il foglio istruzioni del prodotto e il sito "iGuzzini".

GB For any other information consult the product's instruction sheet and the "iGuzzini" website.

E Para más información consultar la hoja de instrucciones del producto y el sitio "iGuzzini".

- I Istruzioni per le operazioni di servizio per l'apparecchio di illuminazione**
GB Instructions on luminaire service operations
F Instructions pour les opérations de service du luminaire
D Wartungsanleitung für die Leuchte
NL Instructies voor de onderhoudsoperaties op de verlichtingsarmatuur
E Instrucciones para las operaciones de servicio del aparato de alumbrado
DK Anvisninger i serviceindgreb på belysningsarmatur
N Anvisninger for betjening av lysapparatet
S Instruktioner för användning av belysningsanordningen
RUS Инструкция по эксплуатации осветительного прибора
CN 照明装置检修操作说明

Sostituire la lampada parzialmente esausta
 Replace the partly exhausted lamp
 Remplacer la lampe partiellement épuisée
 Die teilweise erschöpfte Lampe austauschen
 Vervang de gedeeltelijk lege lamp
 Sustituir la lámpara parzialmente agotada
 Udskift den delvist udtjente pære
 Skifte ut den delvis utbrente lyspæren
 Byt ut den delvis förbrukade lampan
 Замена частично отработанной лампочки
 更换部分老化的灯泡



Spegnimento
 Switch it off
 Extinction
 Ausschaltung
 Uitschakeling
 Apagado
 Slukning
 Slukking
 Släckning
 Выключение
 关灯

Interrompere l'alimentazione dell'apparecchio
 Cut the power supply to the luminaire
 Couper l'alimentation du luminaire
 Stromversorgung der Leuchte unterbrechen
 Onderbreek de voeding van het apparaat
 Interrumpir la alimentación del aparato
 Afbryd armaturets strømforsyning
 Avbryte strømtilførselen til apparatet
 Koppla från anordningens strömförsörjning
 Отключить электропитание прибора
 中断装置供电



Aprire l'apparecchio
 Open the fixture
 Ouvrir le luminaire
 Das Gerät öffnen
 Open het apparaat
 Abrir el aparato
 Åbn armaturet
 Åpne apparatet
 Öppna anordningen
 Раскрыть прибор
 打开装置

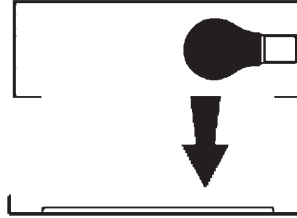

Rimuovere la lampada esausta
 Remove the exhausted lamp
 Retirer la lampe épuisée
 Die alte Lampe entnehmen
 Verwijder de lege lamp
 Quitar la lámpara agotada
 Tag den udtjente pære ud
 Fjerne den utbrente lyspæren
 Ta bort den förbrukade lampan
 Вынуть старую лампочку
 取出老化的灯泡

Portarla in un centro di riciclaggio
 Carry it to a recycling centre
 La porter dans une déchetterie pour son recyclage
 Ordnungsgemäß entsorgen
 Breng de lamp naar een recyclingcentrum
 Llevarla a un centro de reciclaje
 Aflever den på en genbrugsstation
 Lever den til en miljøstasjon
 Lämna in den till en återvinningsanläggning
 Сдать ее в пункт приема утильсырья
 将其送往回收中心

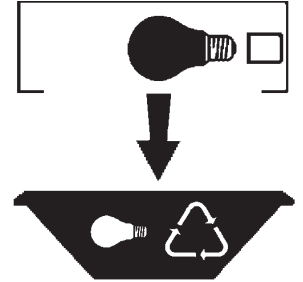

Inserire la nuova lampada
 Introduce the new lamp
 Installer la lampe neuve
 Die neue Lampe einsetzen
 Doe de nieuwe lamp op zijn plek
 Montar la nueva lámpara
 Sæt den nye pære i
 Sette i den nye pæren
 Sätt i den nya lampan
 Вставить новую лампочку
 装入新灯泡

Inserire la nuova lampada nel portalampada
 Fit the new lamp into the socket
 Installer la nouvelle lampe dans le support de lampe
 Die neue Lampe in den Sockel einsetzen
 Doe de nieuwe lamp in de lamphouder
 Montar la nueva lámpara en el portalámpara
 Sæt den nye pære i fatningen
 Sette den nye pæren inn i lampeholderen
 Sätt i den nya lampan i lamphållaren
 Вставить новую лампочку в патрон
 将新灯泡插入灯泡架中



Riposizionare ottica
 Re-place the optic
 Remettre l'optique à sa place
 Die Optik wieder einsetzen
 Doe de optiek weer op zijn plaats
 Volver a montar la óptica
 Sæt den optiske enhed på plads
 Innstille linsen
 Flytta om optiken
 Отрегулировать линзы
 重新定位光头



Effettuare prova di funzionamento
 Perform operative test
 Procéder à un essai de fonctionnement
 Eine Funktionsprüfung durchführen
 Controleer de correcte werking
 Hacer una prueba de funcionamiento
 Afprøv funktionen
 Prøve om den fungerer
 Utför funktionstest
 Выполнить проверку исправности работы
 执行功能测试



I Istruzioni per la pulizia dell'apparecchio di illuminazione
GB Instructions on luminaire cleaning operations
F Instructions pour le nettoyage du luminaire
D Anweisungen zur Reinigung der Leuchte
NL Instructies voor de reiniging van de verlichtingsarmatuur
E Instrucciones para limpiar el aparato de alumbrado
DK Anvisninger i rengøring af belysningsarmaturet
N Anvisninger for rengjøring av lysapparatet
S Instruktioner för rengöring av belysningsanordningen
RUS Инструкции по чистке осветительного прибора
CN 照明装置清洁说明

Pulire l'apparecchio
 Clean the fixture
Nettoyer le luminaire
 Das Gerät reinigen
Reinig het apparaat
 Limpiar el aparato
Rengør armaturet
Rengjøre apparatet
Rengör anordningen
 Чистка прибора
 清洁装置

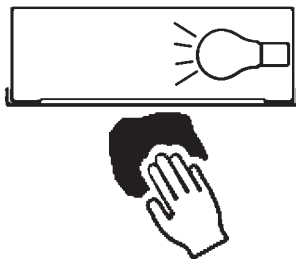

Spegnimento
 Switch it off
Extinction
Ausschaltung
Uitschakeling
Apagado
Slukning
Slukking
Släckning
Выключение
 关灯

Interrompere l'alimentazione dell'apparecchio
 Cut the power supply to the luminaire
 Couper l'alimentation du luminaire
 Stromversorgung der Leuchte unterbrechen
 Onderbreek de voeding van het apparaat
 Interrumpir la alimentación del aparato
 Afbryd armaturets strømforstyrning
 Avbryt strømtilførselen til apparatet
 Koppla från anordningens strömförsörjning
 Отключить электропитание прибора
 中断装置供电



Spolverare l'ottica esterna
 Remove dust from the external optic
Dépoussiérer l'optique extérieure
Die externe Optik abstauben
Stof de externe optiek af
Quitar el polvo de la óptica exterior
Tør støvet af den udvendige optiske enhed
Fjerne støv fra den eksterne lysenheten
Damma av den yttre optiken
Вытереть пыль с внешней стороны линз
 为外侧光头掸尘

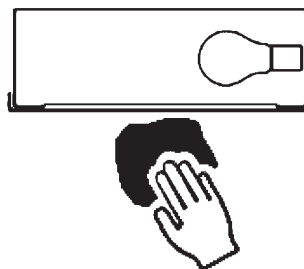

Lavare l'ottica esterna
 Wash the external optic
Laver l'optique extérieure
Die externe Optik waschen
Was de externe optiek
Lavar la óptica exterior
Vask den udvendige optiske enhed
Vaske den eksterne lysenheten
Rengör den yttre optiken
Вымыть линзы с внешней стороны
 清洁外光头



Rimuovere l'ottica
 Remove the optic
Retirer l'optique
Die Optik abnehmen
Verwijder de optiek
Quitar la óptica
Tag den optiske enhed af
Fjerne lysenheten
Ta bort optiken
Снять линзы
 取下光头



Pulire la parte interna dell'apparecchio di illuminazione
 Clean the inside of the fixture
Nettoyer l'intérieur du luminaire
Die Innenseite der Leuchte reinigen
Reinig de binnenzijde van de verlichtingsarmatuur
Limpiar el interior del aparato de alumbrado
Rengør belysningsarmaturets indvendige dele
Rengjøre lysapparatet innvendig
Rengör belysningsanordningen invändigt
Протереть осветительный прибор изнутри
 清洁照明装置内部



Riposizionare ottica
 Re-place the optic
Remettre l'optique à sa place
Die Optik wieder einsetzen
Doe de optiek weer op zijn plaats
Volver a montar la óptica
Sæt den optiske enhed på plads
Innstille linsen
Flytta om optiken
Отрегулировать линзы
 重新定位光头



Effettuare prova di funzionamento
 Perform operative test
Procéder à un essai de fonctionnement
Eine Funktionsprüfung durchführen
Controleer de correcte werking
Hacer una prueba de funcionamiento
Afprøv funktionen
Prøve om den fungerer
Utför funktionstest
Выполнить проверку исправности работы
 执行功能测试

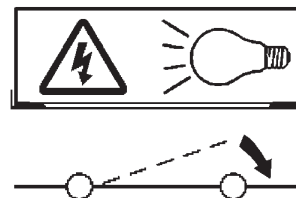

- I Istruzioni per il fine vita e lo smaltimento dei componenti**
GB Instructions on end-of-life and component disposal
F Instructions pour la gestion des composants en fin de vie et leur mise au rebut
D Anweisungen zur Entsorgung der Leuchtenkomponenten
NL Instructies voor het verwijderen van de armatuur en het recyclen van de onderdelen
E Instrucciones para el final de vida y la eliminación los componentes
DK Anvisninger i udtjent armatur og bortskaffelse af komponenter
N Anvisninger for endt levetid og avfallsbehandling av delene
S Instruktionser vid bortskaffning och kassering av komponenter
RUS Инструкции по утилизации прибора и его комплектующих по окончании его срока службы
CN 寿命期结束与零件废弃处置说明

<p>Spegnimento Switch it off Extinction Ausschaltung Uitschakeling Apagado Slukning Slukking Släckning Выключение 关灯</p> <p>Interrompere l'alimentazione dell'apparecchio Cut the power supply to the luminaire Couper l'alimentation du luminaire Stromversorgung der Leuchte unterbrechen Onderbreek de voeding van het apparaat Interrompirla alimentación del aparato Afbryd armaturets strømforsyning Avbryt strømtilførselen til apparatet Koppla från anordningens strömförsörjning Отключить электропитание прибора 中断装置供电</p> 	<p>Rimuovere la/e lampada/e per la dismissione Remove the lamp(s) for decommissioning Retirer la(les) lampe(s) pour sa(leur) mise au rebut Die Lampe/n ordnungsgemäß entsorgen Verwijder de lamp(en) voor het recyclen Quitar la(s) lámpara(s) para el desecho Tag pæren/pærerne ud til bortskaffelse Fjerne lampen/-e som skal kastes Ta bort lampan/-orna för bortskaffningen Вынуть лампочку/и для утилизации прибора 取出需要丢弃的灯泡</p> 	<p>Rimuovere la batteria per la dismissione Remove the battery for decommissioning Retirer la batterie pour sa mise au rebut Die Batterie ordnungsgemäß entsorgen Verwijder de batterij voor het recyclen Quitar la batería para el desecho Tag batteriet ud til bortskaffelse Fjerne batteriet som skal kastes Ta bort batteriet för bortskaffningen Вынуть батарейку для утилизации прибора 取出需要丢弃的电池</p> 	<p>Rimuovere l'apparecchio per la dismissione Remove the fixture for decommissioning Enlever le luminaire pour sa mise au rebut Das Gerät ordnungsgemäß entsorgen Verwijder het apparaat voor het recyclen Quitar el aparato para el desecho Tag armaturet ud til bortskaffelse Fjerne apparatet som skal kastes Ta bort anordningen för bortskaffningen Снять прибор для утилизации 取出需要丢弃的装置</p> 
--	---	---	---

<p>Inviare i materiali ad un centro di raccolta RAEE Send the materials to a WEEE collection centre Envoyer les matériaux dans une déchetterie DEEE Die Materialien in einem WEEE-Zentrum entsorgen Zend de materialen naar een recyclingscentrum voor de AEEA Enviar los materiales a un centro de recogida RAEE Afløver materialerne på et indsamlingscenter for elektronisk udstyr Sende materialene til en miljøstasjon for resirkulering av EE-avfall Skicka materialet till en RAEE uppsamlingscentral Сдать материалы в пункт приема утильсырья 将材料送往电气和电子垃圾回收中心</p> 			
---	--	--	--