

255612

Product Sheet

ares

THE OUTDOOR BY FLOS

ARES s.r.l - Socio Unico
v.le dell'Artigianato n.24 - 20881 Bernareggio - MB (Italy)
www.aresill.net - flos.outdoor@flos.com

Idra

Recessed luminaire for outdoor installation in the ground. Configuration: AISI 316 deep-drawn stainless steel structure with milled AISI 316L stainless steel finish frame. Tempered transparent or sandblasted glass, moulded silicone gasket. The stainless steel structure allows installation on extreme conditions (sea or road salt). Protection Rating: IP67. In compliance with EN 60598-1 standards. Class of insulation: mains-I; low voltage: III. Installation: Ø220mm version: the luminaire is equipped with M20x1,5 metal cable gland and a piece of cable for an easy-to-make connection. Ø130mm version: the luminaire is equipped with M16x1,5 metal cable gland ($4,5\phi$<math><10\text{mm}</math>) and a piece of cable for an easy-to-make connection. LED version 24V is equipped with a dc/dc highly efficient resin-coated converter that removes electromagnetic interference and allows parallel wiring. Idra LED is protected against polarity reversal and sudden voltage peak. LED Ø130 is protected against polarity reversal and it is equipped with a piece of cable for an easy-to-made connection (please provide effective insulation on the connection). Outdoor use requires suitable flexible cables assuring the watertightness of the cable gland. Installation requires a dedicated box for installation (to be ordered separately). It is important to provide a >400mm gravel layer or a drain system (for concrete surface) to ensure good drainage and to avoid water stagnation. We recommend the use of a connection system with a protection degree greater than or equal to the protection degree of the luminaire. The luminaire is supplied with a 2-way terminal block for 3-conductor cables - IP68 H2O STOP

Idra Power LED / Ø 130mm - Transparent Glass - Symmetric Optic - Narrow Beam 10°

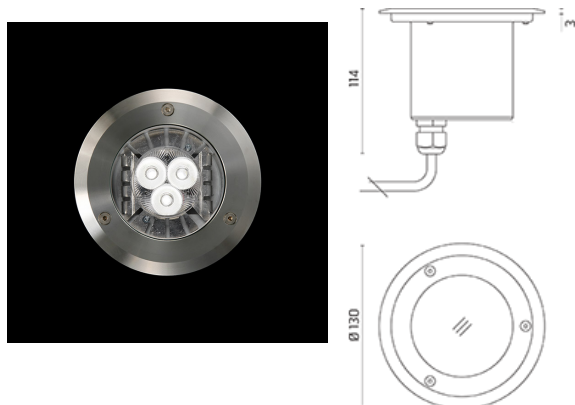

Product Code Details

255612

Light Source



WARM WHITE 3000K POWER LEDs 3,3W/24Vdc
Total power 4,5W
LED lm 330 ÷ OUTPUT lm 252
CRI>80
Remote electronic power supply to be ordered



IP67

Available Colors for this Version

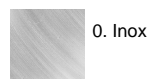

Warnings

Ground Recessed

- Recessed ground fitting
- Do not install in hollow areas
- Protection against water ingress from the cable
H2O STOP
- Static load: 2000Kg walk over
- Check that diffuser's temperature 'T max °C'(tested at 25°C) complies with your local regulation. Glass surface temperature
- Installation requires a 40 cm water drainage layer (gravel)
- Pre-wired with approx 250mm of cable.
- Drive over.
50Nm
5kN
- Protection against impact.
IK 09 - 10,00 joule

Light Flux, Placement



Accessories



Code: 85
Box for installation
Ø 118 H 130 mm



Code: 215
3/4 way terminal block 3 poles IP68
(Ø 5,5-12 mm cable)



Code: 150
Supported n. of lamps: 1
Power supply dual function
Vout 24Vdc: 8W/100÷240V
Iout 350mA: 6X1W/100÷240V
IP20 CLASS II SELV EQ.



Code: 106
Supported n. of lamps: 1
Power supply dual function
Vout 24Vdc: 8W/100÷240V
Iout 350mA: 6X1W/100÷240V - IP65 CLASS II
SELV EQ.



Code: 87
Supported n. of lamps: 2
Power supply
10W/110÷240V - 24Vdc
IP20 CLASS II SELV.



Code: 175
Supported n. of lamps: 2
Power supply
10W/110÷240V - 24Vdc
IP67 CLASS II SELV.



Code: 155
Supported n. of lamps: 7
Power supply
50W/120÷240V - 24Vdc
IP67 CLASS II SELV.



Code: 110
Supported n. of lamps: 14
Power supply
70W/220÷240V - 24Vdc
IP67 CLASS II SELV EQ.