

# TUBE

30-Oct.-2017

## 2.0 LED

LED 2x8W | 220-240VAC | 50-60Hz | COB 3-step | incl. PS | phase-cut dim

CE IP65 0,3m 38°

3000K | 90CRI | 480lm

white texture  
dark grey texture  
black texture

711264W4  
711264D4  
711264B4

## 2.0 PAR16

2xPAR16 max. 35W | GU10 | 100-240VAC | 50-60Hz

CE IP65 0,9m

white texture  
dark grey texture  
black texture

711220W0  
711220D0  
711220B0

### OPTIONAL

for PAR16 lamps see our catalogue

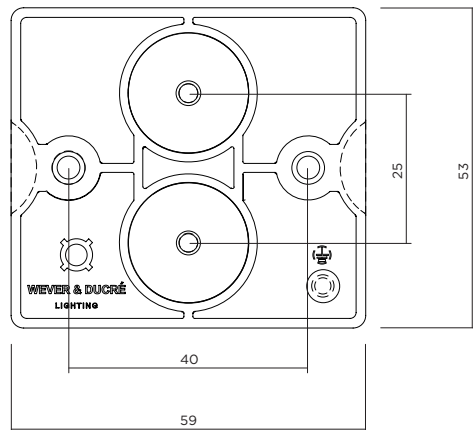

### 2.0 LED

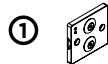

### 2.0 PAR16

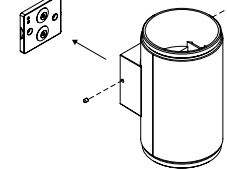
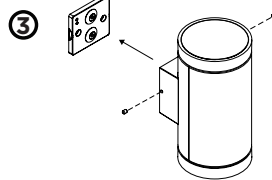

## DIMENSIONS

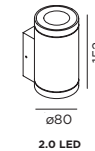

2.0 LED

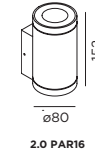

2.0 PAR16

## MOUNTING INSTRUCTION

- 1 Remove the backplate and fixate it to the wall with screws.

## POWER CONNECTION

- 2 Exterior: WATERPROOF Connection

IP-rated connections for wall fixtures: cable isolation for round cables  $\varnothing$  4.5-7.5 mm, should be in the grommet. For cable use  $\varnothing$  7.0-9.5 mm: replace the grommet with the other grommet in the bag.

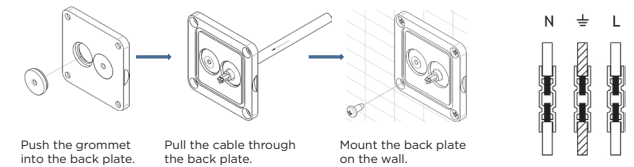

- 3 Fixate the fixture base to the back plate with side screws

- 4 For PAR16:  
Remove the glass cover by turning it.  
Insert the lamp.  
Turn the glass cover back on the fixture.