

NAUTILUS LED 304B

stainless steel brushed, 3x1W warmwhite, IP55

Article number	230802
Catalogue	BIG WHITE 2015, Page 549
Type of lamp	LED lamp
Lamp	Power LED 1W
Number of light sources	3
Lamp included	Yes
Tilt range	270 Degree
Rotation range	360 Degree
Width	10 cm
Height	14.5 cm
Depth	9.5 cm
Diameter	10 cm
Net weight	0.756 kg
Gross weight	0.945 kg
Voltage	230 Volt
Max. wattage	3 Watt
Protection class	I
Beam angle	45 Degree
Material	stainless steel 304
Colour	stainless steel brushed
Way of mounting	surface wall mounting / surface floor mounting / surface ceiling mounting
Remark 1	150 cm connection lead included
Remark 2	LED driver incorporated
Remark 3	Energy labels in your language are available in the Service Area sub point Download
Average lifespan	30000 Hours
Colour temperature	3000 Kelvin
Colour rendering index	>80
Luminous flux	240 lm
Suitable for lamps from EEC	A

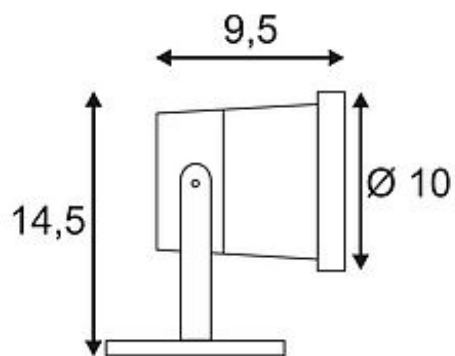

Suitable for lamps up to EEC	A++
Light distribution type 1	direct
Light distribution type 3	rotationally symmetric

Equipped with three high power LED, the surface-mounted luminaire of the NAUTILUS LED 304 series is available in either warm or pure white light colour. By means of the incorporated LED driver, the electrical connection of the stainless steel fitting is made directly to 230V mains supply. Rated IP55 it is suitable for outdoor use. The NAUTILUS LED 304 series further includes a spike version. This luminaire contains built-in LED lamps. EEK: A - A++. The lamps cannot be changed in the luminaire.