

## WETSY LED 300 recessed

square, stainless steel 316, incl. LED module 5W

Article number	230174
Catalogue	BIG WHITE 2015, Page 666
Type of lamp	LED lamp
Lamp	LED Modul 330lm, 5W, 3000K
Number of light sources	1
Lamp included	Yes
Installation diameter	12.6 cm
Installation depth	10 cm
Length	13.2 cm
Width	13.2 cm
Net weight	1.119 kg
Gross weight	3.661 kg
Voltage	230 Volt
Max. wattage	5 Watt
Protection class	I
Material	stainless steel 316
Colour	stainless steel
Way of mounting	recessed ground mounting
Remark 1	LED module 330lm, 5W, 3000K
Remark 2	140 cm connection lead and mounting pot included
Remark 3	Weight capacity 1 ton
Remark 4	Energy labels in your language are available in the Service Area sub point Download
Average lifespan	20000 Hours
Colour temperature	2700 Kelvin
Colour rendering index	80
Luminous flux	300 lm
Suitable for lamps from EEC	A
Suitable for lamps up to EEC	A++
Light distribution type 1	direct

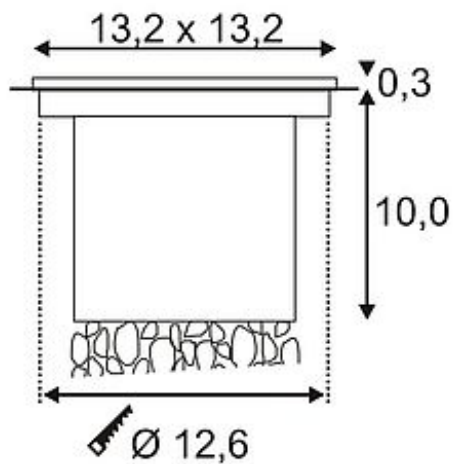

Light distribution  
type 3

asymmetric

The walkable recessed ground luminaire with a round stainless steel bezel and clear glass cover is equipped with the Philips Fortimo LED Disk module providing 300 lumens. Rated IP67, it is suitable for outdoor use. Available in different colour versions, the electrical connection is made directly to 230V mains supply. For simplified mounting, a suitable installation housing is included. This luminaire contains built-in LED lamps. EEK: A - A++. The lamps cannot be changed in the luminaire.