

LED DOWNLIGHT PRO S

square, white, 12W, incl. LED Disk module 800lm, 2700K

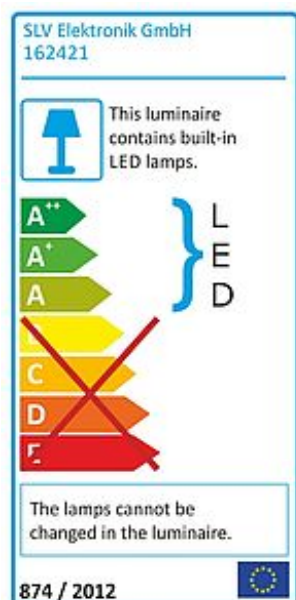

Article number	162421
Catalogue	BIG WHITE 2015, Page 459
Type of lamp	LED lamp
Lamp	Philips Fortimo LED Disk Module
Number of light sources	1
Lamp included	Yes
Installation length	12.5 cm
Installation width	12.5 cm
Installation depth	13.1 cm
Length	14 cm
Width	14 cm
Height	13.8 cm
Net weight	0.685 kg
Gross weight	0.914 kg
Voltage	230 Volt
Max. wattage	12 Watt
Protection class	I
Beam angle	60 Degree
Material	aluminium / glass
Colour	white
Way of mounting	recessed ceiling mounting
Remark 1	For recessed installation in ceilings with a maximum thickness of 35 mm
Remark 2	Equipped with the LED Disk module of Philips
Remark 3	Energy labels in your language are available in the Service Area sub point Download
Average lifespan	50000 Hours
Colour temperature	2700 Kelvin
Colour rendering index	>80
Luminous flux	800 lm
Suitable for lamps from EEC	A

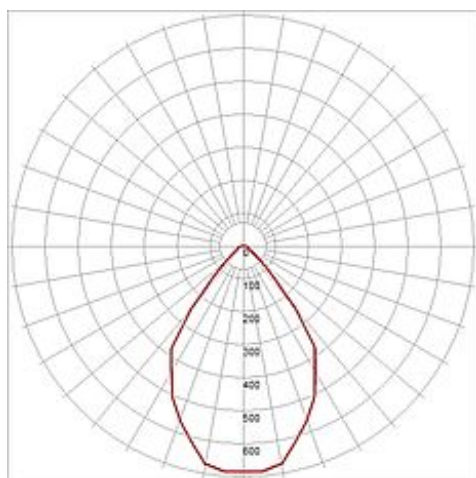
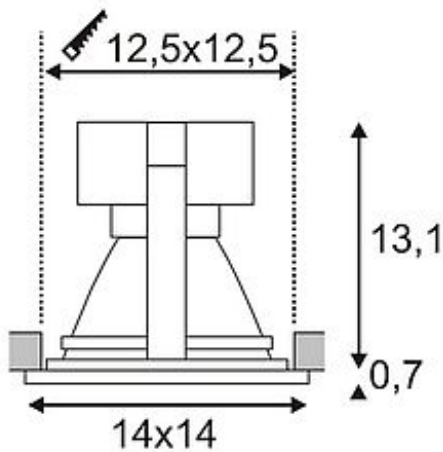

Suitable for lamps up to EEC	A++
Light distribution type 1	direct
Light distribution type 3	axisymmetric

The LED DOWNLIGHT PRO S is a combination of high-quality housing and most efficient LED technology from Philips. With a minimal power consumption despite its high luminous flux and its pure or warmwhite light colour, LED DOWNLIGHT PRO S is ideal to exchange high-intense halogen or incandescent lamps. The LED module is interchangeable. Thanks to the incorporated driver, the downlight is suitable for direct connection to 230V mains supply. This luminaire contains built-in LED lamps. EEK: A - A++. The lamps cannot be changed in the luminaire.