

## ESSENS HQI 70W downlight

white, Rx7s

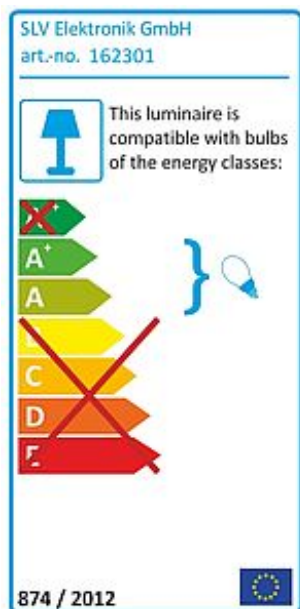

Article number	162301
Type of lamp	Conventional lamp
Lamp	HQI-TS / CDM-TD 70W
Lampholder / Socket	Rx7s
Number of light sources	1
Lamp included	No
Installation diameter	18.5 cm
Installation depth	12 cm
Diameter	20 cm
Net weight	0.709 kg
Gross weight	0.076 kg
Max. wattage	70 Watt
Protection class	I
Material	aluminium / glass
Colour	white
Way of mounting	recessed ceiling mounting
Remark 1	Only suitable for ceilings with a maximum thickness of 40 mm
Remark 2	Operate with suitable ballast only
Remark 3	Energy labels in your language are available in the Service Area sub point Download
Suitable for lamps from EEC	A
Suitable for lamps up to EEC	A+
Light distribution type 1	direct
Light distribution type 3	rotationally symmetric

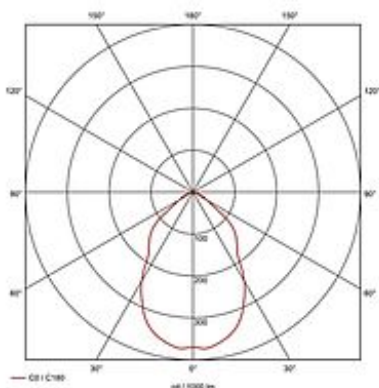
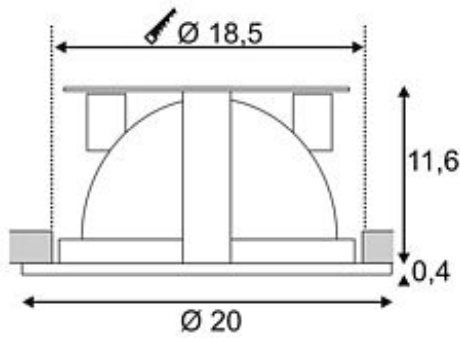

The ESSENS HQI recessed ceiling downlight for commercial applications and those with high demands on clear light characteristics. Available in white and silvergrey colour version, it is ready for 70W metal halide lamps with Rx7s socket. The partly satined glass guarantees glare-free illumination properties. A suitable electronic ballast and a high-voltage connection lead are required for operation. This luminaire is compatible with bulbs of the energy classes: A - A+