

BERET G12 downlight

white, max. 150W

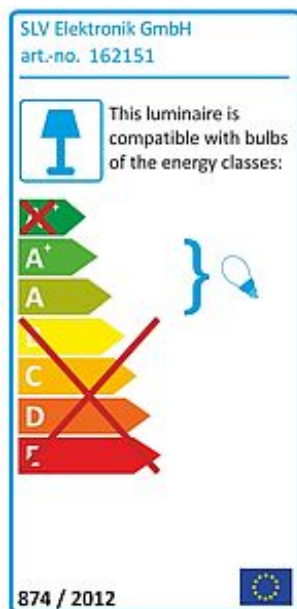

Article number	162151
Catalogue	BIG WHITE 2015, Page 415
Type of lamp	Conventional lamp
Lamp	HQI-T / CDM-T 35W - 150W
Lampholder / Socket	G12
Number of light sources	1
Lamp included	No
Installation diameter	15.2 cm
Installation depth	15.5 cm
Tilt range	30 Degree
Rotation range	30 Degree
Diameter	16.5 cm
Net weight	0.82 kg
Gross weight	0.772 kg
Max. wattage	150 Watt
Protection class	I
Material	aluminium
Colour	white
Way of mounting	recessed ceiling mounting
Remark 1	Only suitable for ceilings with a maximum thickness of 40 mm
Remark 2	Suitable for mounting on normal flammable surfaces while using bulbs with max. 70W
Remark 3	Reflector excluded. Operate with suitable ballast only
Remark 4	Energy labels in your language are available in the Service Area sub point Download
Suitable for lamps from EEC	A
Suitable for lamps up to EEC	A+
Light distribution type 1	direct

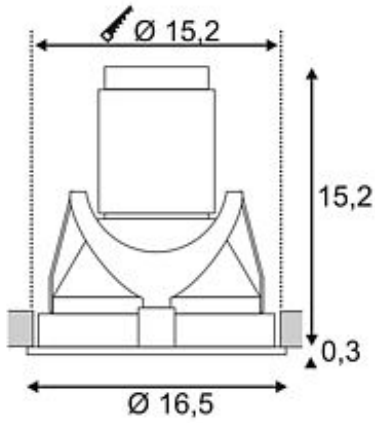

Light distribution type 3 rotationally symmetric

The BERET G12 downlight in round shape with glass cover is equipped with a G12 lampholder for metal halide lamps of the same type. The generously chosen rotation and tilt range of the recessed downlight guarantees the individual orientation of light. Suitable reflectors with different beam angles are available as optional accessory. Available in the colours white and silvergrey, a suitable and lamp related ballast is required for operation of BERET G12. This luminaire is compatible with bulbs of the energy classes: A - A+