

TRIADEM

pendant, triple-headed, A60, white shade, max. 180W

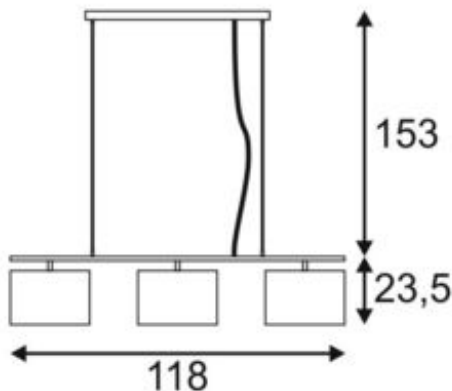
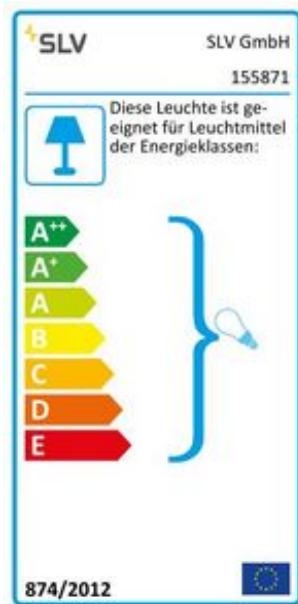

| | |
|---------------------------|------------------------------------|
| Article number | 155871 |
| Light distribution type 1 | direct-indirect |
| Light distribution type 3 | Axis-symmetric |
| Product family | Soprana Oval |
| Feed-in capability | No |
| LBS code | A60 |
| Lamp | A60 |
| Lampholder / Socket | E27 |
| Number of light sources | 3 |
| Lamp included | No |
| Length | 118 cm |
| Width | 15.5 cm |
| Height | 23.5 cm |
| Pendant length | 150 cm |
| Net weight | 3.009 kg |
| Gross weight | 5.367 kg |
| Voltage | 230 ~50 Volts |
| Max. wattage | 60 Watt |
| Protection class | I |
| Material | Textile/polystyrene/steel |
| Colour | white |
| Way of mounting | Surface ceiling mounting (pendant) |
| Energy efficiency class | A++ |
| fastCalcEnabled | No |
| ranking | 300 |
| Catalogue page | BIG WHITE 2017: 113 |

The TRIADEM pendant is an extension of the SOPRANA OVAL family. Thus, the TRIADEM also has beautifully formed and modern textile shades. The entire series is equipped with E27 holders which allow for the use of all variations of standard and energy saving lamps, as well as LEDs. It is connected directly to the 230V mains supply. Irrespective of the individual shade colour, all metal parts have an attractive chrome finish.

