

## SOPRANA TRIPOD floor lamp

white shade , E27, max. 60W

Article number	155733
Catalogue	BIG WHITE 2015, Page 39
Type of lamp	Conventional lamp
Lamp	E27 230V max. 60W
Lampholder / Socket	E27
Number of light sources	1
Lamp included	No
Width	65 cm
Height	155.5 cm
Net weight	2.162 kg
Gross weight	18.684 kg
Voltage	230 Volt
Max. wattage	60 Watt
Protection class	II
Material	steel / textile
Colour	white / chrome
Way of mounting	mobile
Remark 1	Shade (Ø / H): 45,5 / 28,5 cm
Remark 2	330 cm connection lead with switch and plug included
Remark 3	Energy labels in your language are available in the Service Area sub point Download
Suitable for lamps from EEC	E
Suitable for lamps up to EEC	A+
Type of plug	2 pin flat euro plug
Light distribution type 1	direct-indirect
Light distribution type 3	rotationally symmetric

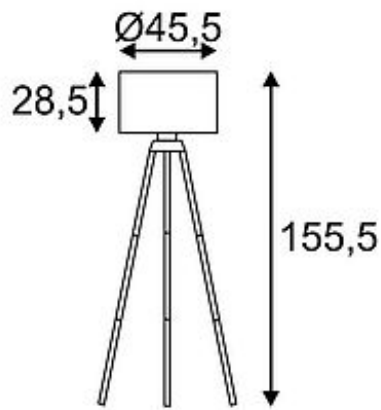

The design floor lamp SOPRANA TRIPOD appears with reference to classic tripods. By three chrome legs and the modern fabric lampshade, the luminaire succeeds in combining both classic and modern design. Equipped with an E27 lampholder and an incorporated switch, the SOPRANA TRIPOD is suitable for LED and energy-saving light sources. The electrical connection is made directly to 230V mains supply via 2-pin plug. This luminaire is compatible with bulbs of the energy classes: E - A+