

BISHADE pendant luminaire

PD-1, 3x E27, max. 3x 23W

Article number	155650
Catalogue	BIG WHITE 2015, Page 67
Type of lamp	Conventional lamp
Lamp	Energy-saving bulb E27 max. 23W
Lampholder / Socket	E27
Number of light sources	3
Lamp included	No
Height	38.5 cm
Diameter	60 cm
Pendant length	150 cm
Net weight	2.878 kg
Gross weight	6.083 kg
Voltage	230 Volt
Max. wattage	69 Watt
Protection class	I
Material	textile / steel
Colour	black / white / chrome
Way of mounting	ceiling mounting pendulum
Remark 1	Maximum length energy saver 14 cm
Remark 2	Two semi-transparent shades. Outside black, inside white
Remark 3	Energy labels in your language are available in the Service Area sub point Download
Suitable for lamps from EEC	A
Suitable for lamps up to EEC	A+
Light distribution type 1	direct-indirect
Light distribution type 3	rotationally symmetric

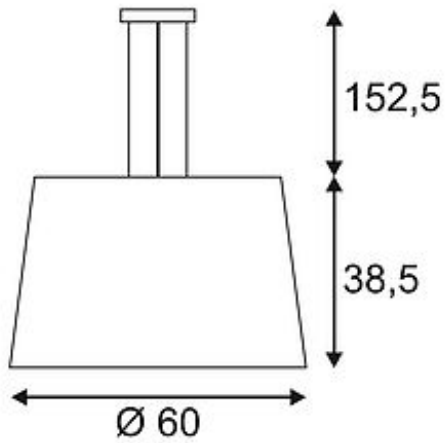

The BISHADE pendant luminaire consists of two optical lamp shades that set a strong design aspect in their combination. Provided for E27 incandescent or energy-saving lamps, BISHADE pendant is ready for direct connection to 230V mains supply. This luminaire is compatible with bulbs of the energy classes: A - A+