

SOPRANA pendant luminaire

PD-4, oval, beige textile, 3x E27, max. 3x 40W

Article number	155283
Catalogue	BIG WHITE 2015, Page 65
Type of lamp	Conventional lamp
Lamp	E27 230V max. 40W
Lampholder / Socket	E27
Number of light sources	3
Lamp included	No
Length	80 cm
Width	30 cm
Height	20 cm
Pendant length	150 cm
Net weight	3.762 kg
Gross weight	2.272 kg
Voltage	230 Volt
Max. wattage	120 Watt
Protection class	I
Material	steel / textile / glass
Colour	beige
Way of mounting	ceiling mounting pendulum
Remark 1	Maximum length energy saver 16 cm
Remark 2	Canopy (L / B / H): 30 / 8,5 / 3,5 cm
Remark 3	The changing look of the shade is a result of stretched beige filaments
Remark 4	Energy labels in your language are available in the Service Area sub point Download
Suitable for lamps from EEC	E
Suitable for lamps up to EEC	A+
Light distribution type 1	direct-indirect
Light distribution type 3	axisymmetric

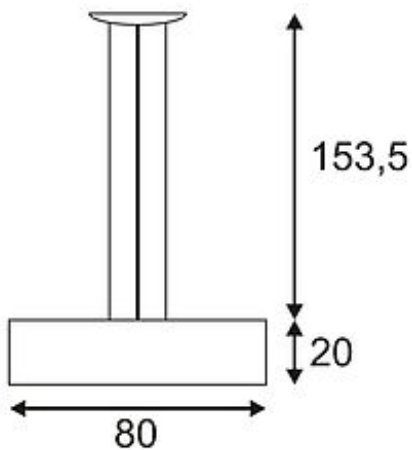

Our high-voltage oval pendant luminaire SOPRANA PD-4, available in either black or beige fabric, is designed for indoor use and three standard E27 bulbs as well as ecen-socketed energy-saving lamps. The clear structure of the lampshade with decorating, reinforcing elements creates a harmonic overall picture by homogeneous and glare-free illumination of the lamp shade. SOPRANA PD-4 is supplied ready direct connection to 230V mains supply and equipped with a 150 cm long suspension. This luminaire is compatible with bulbs of the energy classes: E - A+