

CHROMBO TC-S wall lamp

square , chrome, 11W, up-down

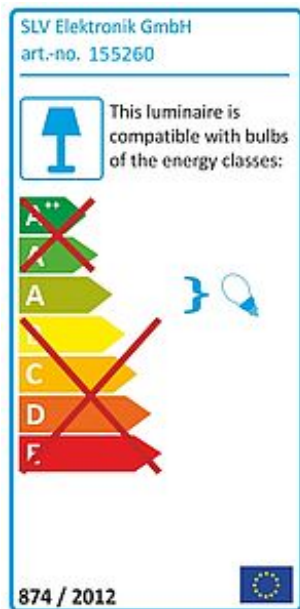

Article number	155260
Catalogue	BIG WHITE 2015, Page 185
Type of lamp	Conventional lamp
Lamp	TC-S compact fluorescent bulb 11W
Lampholder / Socket	G23
Number of light sources	1
Lamp included	No
Width	30 cm
Height	10 cm
Depth	9 cm
Net weight	1.833 kg
Gross weight	0.904 kg
Voltage	230 Volt
Max. wattage	11 Watt
Protection class	I
Material	steel / glass
Colour	chrome
Way of mounting	surface wall mounting
Remark 1	Conventional ballast incorporated
Remark 2	Energy labels in your language are available in the Service Area sub point Download
Energy class ballast	B2
Suitable for lamps from EEC	A
Suitable for lamps up to EEC	A
Light distribution type 1	direct-indirect
Light distribution type 3	axisymmetric

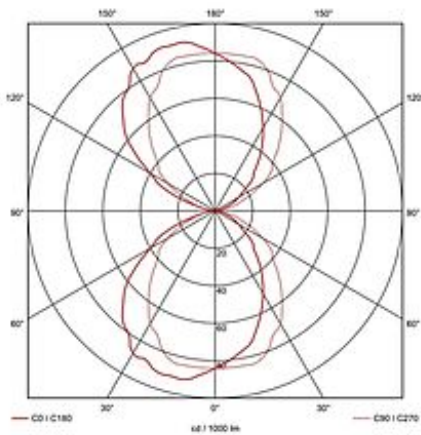
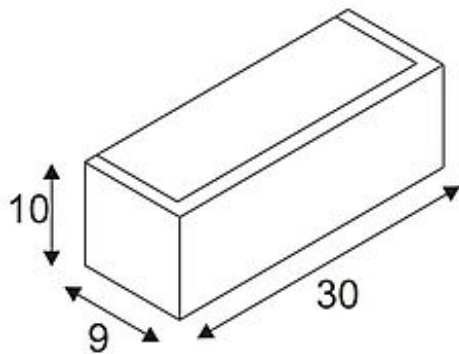

The high-voltage wall luminaire CHROMBO TC-S is a combination of chrome-plated steel and frosted glass and is available in either white or chrome colour version. Prepared for TC-S energy-saving lamps with G23 socket, CHROMBO TC-S is ready for direct connection to 230V mains supply via the incorporated, low-loss ballast. This luminaire is compatible with bulbs of the energy classes: A - A