

KALU TRACK QRB111

black, max. 50W, incl. 3-circuit adaptor

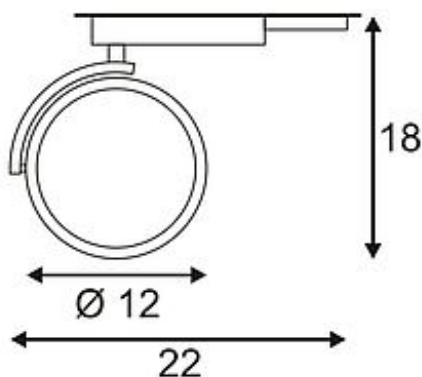
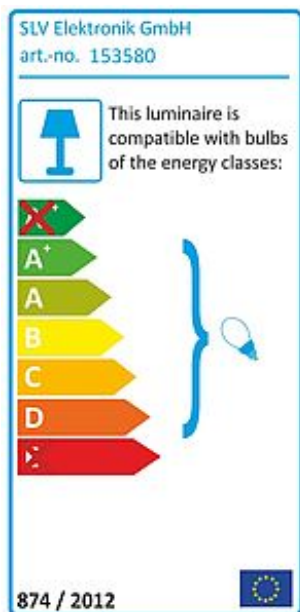

Article number	153580
Catalogue	BIG WHITE 2015, Page 315
Type of lamp	Conventional lamp
Lamp	QRB 111 12V max. 50W
Lampholder / Socket	G53
Number of light sources	1
Lamp included	No
Tilt range	90 Degree
Rotation range	350 Degree
Height	18 cm
Diameter	12 cm
Net weight	0.318 kg
Gross weight	0.292 kg
Voltage	230 Volt
Max. wattage	50 Watt
Protection class	II
Material	aluminium / plastic
Colour	black
Way of mounting	track system mounting
Remark 1	Electronic transformer incorporated
Remark 2	Energy labels in your language are available in the Service Area sub point Download
Suitable for lamps from EEC	D
Suitable for lamps up to EEC	A+
Light distribution type 1	direct
Light distribution type 3	rotationally symmetric

Adjustable spotlight KALU TRACK QRB111 with suitable adapter for the 3 circuit high-voltage track system. Conceived as an extension to the popular KALU series this track spotlight takes on the shape of the product family. By means of the combination of track adapter and transformer, the operation of low-voltage light sources on a high-voltage track is ensured. To meet all lighting requirements, we alternatively offer versions with GX53 socket and such with incorporated Philips LED modules for the 1- and 3-circuit systems. This luminaire is compatible with bulbs of the energy classes: D - A+