

EURO SPOT LED DLMI 1100lm

white, 15W, 3000K, 60°, incl. incl. 3-circuit adaptor

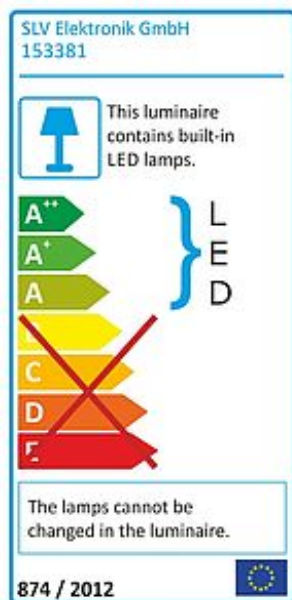
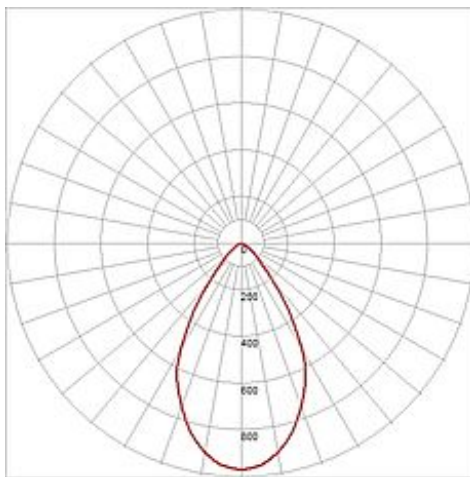

Article number	153381
Catalogue	BIG WHITE 2015, Page 317
Type of lamp	LED lamp
Lamp	Philips Fortimo DLMi Module
Number of light sources	1
Lamp included	Yes
Tilt range	100 Degree
Rotation range	350 Degree
Length	27.5 cm
Width	16.5 cm
Diameter	12.5 cm
Net weight	1.552 kg
Gross weight	4.741 kg
Voltage	230 Volt
Max. wattage	15 Watt
Protection class	I
Beam angle	60 Degree
Material	aluminium
Colour	white
Way of mounting	track system mounting
Remark 1	Equipped with the Fortimo LED DLMI module of Philips
Remark 2	Energy labels in your language are available in the Service Area sub point Download
Average lifespan	25000 Hours
Colour temperature	3000 Kelvin
Colour rendering index	>80
Luminous flux	1100 lm
Suitable for lamps from EEC	A
Suitable for lamps up to EEC	A++
Light distribution type 1	direct

Light distribution
type 3

rotationally symmetric

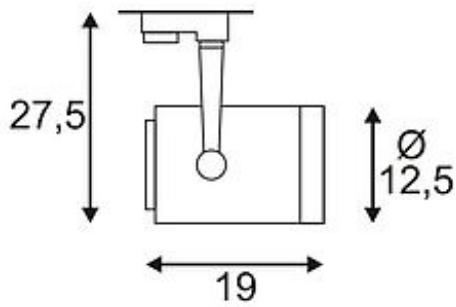

Adjustable high-voltage LED spotlight EURO SPOT LED DLMi with suitable adaptor for 3-circuit high-voltage track system. Within the cylindrical lamp head the powerful Philips DLMi 1100lm LED module is already installed. Available in several colour versions EURO SPOT DLMi is available in either warm or pure white light colour. This luminaire contains built-in LED lamps. EEK: A - A++. The lamps cannot be changed in the luminaire.