

FORCHINI M pendant lamp

40cm, round, white/gold, E27, with white 3-circuit adaptor

Article number	153131
Catalogue	BIG WHITE 2015, Page 341
Type of lamp	Conventional lamp
Lamp	E27 230V max. 40W
Lampholder / Socket	E27
Number of light sources	1
Lamp included	No
Height	40 cm
Diameter	20 cm
Pendant length	150 cm
Net weight	2.29 kg
Gross weight	0.833 kg
Voltage	230 Volt
Max. wattage	40 Watt
Protection class	II
Material	steel
Colour	white / gold
Way of mounting	track system mounting
Remark 1	Maximum measures energy saver (Ø / L): 6,8 / 15,2 cm
Remark 2	The mounted adaptor is suitable for all conventional 3 circuit tracks
Remark 3	Energy labels in your language are available in the Service Area sub point Download
Suitable for lamps from EEC	E
Suitable for lamps up to EEC	A+
Light distribution type 1	direct
Light distribution type 3	rotationally symmetric

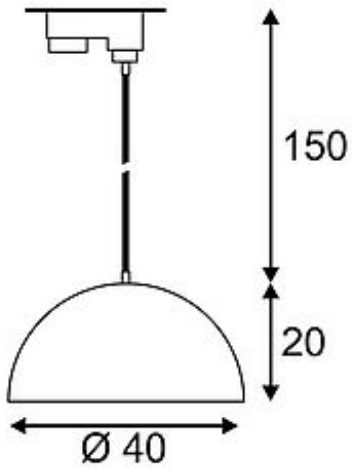

High-voltage pendant luminaire FORCHINI M with suitable adapter for the 3 circuit high-voltage track system. Available in the colours black and white, the inner side gold coloured aluminium lampshade features a standard E27 lamp holder. Thus, the fitting is suitable for energy-saving and LED light sources. The pendulum length is 150 cm. This luminaire is compatible with bulbs of the energy classes: E - A+