

SUPROS TRACK 3000 Spot

white, 3000lm, 3000K SLM LED, 60° reflector, incl. 3-circuit adator

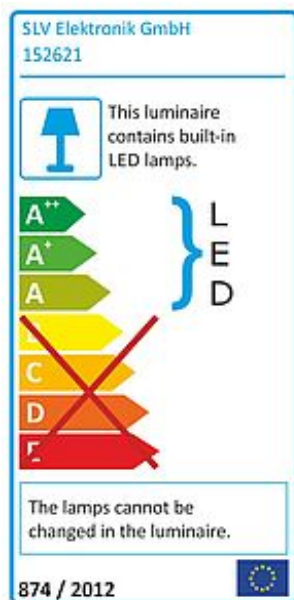

Article number	152621
Catalogue	BIG WHITE 2015, Page 323
Type of lamp	LED lamp
Lamp	Philips Fortimo LED SLM Module
Number of light sources	1
Lamp included	Yes
Tilt range	190 Degree
Rotation range	350 Degree
Length	24.5 cm
Height	21.5 cm
Diameter	12.7 cm
Net weight	1.54 kg
Gross weight	0.428 kg
Voltage	230 Volt
Max. wattage	34.8 Watt
Protection class	I
Beam angle	60 Degree
Material	aluminium
Colour	white
Way of mounting	track system mounting
Remark 1	The mounted adapter is suitable for all conventional 3 circuit tracks
Remark 2	Equipped with the Fortimo LED SLM module of Philips
Remark 3	Energy labels in your language are available in the Service Area sub point Download
Average lifespan	50000 Hours
Colour temperature	3000 Kelvin
Colour rendering index	>80
Luminous flux	3000 lm
Suitable for lamps from EEC	A
Suitable for lamps up to EEC	A++

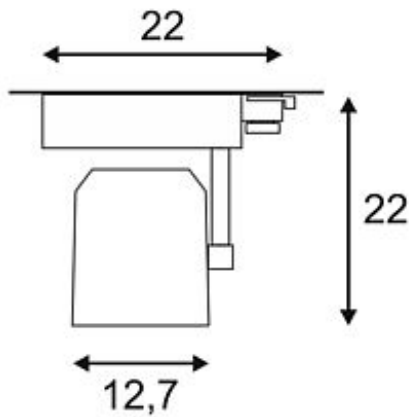

Light distribution type 1	direct
---------------------------	--------

Light distribution type 3	rotationally symmetric
---------------------------	------------------------

Consisting of two downlights, one surface-mounted downlight, a 3-circuit system spot and a pendant lamp our lighting series Supros convinces by versatility, outstanding LED technology and a harmonious design. With its very high luminous flux the product family Supros is ideally suited for the exchange of high-powered, conventional lighting systems. The integrated and wide flooding reflector can be exchanged with separately available reflectors with smaller beam angles without the use of any tools. Thanks to the incorporated LED drivers, all fittings of this series are suitable for direct connection to 230V mains supply. This luminaire contains built-in LED lamps. EEK: A - A++. The lamps cannot be changed in the luminaire.