

## KALU TRACK LEDDISK lamp head

silvergrey, 3000K, incl. 3-circuit adaptor

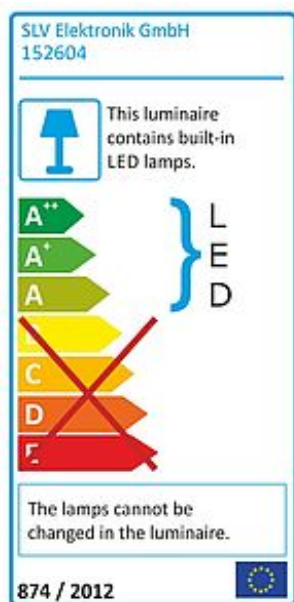

Article number	152604
Catalogue	BIG WHITE 2015, Page 314
Type of lamp	LED lamp
Lamp	Philips Fortimo LED Disk Module
Number of light sources	1
Lamp included	Yes
Tilt range	90 Degree
Rotation range	350 Degree
Length	13.5 cm
Height	17 cm
Net weight	0.498 kg
Gross weight	0.609 kg
Voltage	230 Volt
Max. wattage	12 Watt
Protection class	II
Material	aluminium
Colour	silvergrey
Way of mounting	track system mounting
Remark 1	The mounted adapter is suitable for all conventional 3 circuit tracks
Remark 2	Energy labels in your language are available in the Service Area sub point Download
Average lifespan	25000 Hours
Colour temperature	3000 Kelvin
Colour rendering index	>80
Luminous flux	800 lm
Suitable for lamps from EEC	A
Suitable for lamps up to EEC	A++
Light distribution type 1	direct
Light distribution type 3	rotationally symmetric

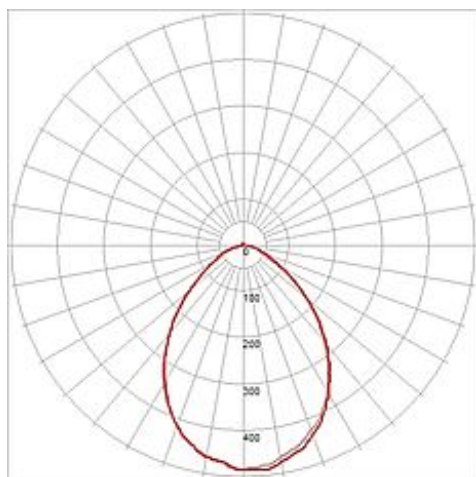
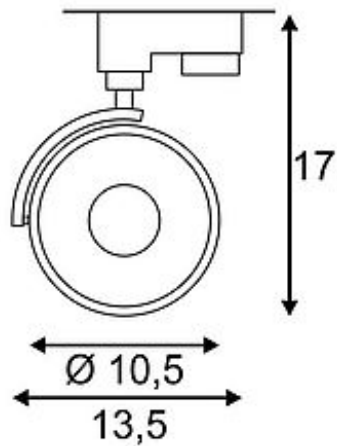

Adjustable spotlight KALU TRACK LEDDISK with suitable adapter for the 3 circuit high-voltage track system. Conceived as an extension to the popular KALU series, this track spotlight takes on the shape of the product family. By the incorporated Philips LED module, a high light output with low electricity consumption is guaranteed. To meet all lighting requirements, we alternatively offer versions with G53 and GX53 sockets, as well as versions for the 1- and 3-circuit systems. This luminaire contains built-in LED lamps. EEK: A - A++. The lamps cannot be changed in the luminaire.