

DOWNUNDER

RCL 101, square, stainless steel brushed, 2W, 10 LED, warmwhite, 3200K

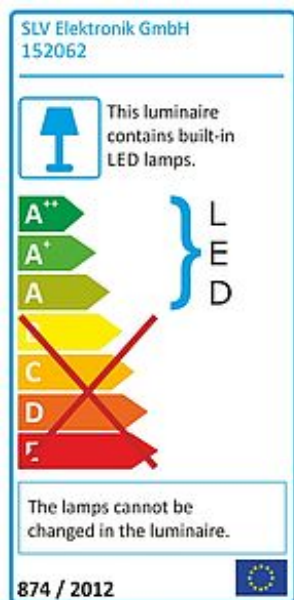

Article number	152062
Catalogue	BIG WHITE 2015, Page 474
Type of lamp	LED lamp
Lamp	SMD LED
Number of light sources	10
Lamp included	Yes
Installation length	11.4 cm
Installation width	5.4 cm
Installation depth	4.5 cm
Width	12.5 cm
Height	6.5 cm
Depth	4.7 cm
Net weight	0.264 kg
Gross weight	0.822 kg
Voltage	24 Volt
Max. wattage	2 Watt
Protection class	III
Material	aluminium / stainless steel 304
Colour	stainless steel brushed
Way of mounting	recessed wall mounting
Remark 1	Power supply excluded
Remark 2	Only suitable for cavity walls with a material thickness of max. 15 mm
Remark 3	Energy labels in your language are available in the Service Area sub point Download
Average lifespan	20000 Hours
Colour temperature	3000 Kelvin
Colour rendering index	>80
Luminous flux	190 lm
Suitable for lamps from EEC	A

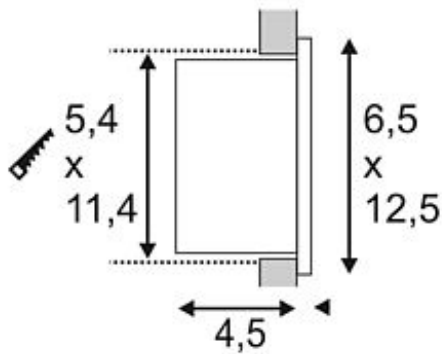

Suitable for
lamps up to EEC A++

Light distribution type 1	direct
------------------------------	--------

Light distribution type 2	indirect
------------------------------	----------

Aluminum recessed wall luminaire of our DOWNUNDER series. The not visibly mounted SMD LED emits the light indirectly onto the surface to be illuminated. This guarantees glare-free illumination of sidewalks and much more. To operate the DOWNUNDER RCL 101 recessed luminaire, a suitable LED power supply is required providing 24V direct current. A mounting frame for installation in masonry can be ordered from the accessory. This luminaire contains built-in LED lamps. EEK: A - A++. The lamps cannot be changed in the luminaire.