

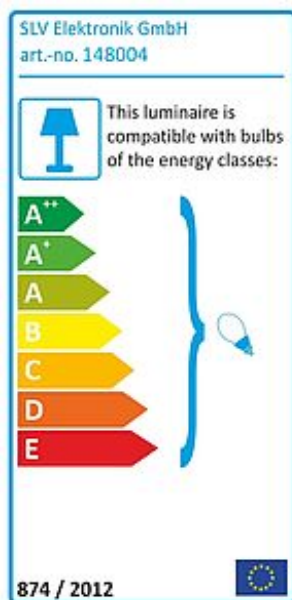

PLASTRA ceiling luminaire

CL-1, square, white plaster, GU10, max. 35W



Article number	148004
Catalogue	BIG WHITE 2015, Page 278
Type of lamp	Conventional lamp
Lamp	GU10 230V max. 35W
Lampholder / Socket	GU10
Number of light sources	1
Lamp included	No
Length	9 cm
Width	9 cm
Height	13.5 cm
Net weight	1.074 kg
Gross weight	2.914 kg
Voltage	230 Volt
Max. wattage	35 Watt
Protection class	I
Material	plaster
Colour	white
Way of mounting	surface ceiling mounting
Remark 1	The fitting is paintable with wall paint
Remark 2	Energy labels in your language are available in the Service Area sub point Download
Suitable for lamps from EEC	E
Suitable for lamps up to EEC	A++
Light distribution type 1	direct
Light distribution type 3	rotationally symmetric

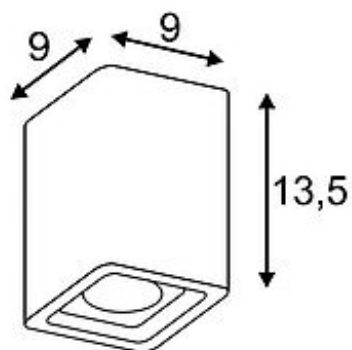

With the plaster lamp PLASTRA CL-1, you own a highly individual ceiling luminaire with puristic and clear design. Prepared for the use of GU10 halogen or LED retrofit lamps, PLASTRA is ready for direct connection to 230V mains supply. Some sandpaper is included in the package and used for surface cleaning. After priming it can easily be painted over with standard wall paint. This luminaire is compatible with bulbs of the energy classes: E - A++