

FORCHINI M pendant luminaire

40cm, round, white/ gold, E27, incl. 1-circuit adaptor

Article number	143931
Catalogue	BIG WHITE 2015, Page 359
Type of lamp	Conventional lamp
Lamp	E27 230V max. 40W
Lampholder / Socket	E27
Number of light sources	1
Lamp included	No
Height	20 cm
Diameter	40 cm
Pendant length	150 cm
Net weight	2.122 kg
Gross weight	0.871 kg
Voltage	230 Volt
Max. wattage	40 Watt
Protection class	II
Material	steel
Colour	white / gold
Way of mounting	track system mounting
Remark 1	Maximum measures energy saver (Ø / L): 6,8 / 15,2 cm
Remark 2	Energy labels in your language are available in the Service Area sub point Download
Suitable for lamps from EEC	E
Suitable for lamps up to EEC	A+
Light distribution type 1	direct
Light distribution type 3	rotationally symmetric

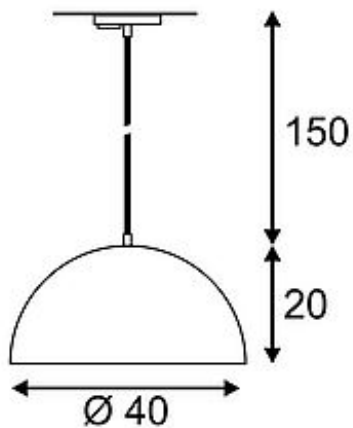

High-voltage pendant luminaire FORCHINI M with suitable adapter for the 1-circuit high-voltage track system. Available in the black and white colour version, the gold-colored inner surface of the shade hosts the standard E27 lampholder. Thus, the luminaire is suitable for energy-saving and LED lamps. The rope measures 150cm in length. This luminaire is compatible with bulbs of the energy classes: E - A+