

EURO SPOT INTEGRATED LED

silvergrey, 13W, 3000K, 24°, incl. 1-circuit adaptor

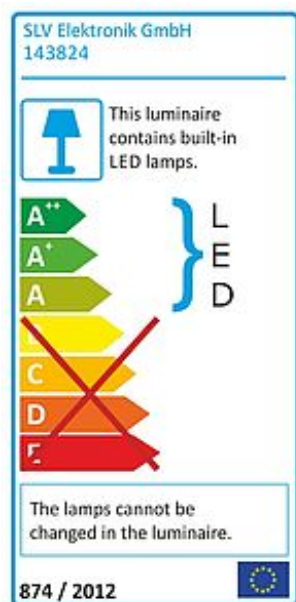

Article number	143824
Catalogue	BIG WHITE 2015, Page 350
Type of lamp	LED lamp
Lamp	Philips Fortimo LED Integrated Spot-Module
Number of light sources	1
Lamp included	Yes
Tilt range	100 Degree
Rotation range	350 Degree
Length	16 cm
Height	17.5 cm
Diameter	8 cm
Net weight	0.809 kg
Gross weight	0.585 kg
Voltage	230 Volt
Max. wattage	12.6 Watt
Protection class	I
Beam angle	24 Degree
Material	aluminium
Colour	silvergrey
Way of mounting	track system mounting
Remark 1	Equipped with the LED integrated spot module of Philips
Remark 2	Energy labels in your language are available in the Service Area sub point Download
Average lifespan	50000 Hours
Colour temperature	3000 Kelvin
Colour rendering index	>80
Luminous flux	640 lm
Suitable for lamps from EEC	A
Suitable for lamps up to EEC	A++
Light distribution type 1	direct

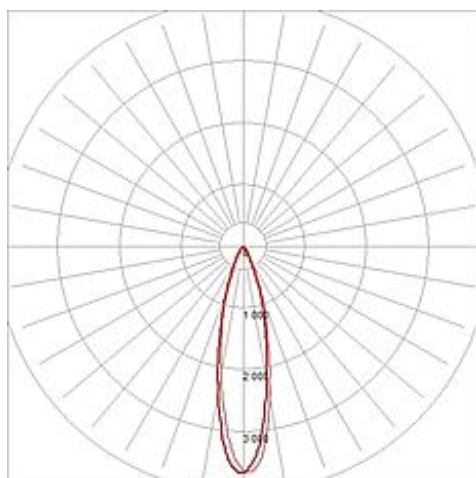
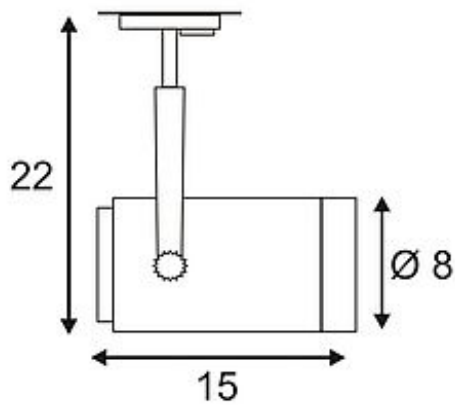

Light distribution
type 3

rotationally symmetric

Adjustable high-voltage spotlight EURO SPOT INTEGRATED LED with adapter for the 1-circuit high-voltage track system. The powerful Philips Fortimo Integrated Spot module in warmwhite light colour is placed within the cylindrical lamp head. This luminaire contains built-in LED lamps. EEK: A - A++. The lamps cannot be changed in the luminaire.