

KALU TRACK GX53 SPOT

white, GX53, max. 9W, incl. 1-circuit adaptor

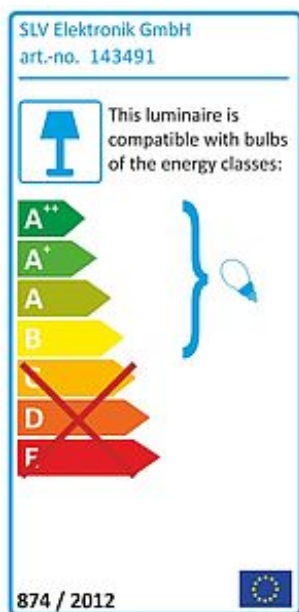

| | |
|------------------------------|---|
| Article number | 143491 |
| Catalogue | BIG WHITE 2015, Page 351 |
| Type of lamp | Conventional lamp |
| Lamp | Microlynx 230V 9W |
| Lampholder / Socket | GX53 |
| Number of light sources | 1 |
| Lamp included | No |
| Tilt range | 90 Degree |
| Rotation range | 350 Degree |
| Length | 12 cm |
| Height | 15 cm |
| Net weight | 0.285 kg |
| Gross weight | 0.433 kg |
| Voltage | 230 Volt |
| Max. wattage | 9 Watt |
| Protection class | I |
| Material | aluminium |
| Colour | white |
| Way of mounting | track system mounting |
| Remark 1 | Head (Ø / L): 10,5 / 4 cm |
| Remark 2 | Energy labels in your language are available in the Service Area sub point Download |
| Suitable for lamps from EEC | B |
| Suitable for lamps up to EEC | A++ |
| Light distribution type 1 | direct |
| Light distribution type 3 | rotationally symmetric |

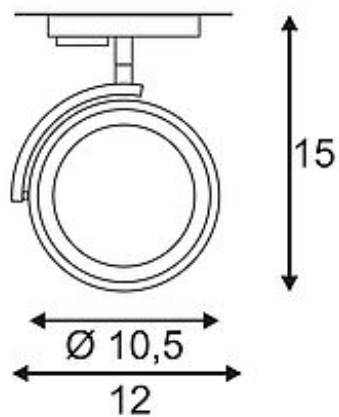

Adjustable spotlight KALU TRACK GX53 with suitable adapter for the 1-circuit high-voltage track system. Conceived as an extension of the popular KALU series, this new spotlight takes on the shape of the product family. The incorporated GX53 socket ensures operation of energy-saving and LED lamps. To meet all lighting requirements, we additionally offer versions with G53 socket and with Philips LED modules for the 1- and 3-circuit systems. This luminaire is compatible with bulbs of the energy classes: B - A++