

NEW TRIA 2 recessed fitting

double-headed, QPAR111, rectangular, matt white, max. 150W, incl. clip springs

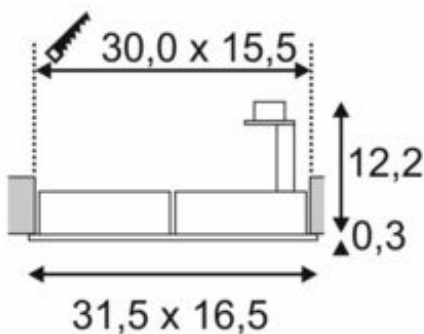
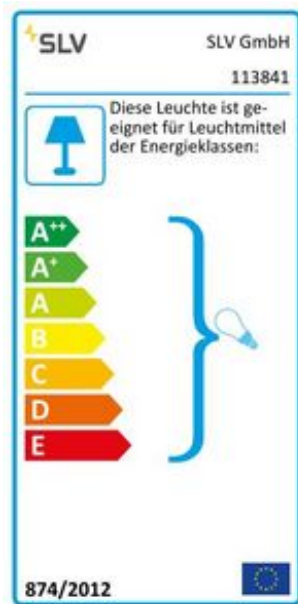

Article number	113841
Light distribution type 1	Direct
Feed-in capability	No
LBS code	QPAR111
Lamp	QPAR111
Lampholder / Socket	GU10
Number of light sources	2
Lamp included	No
Installation length	30 cm
Installation width	15.5 cm
Installation depth	12.5 cm
Tilt range	30 Degree
Rotation range	360 Degree
Length	31.5 cm
Width	16.5 cm
Height	12.5 cm
Net weight	0.821 kg
Gross weight	0.971 kg
Voltage	230 ~50 Volts
Max. wattage	75 Watt
Protection class	I
Material	Aluminium
Colour	matt white
Way of mounting	Recessed ceiling mounting
Energy efficiency class	A++
fastCalcEnabled	No
ranking	200
Catalogue page	BIG WHITE 2017: 433

The square ES111 high-voltage version of our popular NEW TRIA recessed fitting series is available with matt black, matt white or brushed aluminium housings. The generous rotation and pivoting range of this recessed spot guarantees you the ability to individually focus its light beam, regardless of whether you choose to use halogen or LED retrofit lamps. The NEW TRIA 2 recessed fitting is supplied ready for direct connection to the 230V alternating current.