

## NEW TRIA I MR16 downlight

square, matt white, max. 50W

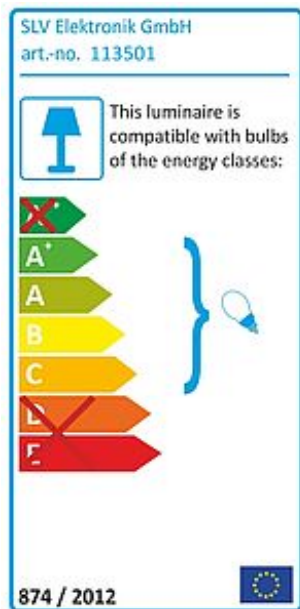
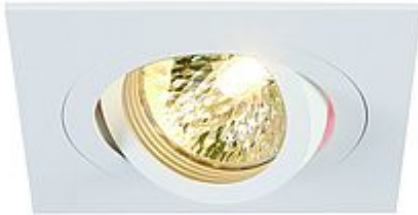

Article number	113501
Catalogue	BIG WHITE 2015, Page 439
Type of lamp	Conventional lamp
Lamp	MR16 12V max. 50W
Lampholder / Socket	GX5,3
Number of light sources	1
Lamp included	No
Installation diameter	7.8 cm
Installation depth	10.5 cm
Tilt range	30 Degree
Rotation range	360 Degree
Length	9 cm
Width	9 cm
Height	11 cm
Net weight	0.159 kg
Gross weight	0.604 kg
Voltage	12 Volt
Max. wattage	50 Watt
Protection class	III
Material	aluminium
Colour	white
Way of mounting	recessed ceiling mounting
Remark 1	Not suitable for the use of cool-beam lamps
Remark 2	A suitable 12V transformer is required for operation
Remark 3	Energy labels in your language are available in the Service Area sub point Download
Suitable for lamps from EEC	C
Suitable for lamps up to EEC	A+
Light distribution type 1	direct

Light distribution      rotationally symmetric  
type 3

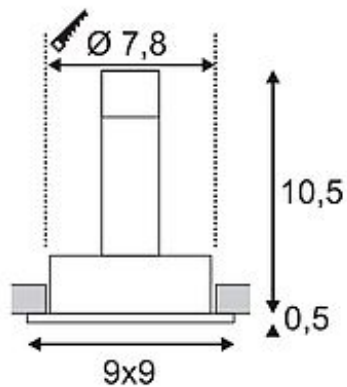

The square low-voltage version of our NEW TRIA downlight series is available in either matt white, matt black or brushed aluminum colour version. The generously chosen rotation and tilt range guarantees the individual orientation of light, whether you choose standard halogen or LED retrofit lamps. To operate the NEW TRIA downlight a suitable low-voltage transformer providing 12V alternating current is required. This luminaire is compatible with bulbs of the energy classes: C - A+