

KALU RECESSED FITTING 3

triple-headed, QPAR111, round, white, max. 225W, incl. clip springs

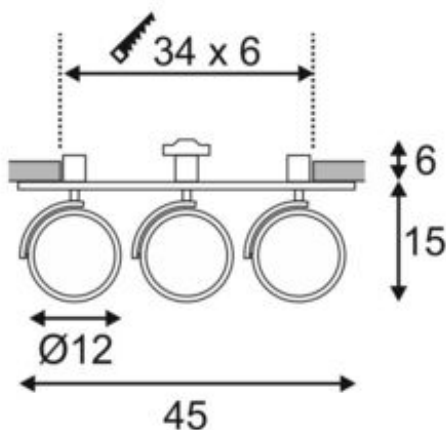
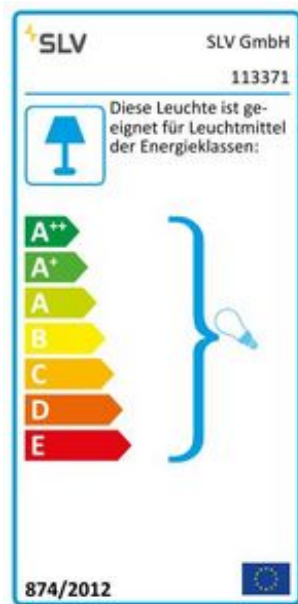

Article number	113371
Light distribution type 1	Direct
Product family	Kalu QPAR111
Feed-in capability	No
LBS code	QPAR111
Lamp	QPAR111
Lampholder / Socket	GU10
Number of light sources	3
Lamp included	No
Installation length	34 cm
Installation width	6 cm
Installation depth	7 cm
Tilt range	90 Degree
Rotation range	350 Degree
Length	45 cm
Width	9 cm
Height	21 cm
Net weight	1.283 kg
Gross weight	1.639 kg
Voltage	230 ~50 Volts
Max. wattage	75 Watt
Protection class	I
Material	Aluminium/steel
Colour	white
Way of mounting	Recessed ceiling / Recessed wall mounting
Energy efficiency class	A++
fastCalcEnabled	No
ranking	200
Catalogue page	BIG WHITE 2017: 512

The pure design of the built-in version of the KALU Series guarantees absolute freedom of adjustment of lamp heads for high-voltage halogen or LED lamps. Single, double, or triple headed versions of the luminaire are available in black, white, or brushed aluminium.