

GU10 SP SQUARE downlight

square, titanium, GU10, max. 50W

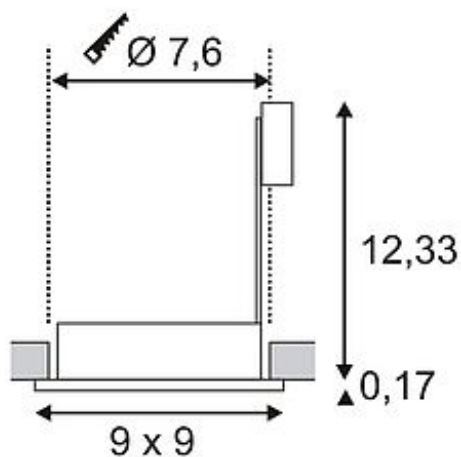

Article number	113217
Catalogue	BIG WHITE 2015, Page 433
Type of lamp	Conventional lamp
Lamp	GU10 230V max. 50W
Lampholder / Socket	GU10
Number of light sources	1
Lamp included	No
Installation diameter	7.5 cm
Installation depth	12.5 cm
Tilt range	90 Degree
Length	9 cm
Width	9 cm
Net weight	0.327 kg
Gross weight	0.363 kg
Voltage	230 Volt
Max. wattage	50 Watt
Protection class	I
Material	steel
Colour	titanium
Way of mounting	recessed ceiling mounting
Remark 1	Energy labels in your language are available in the Service Area sub point Download
Suitable for lamps from EEC	E
Suitable for lamps up to EEC	A++
Light distribution type 1	direct
Light distribution type 3	rotationally symmetric

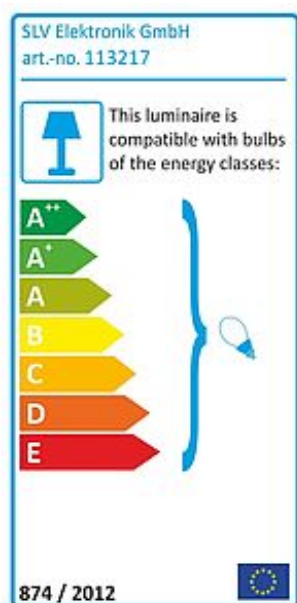

The adjustable high-voltage downlight SQUARE GU10 is available in white, chrome, satin chrome, titanium and silvergrey colour finish and allows individual adjustment of the desired light beam. The electrical connection is made directly via 230V mains supply. This luminaire is compatible with bulbs of the energy classes: E - A++