

HORN-T

recessed fitting, QPAR51, round, matt white, tiltable, max. 50W, incl. clip springs

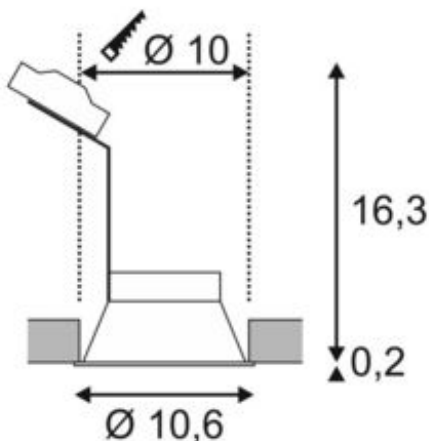

Article number	113141
Light distribution type 1	Direct
Feed-in capability	No
LBS code	QPAR51
Lamp	QPAR51
Lampholder / Socket	GU10
Number of light sources	1
Lamp included	No
Installation diameter	10 cm
Installation depth	16.5 cm
Tilt range	20 Degree
Height	16.5 cm
Diameter	10.6 cm
Net weight	0.246 kg
Gross weight	0.312 kg
Voltage	230 ~50 Volts
Max. wattage	50 Watt
Protection class	II
Material	steel
Colour	matt white
Way of mounting	Recessed ceiling mounting
Energy efficiency class	A++
fastCalcEnabled	No
ranking	200
Catalogue page	BIG WHITE 2017: 470

Tiltable high-voltage recessed fitting from the HORN series. The lamp is installed set to the rear in this luminaire which is made out of steel. This design creates a special appearance while effectively reducing glare. Multi-lamp and low-voltage versions of this series are available.