

NEW TRIA GX10 downlight

square, alu-brushed, max. 35W

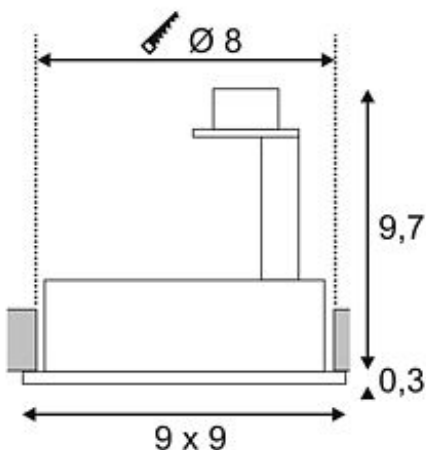

Article number	111451
Type of lamp	Conventional lamp
Lamp	CMH - MR16 35W
Lampholder / Socket	GX10
Number of light sources	1
Lamp included	No
Installation diameter	8 cm
Installation depth	12.5 cm
Tilt range	45 Degree
Rotation range	360 Degree
Length	9 cm
Width	9 cm
Net weight	0.208 kg
Gross weight	0.164 kg
Max. wattage	35 Watt
Protection class	I
Material	aluminium
Colour	aluminium brushed
Way of mounting	recessed ceiling mounting
Remark 1	Additionally you will need an electronic ballast
Remark 2	Energy labels in your language are available in the Service Area sub point Download
Suitable for lamps from EEC	A
Suitable for lamps up to EEC	A
Light distribution type 1	direct
Light distribution type 3	rotationally symmetric

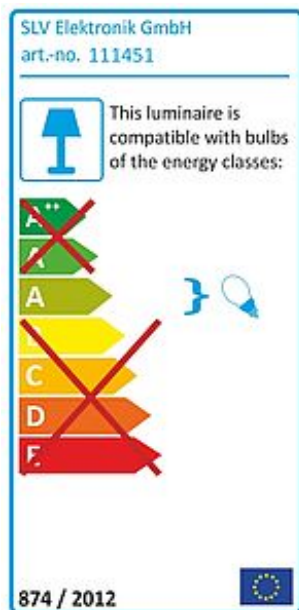

The square CDM version of our NEW TRIA downlight series is available in either matt white or brushed aluminium colour and features a generously chosen rotation and tilt range, which guarantees an individual orientation of the lamps in use. For operation of NEW TRIA GX10 downlights you only need a suitable ballast. This luminaire is compatible with bulbs of the energy classes: A - A