

NEW TRIA II ES111 downlight

rectangular, alu-brushed, GU10 , max. 2x 75W

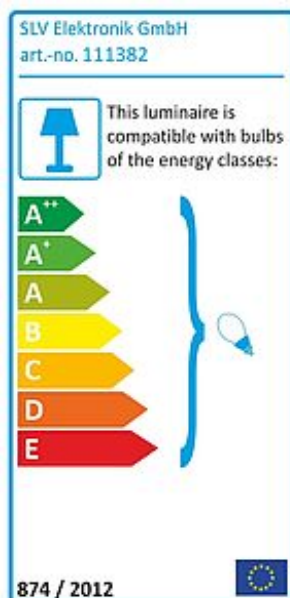

Article number	111382
Catalogue	BIG WHITE 2015, Page 457
Type of lamp	Conventional lamp
Lamp	ES111 230V max. 75W
Lampholder / Socket	GU10
Number of light sources	2
Lamp included	No
Installation length	29.7 cm
Installation width	15.5 cm
Installation depth	12.5 cm
Tilt range	30 Degree
Rotation range	360 Degree
Length	31.5 cm
Width	16.5 cm
Net weight	0.738 kg
Gross weight	0.422 kg
Voltage	230 Volt
Max. wattage	150 Watt
Protection class	I
Material	aluminium
Colour	aluminium brushed
Way of mounting	recessed ceiling mounting
Remark 1	Energy labels in your language are available in the Service Area sub point Download
Suitable for lamps from EEC	E
Suitable for lamps up to EEC	A++
Light distribution type 1	direct
Light distribution type 3	rotationally symmetric

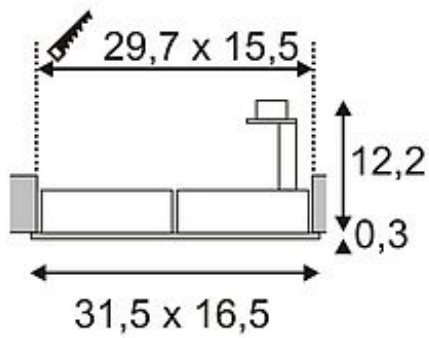

The square ES111 version of our NEW TRIA downlight series is available in brushed aluminum colour version allows to be equipped with two illuminants. The generously chosen rotation and tilt range of the spot guarantees the individual orientation of light, whether your light source of interest is halogen or LED retrofit. NEW TRIA is ready for direct connection to 230V mains supply. This luminaire is compatible with bulbs of the energy classes: E - A++