

NEW TRIA QRB111 downlight

round, alu-brushed, max. 75W

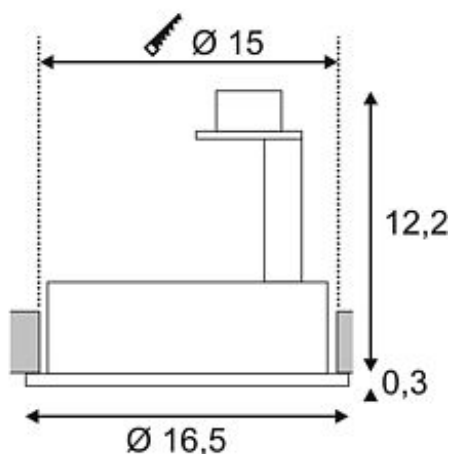
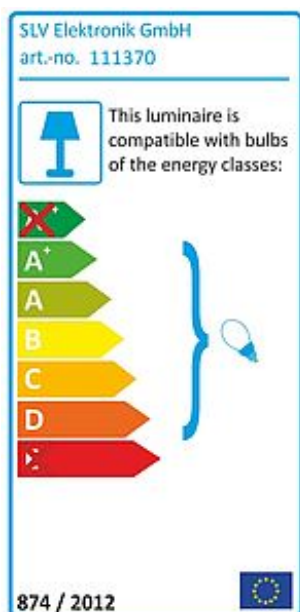

Article number	111370
Catalogue	BIG WHITE 2015, Page 412
Type of lamp	Conventional lamp
Lamp	QRB 111 12V max. 75W
Lampholder / Socket	G53
Number of light sources	1
Lamp included	No
Installation diameter	15 cm
Installation depth	12.5 cm
Tilt range	30 Degree
Rotation range	360 Degree
Diameter	16.5 cm
Net weight	0.287 kg
Gross weight	0.415 kg
Voltage	12 Volt
Max. wattage	75 Watt
Protection class	III
Material	aluminium
Colour	aluminium brushed
Way of mounting	recessed ceiling mounting
Remark 1	Operate with suitable transformer only
Remark 2	Energy labels in your language are available in the Service Area sub point Download
Suitable for lamps from EEC	D
Suitable for lamps up to EEC	A+
Light distribution type 1	direct
Light distribution type 3	rotationally symmetric

The round QRB version of our NEW TRIA downlight series is available in either matt white or brushed aluminum colour version. The generously chosen rotation and tilt range of the spot guarantees the individual orientation of light, whether your light source of interest is halogen or LED retrofit. To operate the NEW TRIA downlights you only need a matching transformer providing 12V alternating current. This luminaire is compatible with bulbs of the energy classes: D - A+