

## NEW TRIA I GU10 downlight

square, alu-brushed, max. 50W

Article number	111361
Catalogue	BIG WHITE 2015, Page 439
Type of lamp	Conventional lamp
Lamp	GU10 230V max. 50W
Lampholder / Socket	GU10
Number of light sources	1
Lamp included	No
Installation diameter	7.8 cm
Installation depth	12.5 cm
Tilt range	30 Degree
Rotation range	360 Degree
Length	9 cm
Width	9 cm
Height	11 cm
Net weight	0.171 kg
Gross weight	0.541 kg
Voltage	230 Volt
Max. wattage	50 Watt
Protection class	II
Material	aluminium
Colour	aluminium brushed
Way of mounting	recessed ceiling mounting
Remark 1	Energy labels in your language are available in the Service Area sub point Download
Suitable for lamps from EEC	E
Suitable for lamps up to EEC	A++
Light distribution type 1	direct
Light distribution type 3	rotationally symmetric

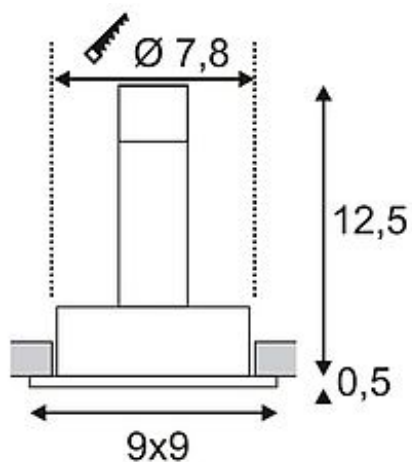

The square high-voltage version of our NEW TRIA downlight series is available in either matt white, matt black or brushed aluminum colour version. The generously chosen rotation and tilt range of the spot guarantees the individual orientation of light, whether your light source of interest is halogen or LED retrofit. To operate the NEW TRIA downlights you only need a matching transformer providing 12V alternating current. This luminaire is compatible with bulbs of the energy classes: E - A++