

TECHNICAL DATA SHEET ART. S.8520SC.19 - MEGAZIP ROUND

Version is available on request

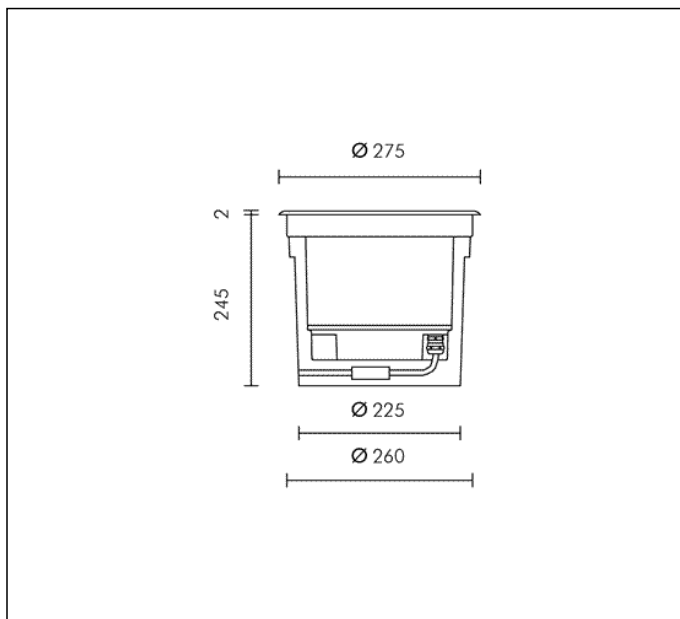

HIT-CRI 35W G12 3300lm
 Rated luminaire luminous flux: 1938lm
 Rated input power: 44W
 Luminaire efficacy: 44lm/W (LOR: 59%)
 Magnetic transformer 230÷240V 50Hz

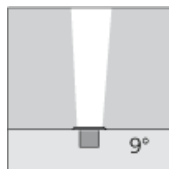

| h(m) | E(lx) 9° | E(lx) 19° |
|------|----------|-----------|
| 25 | 1 | 0 |
| 20 | 2 | 0 |
| 15 | 4 | 1 |
| 10 | 10 | 6 |
| 5 | 57 | 23 |

0.2 m 0 (m) 0 (m)



PRODUCT TYPE

Inground walk over fitting. Recessing depth 240 mm. IP rating IP 67

MATERIAL CHARACTERISTICS

"Copper Free" Aluminium die cast housing in EN AB-44100 with high resistance against corrosion. Stone wash surface treatment prior to painting process. 2 mm thick front trim in Stainless Steel - Grade AISI 316L with 2,5-3% molybdenum content. A4 grade Stainless Steel screws with 2,5-3% molybdenum content which increases the resistance against corrosion. Pre treated Silicone Gaskets. Painting Process : 3 Step Process

1) Surface treatment with BONDERITE. A heavy metal free chemical surface treatment containing ceramic nano particles giving a cohesive, inorganic and highly dense protective coating. 2) PRE POLYMERIZATION a process of introducing an epoxy primer with excellent characteristics to the paint which also offers very high resistance to oxidation due to its Zinc content. 3) POLYMERIZATION a process with the application of polyester powder with high resistance against UV rays and harsh weather conditions. Resistance test protection for Marine applications for 1200h. Mechanical resistance IK 09 Maximum load capacity 1000 Kg

LIGHTING PERFORMANCE

Reflector in 99.98% pure anodized aluminium . Toughened semiacid-etched glass 12mm thick. Lamp adjustable ±15° position. LOR 59%

LOW SURFACE TEMPERATURE

Surface temperature of glass 62°C (Ta 25°C)

RECESSING BOX

Polypropylene recessing box with cable entry on all 4 sides also allows: 1) Easy wiring; 2) Cable management for IP68 fast connector; 3) Easy access to the fitting for maintenance purposes.

WIRING

Supply 0.5m cable section type H07RN-F secured by cable gland PG 13.5 (Ø 6÷12 mm) and sealed with B component epoxy resin, wired internally protected by silicon sheaths. Front re-lamping without removing the complete fitting . Isolation: CLASS I . Available colours: Stainless steel (cod.19). Weight: 6.4 Kg Glow Wire test: 850°C

Lamp included.

This luminaire is compatible with bulbs of the energy classes: A+. The luminaire is sold with a bulb of the energy class: A+ (Regulation UE 874/2012).

TECHNICAL DATA SHEET ART. S.8520SC.19 - MEGAZIP ROUND INCLUDED ACCESSOIRES



FAST CONNECTOR INCLUDED

ACCESSORIES



S.5505

ANTI-GLARE SHIELD

Only for HIT-CRI 35W/70W G12 versions with 6°/16° reflector and semi-acid etched glass.



CAS8510



CAS8510