

TECHNICAL DATA SHEET ART. S.7016WSC - CONTINUOUS LINE 0,5m FULL GLASS

Version is available on request

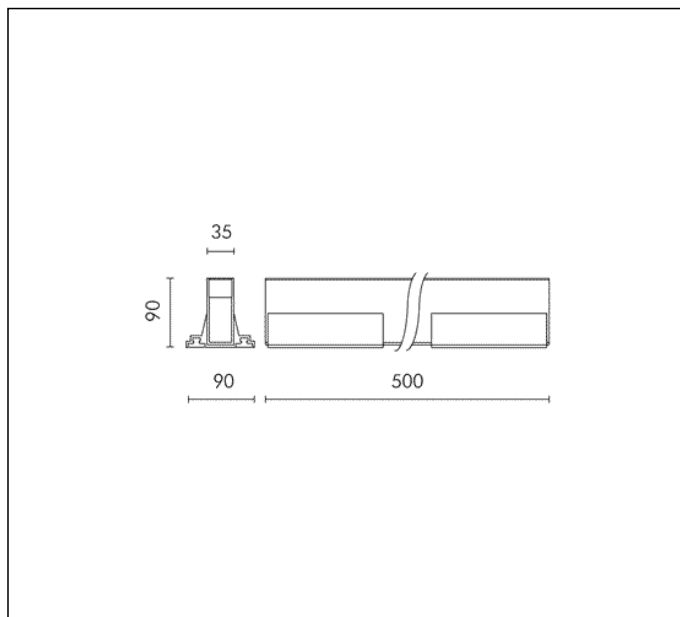

MODULES LED 3000K 24V 360lm CRI 80

Rated luminaire luminous flux: 165lm

Rated input power: 3.5W

Luminaire efficacy: 47lm/W

Without transformer

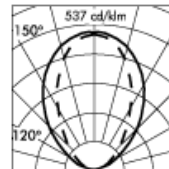
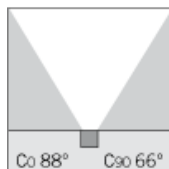

h(m)	E(lx)			
2.5	0.5	0.5	0.5	0.0
2.0	1.0	1.0	1.0	0.5
1.5	2.0	2.0	1.5	1.0
1.0	8.0	6.0	3.5	2.0
0.5	45	25	7.0	2.5
0.1 m	0	0.3	0.6	0.9 (m)



PRODUCT TYPE

Inground walk over fitting. Recessing depth 90 mm. IP rating IP 67

MATERIAL CHARACTERISTICS

Fixing base and recessing box in extruded anodized EN AW-6060 aluminium housing (copper free) with high corrosion resistance. Mechanical resistance IK 09 Maximum load capacity 500 Kg

LIGHTING PERFORMANCE

Extruded polycarbonate diffuser 3mm thick. Lamp fixed position. LOR --

LOW SURFACE TEMPERATURE

Surface temperature of diffusor 39°C (Ta 25°C)

RECESSING BOX

The housing is realized in aluminium and it is supplied with a protective cover resistant to tearing, which is to be removed only after cementing the housing flush to the pavement, just before the final installation of the fitting.

WIRING

CONTINUOUS LINE is equipped with to-be-fixed supports to perfectly align additional fittings and provide easy installation. Using this simple system to join the housing and supports also assists in levelling the housings in a CONTINUOUS LINE. It is possible to level the fitting using screws. The wiring is external to the housing. Luminaire hard wired with 0,15m H05RN-F single cable. The result is a continuous line of light. Isolation: CLASS III. Available colours: Anodized aluminium (cod.13). Weight: 5.73 Kg Glow Wire test: 850°C

Lamp included.

LINEA CONTINUA PATENTED 2013

This luminaire contains built-in LED modules with energy class: A, A+, A++. In case of damage or malfunction please contact the manufacturer to receive additional instructions on how to replace and relative spare parts to order. The LED modules cannot be handled in the luminaire by the end user (Regulation UE 874/2012).

LED circuit boards are engineered accordingly to actual Lumen Maintenance regulation (LM80) and Technical Memorandum (TM21) where uniformity and quality of light is 50.000 hours referred to L70 B20 Ta 25°C.

Lifecycle refers to LED circuit boards only, all others components of the luminaire are excluded.

TECHNICAL DATA SHEET ART. S.7016WSC - CONTINUOUS LINE 0,5m FULL GLASS ACCESSORIES



S.3407
REMOTE POWER SUPPLY 100W IP66
for monochromatic LED 100W 240V/24V DC.
IP66
The Total power of all connected luminaires may not be higher than the power of the driver.
Dimensions 210mm x70mm x40mm



S.3420
REMOTE BOX NOT DIMMABLE 100W IP55
POWER SUPPLY
240V/24V d.c.
5 Exit
Dimensions 260x260x100mm
The Total power of all connected luminaires may not be higher than the power of the driver.
IP55



S.3402
REMOTE POWER SUPPLY DIMMABLE 40W IP67
Dimmable 1-10V for monochromatic LED
40W 240V/24V DC
IP67
The Total power of all connected luminaires may not be higher than the power of the driver.
Dimensions 150x53x35mm



S.3428
BOX WITH DALI REMOTE POWER SUPPLY
50W 230V/24V d.c.
Dimensions 260mm x260mm x100mm
IP55



S.3429
BOX WITH DALI REMOTE POWER SUPPLY
100W 230V/24V d.c.
Dimensions 260mm x260mm x100mm
IP55



CAS7005