

TECHNICAL DATA SHEET ART. S.6070W - MINIBLINKER

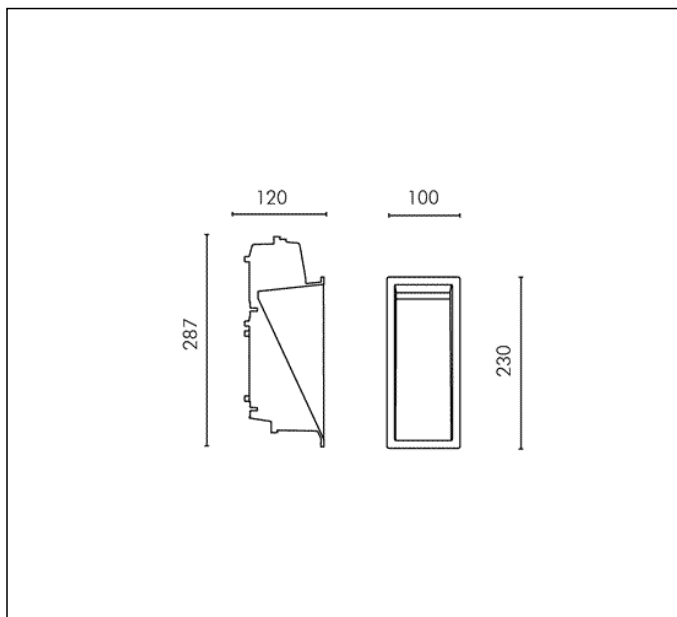

1 MODULES LED COB 3000K 230V 1565lm CRI 90 MacAdam step 3

Rated luminaire luminous flux: 281lm

Rated input power: 17W

Luminaire efficacy: 17lm/W

Electronic ballast 220÷240V 0/50/60Hz

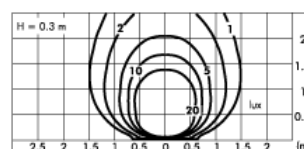
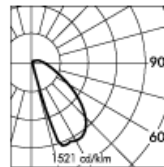
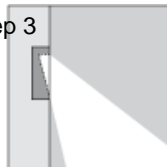

Fixture available with integral DALI driver on request with surcharge.

PRODUCT TYPE

Wall mounted luminaire. IP rating IP 65

MATERIAL CHARACTERISTICS

Aluminium die cast housing in EN AB-47100 (low copper content) with high resistance against corrosion. Stone wash surface treatment prior to painting process. A4 grade Stainless Steel screws with 2,5-3% molybdenum content which increases the resistance against corrosion. Silicone gaskets. Painting Process : 3 Step Process

1) Surface treatment with BONDERITE. A heavy metal free chemical surface treatment containing ceramic nano particles giving a cohesive, inorganic and highly dense protective coating. 2) PRE POLYMERIZATION a process of introducing an epoxy primer with excellent characteristics to the paint which also offers very high resistance to oxidation due to its Zinc content. 3) POLYMERIZATION a process with the application of polyester powder with high resistance against UV rays and harsh weather conditions. Resistance test protection for Marine applications for 1200h. Mechanical resistance IK 06

LIGHTING PERFORMANCE

Reflector in 99.98% pure anodized aluminium . Acid-etched toughened glass 4 mm thick. LOR --

INSTALLATION AND MAINTENANCE

The recessing box is provided with support ribs that make it crush-proof during installation; the ribs are molded to the recessing box and cannot fall out before installation. The ribs must be removed before the installation of the luminaire. The lamp body is secured to the recessing box through stainless steel clips; the electric components are protected by a covering reflector that houses the light source.

WIRING

Single cable entry . Isolation: CLASS I . Available colours: Aluminium grey (cod.14). Weight: 1.3 Kg Glow Wire test: --

L.E.D circuit included.

BLINKER REGISTERED DESIGN

This luminaire contains built-in LED modules with energy class: A, A+, A++. In case of damage or malfunction please contact the manufacturer to receive additional instructions on how to replace and relative spare parts to order. The LED modules cannot be handled in the luminaire by the end user (Regulation UE 874/2012).

LED circuit boards are engineered accordingly to actual Lumen Maintenance regulation (LM80) and Technical Memorandum (TM21) where uniformity and quality of light is 50.000 hours referred to L70 B20 Ta 25°C.

Lifecycle refers to LED circuit boards only, all others components of the luminaire are excluded.

EMERGENCY VERSIONS

The fittings operates both on AC (50/60Hz) and DC (0Hz) voltage.

TECHNICAL DATA SHEET ART. S.6070W - MINIBLINKER ACCESSORIES



S.6073
RECESSING BOX
110 x 300 mm
Depth 130 mm

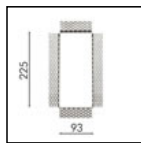

S.6074
MASK FOR PLASTER BOARD WALLS
Hole 95 x 225 mm