

## TECHNICAL DATA SHEET ART. S.5982W - LINEAR FRAME LONG

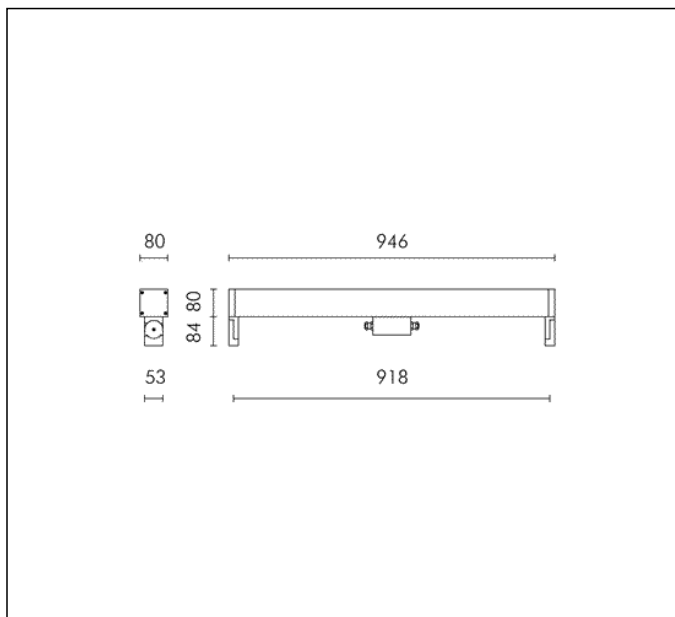
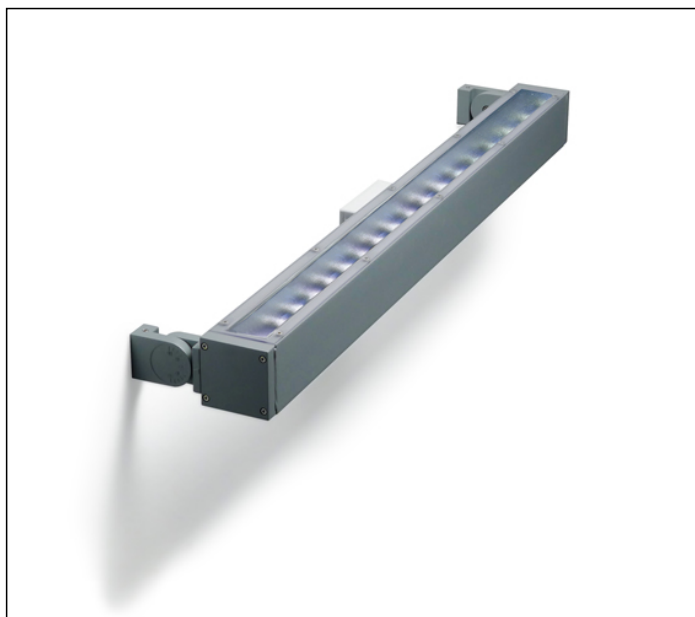

18 MODULES LED 3000K 230V 2552lm 27W CRI 90 MacAdam step 3

Rated luminaire luminous flux: 2058lm

Rated input power: 33W

Luminaire efficacy: 62lm/W

Electronic ballast 220÷240V 0/50/60Hz

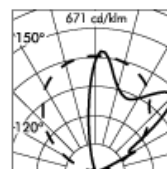
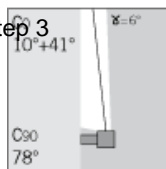

h(m)	E(lx)		
5	2	1	1
4	3	3	2
3	7	6	3
2	24	15	6
1	138	41	6
	0	1	2
			3 (m)



Fixture available with integral DALI driver on request with surcharge.

### PRODUCT TYPE

Wall mounted luminaire. IP rating IP 65

### MATERIAL CHARACTERISTICS

Die-cast EN AB-47100 and extruded EN AW-6060 aluminium housing with high corrosion resistance. Stone wash surface treatment prior to painting process. A4 grade Stainless Steel screws with 2,5-3% molybdenum content which increases the resistance against corrosion. Pre treated Silicone Gaskets. Painting Process : 3 Step Process

1) Surface treatment with BONDERITE. A heavy metal free chemical surface treatment containing ceramic nano particles giving a cohesive, inorganic and highly dense protective coating. 2) PRE POLYMERIZATION a process of introducing an epoxy primer with excellent characteristics to the paint which also offers very high resistance to oxidation due to its Zinc content. 3) POLYMERIZATION a process with the application of polyester powder with high resistance against UV rays and harsh weather conditions. Resistance test protection for Marine applications for 1200h. Mechanical resistance IK 09 Maximum load capacity --

### LIGHTING PERFORMANCE

Reflector in 99.98% pure anodized aluminium . transparent polycarbonate diffuser 10 mm thick. Lamp fixed position. LOR -- Compact electronic ballast to guarantee better lamp stability, lifetime and reduced energy consumption.

### INSTALLATION AND MAINTENANCE

To install the luminaire, attach two aluminium mounting brackets to the wall. Use two dowels to fix the unit, which is hung on the mounting brackets. The electric cable assembly block is situated on the rear of the device. Through wiring is possible with M20 (Ø 7÷13 mm) cable glands.

### WIRING

Double cable entries for M20 cable glands. Isolation: CLASS II . Available colours: Aluminium grey (cod.14). Weight: 5.8 Kg Glow Wire test: 750°C

L.E.D circuit included.

This luminaire contains built-in LED modules with energy class: A, A+, A++. In case of damage or malfunction please contact the manufacturer to receive additional instructions on how to replace and relative spare parts to order. The LED modules cannot be handled in the luminaire by the end user (Regulation UE 874/2012).

LED circuit boards are engineered accordingly to actual Lumen Maintenance regulation (LM80) and Technical Memorandum (TM21) where uniformity and quality of light is 50.000 hours referred to L70 B20 Ta 25°C.

Lifecycle refers to LED circuit boards only, all others components of the luminaire are excluded.

### EMERGENCY VERSIONS

The fittings operates both on AC ( 50/60Hz ) and DC ( 0Hz ) voltage.