

TECHNICAL DATA SHEET ART. S.5981 - LINEAR FRAME LONG

Available until 31/12/2017 but subject to stock levels

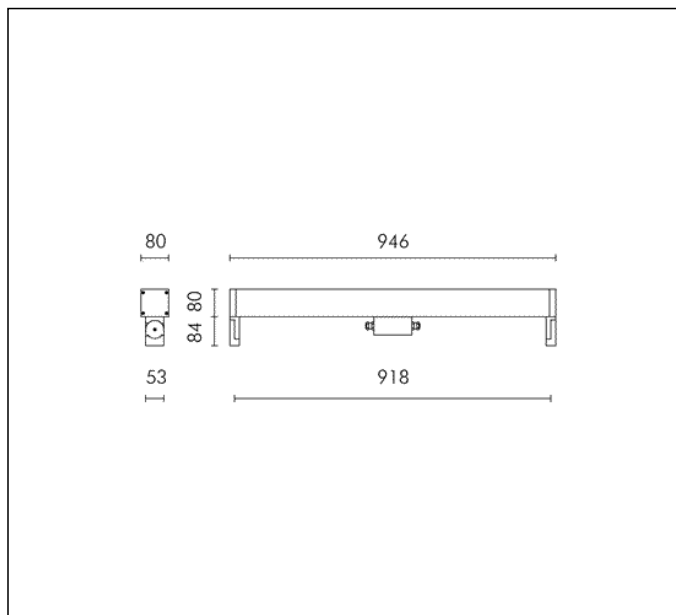

T16 39W G5 3500lm
 Rated luminaire luminous flux: 875lm
 Rated input power: 42.5W
 Luminaire efficacy: 21lm/W (LOR: 25%)
 Electronic ballast 220÷240V 50/60Hz

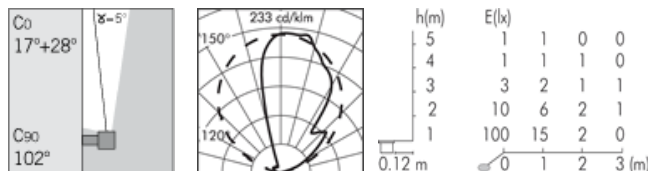

PRODUCT TYPE

Wall mounted luminaire. IP rating IP 65

MATERIAL CHARACTERISTICS

Die-cast EN AB-47100 and extruded EN AW-6060 aluminium housing with high corrosion resistance. Stone wash surface treatment prior to painting process. A4 grade Stainless Steel screws with 2,5-3% molybdenum content which increases the resistance against corrosion. Pre treated Silicone Gaskets. Painting Process : 3 Step Process

1) Surface treatment with BONDERITE. A heavy metal free chemical surface treatment containing ceramic nano particles giving a cohesive, inorganic and highly dense protective coating. 2) PRE POLYMERIZATION a process of introducing an epoxy primer with excellent characteristics to the paint which also offers very high resistance to oxidation due to its Zinc content. 3) POLYMERIZATION a process with the application of polyester powder with high resistance against UV rays and harsh weather conditions. Resistance test protection for Marine applications for 1200h. Mechanical resistance IK 09 Maximum load capacity --

LIGHTING PERFORMANCE

Reflector in 99.98% pure anodized aluminium . transparent polycarbonate diffuser 10 mm thick. Lamp fixed position. LOR 25% Compact electronic ballast to guarantee better lamp stability, lifetime and reduced energy consumption.

INSTALLATION AND MAINTENANCE

To install the luminaire, attach two aluminium mounting brackets to the wall. Use two dowels to fix the unit, which is hung on the mounting brackets. The electric cable assembly block is situated on the rear of the device. Through wiring is possible with M20 (Ø 7÷13 mm) cable glands.

WIRING

Double cable entries for M20 cable glands. Isolation: CLASS II . Available colours: Aluminium grey (cod.14). Weight: 5.2 Kg Glow Wire test: 750°C

Lamp included.

This luminaire is compatible with bulbs of the energy classes: A+. The luminaire is sold with a bulb of the energy class: A+ (Regulation UE 874/2012).

EMERGENCY VERSIONS

On request the fittings could be provided with electronic ballast which operate both on AC (50/60Hz), both on DC (0Hz) voltage.