

TECHNICAL DATA SHEET ART. S.4526 - MEGABRIQUE RECTANGULAR

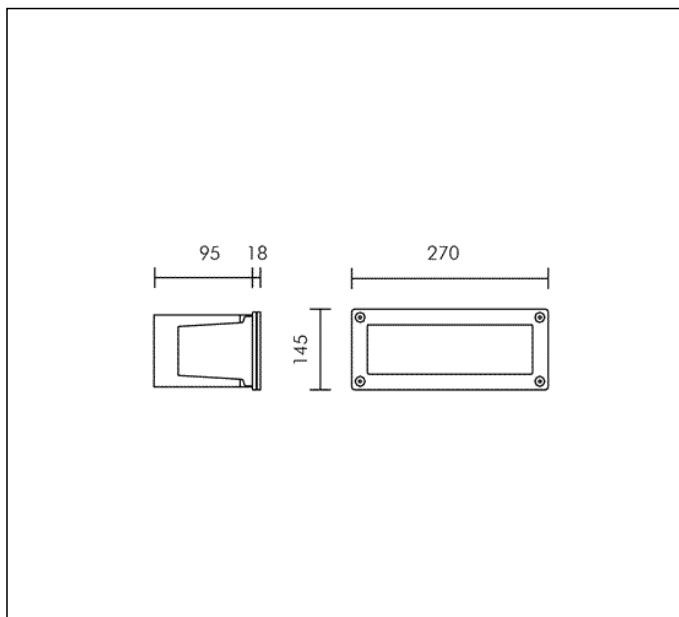

TC-DEL 26W G24q-3 1800lm
 Rated luminaire luminous flux: 504lm
 Rated input power: 31W
 Luminaire efficacy: 16lm/W (LOR: 28%)
 Electronic ballast 230÷240V 50Hz

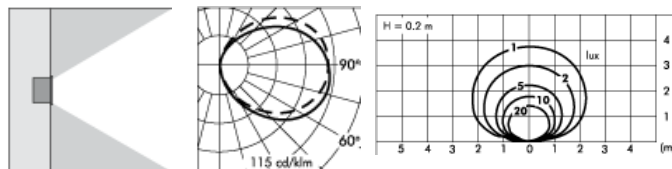

PRODUCT TYPE

Wall mounted luminaire. IP rating IP 65

MATERIAL CHARACTERISTICS

Aluminium die cast housing in EN AB-47100 (low copper content) and extruded EN AW-6060 with high resistance against corrosion. Stone wash surface treatment prior to painting process. A4 grade Stainless Steel screws with 2,5-3% molybdenum content which increases the resistance against corrosion. EPDM gaskets. Painting Process : 3 Step Process

1) Surface treatment with BONDERITE. A heavy metal free chemical surface treatment containing ceramic nano particles giving a cohesive, inorganic and highly dense protective coating. 2) PRE POLYMERIZATION a process of introducing an epoxy primer with excellent characteristics to the paint which also offers very high resistance to oxidation due to its Zinc content. 3) POLYMERIZATION a process with the application of polyester powder with high resistance against UV rays and harsh weather conditions. Resistance test protection for Marine applications for 1200h. Mechanical resistance IK 06

LIGHTING PERFORMANCE

Reflector in 99.98% pure anodized aluminium . Opal toughened glass diffuser. LOR 28%

INSTALLATION AND MAINTENANCE

Installation is simple with polypropylene recessing box. Appropriate plastic supports reinforce the centre of the structure. This strategy prevents buckling during the concrete wall construction phase. The luminaires are fixed in the recessing box by stainless steel screws. The reeded glass lightly conceals the view inside the luminaire. The glass is safely protected against blows or vandalism. The trim and the grill hold the glass diffuser in place while covering the rim of the recessing box and the holes. This assures that wall imperfections remain hidden.

WIRING

Double cable entries. Isolation: CLASS I . Available colours: Aluminium grey (cod.14). Weight: 2.2 Kg Glow Wire test: 850°C

Lamp not included.

This luminaire is compatible with bulbs of the energy classes: A (Regulation UE 874/2012).

TECHNICAL DATA SHEET ART. S.4526 - MEGABRIQUE RECTANGULAR ACCESSORIES



S.4523
RECESSING BOX RECTANGULAR
263 x 135 mm.
Width 95 mm.