

TECHNICAL DATA SHEET ART. S.3761W - MINITECHNO RECTANGULAR FLOOD

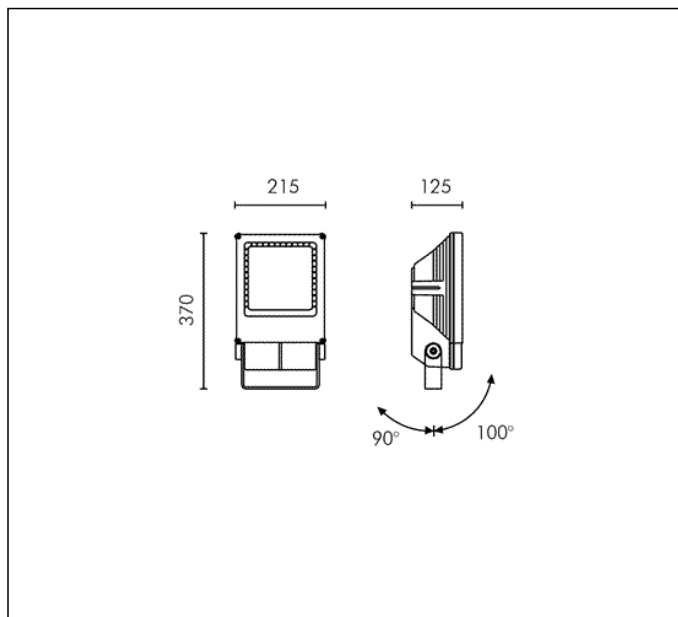

1 MODULES LED COB 3000K 3300lm CRI 90 MacAdam step 3
 Rated luminaire luminous flux: 2740lm
 Rated input power: 36W
 Luminaire efficacy: 76lm/W
 Electronic ballast 220÷240V 0/50/60Hz

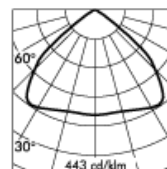
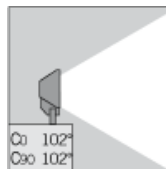

h(m)	102°x102°	
	∅(m)	E(lk)
2	4.90	280
4	9.81	70
6	14.71	31
8	19.62	18
10	24.52	11

CE □ ⚡ IP 65 A A+ A++

Fixture available with integral DALI driver on request with surcharge.

PRODUCT TYPE

Projector. IP rating IP 65

MATERIAL CHARACTERISTICS

Aluminium die cast housing in EN AB-47100 (low copper content) with high resistance against corrosion. Stone wash surface treatment prior to painting process. A4 grade Stainless Steel screws with 2,5-3% molybdenum content which increases the resistance against corrosion. Pre treated Silicone Gaskets. Painting Process : 3 Step Process

1) Surface treatment with BONDERITE. A heavy metal free chemical surface treatment containing ceramic nano particles giving a cohesive, inorganic and highly dense protective coating. 2) PRE POLYMERIZATION a process of introducing an epoxy primer with excellent characteristics to the paint which also offers very high resistance to oxidation due to its Zinc content. 3) POLYMERIZATION a process with the application of polyester powder with high resistance against UV rays and harsh weather conditions. Resistance test protection for Marine applications for 1200h. 4 mm thick tempered glass diffuser. Mechanical resistance IK 08 Maximum load capacity --

LIGHTING PERFORMANCE

The lathed anodized reflector is composed of 99,98% pure anodized aluminium with a bright polish finish. LOR --

INSTALLATION AND MAINTENANCE

The projector is supplied with graduated ferrules on both sides of the fitting.

WIRING

Double cable entry with PG16 (∅ 10÷14 mm) cable gland. Isolation: CLASS II . Available colours: Aluminium grey (cod.14). Weight: 5.4 Kg Glow Wire test: 850°C

Lamp included.

This luminaire contains built-in LED modules with energy class: A, A+, A++. In case of damage or malfunction please contact the manufacturer to receive additional instructions on how to replace and relative spare parts to order. The LED modules cannot be handled in the luminaire by the end user (Regulation UE 874/2012).

LED circuit boards are engineered accordingly to actual Lumen Maintenance regulation (LM80) and Technical Memorandum (TM21) where uniformity and quality of light is 50.000 hours referred to L70 B20 Ta 25°C.

Lifecycle refers to LED circuit boards only, all others components of the luminaire are excluded.

TECHNICAL DATA SHEET ART. S.3761W - MINITECHNO RECTANGULAR FLOOD ACCESSORIES



S.3781 VISOR

In painted steel with die-cast aluminium ring holder. To be installed instead of the aluminium ring holder.

Further information

FIXING BASE

