

TECHNICAL DATA SHEET ART. S.3696.19 - POOL SPOT

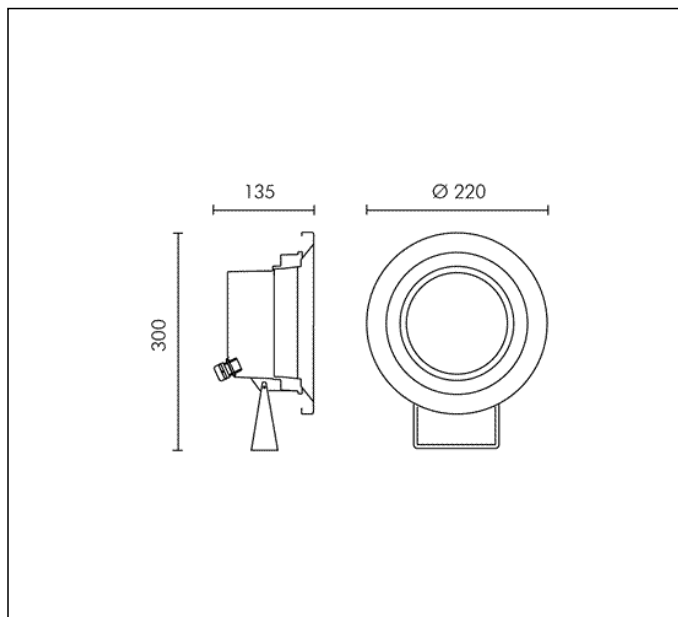

12 MODULES LED 6000K 24V 3340lm CRI 70

Rated luminaire luminous flux: 1489lm

Rated input power: 34W

Luminaire efficacy: 44lm/W

Without transformer

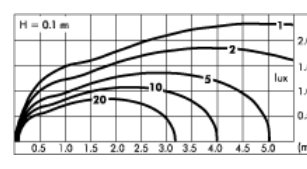
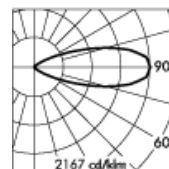
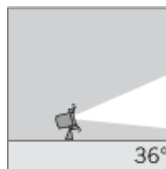

CE III IP 68 - 3m A A+ A++

PRODUCT TYPE

Submersion luminaire. IP rating IP 68

MATERIAL CHARACTERISTICS

Talc-filled technopolymer housing. Marine grade stainless steel AISI 316L front trim 2 mm thick. A4 grade Stainless Steel screws with 2,5-3% molybdenum content which increases the resistance against corrosion. Toughened transparent glass 4mm thick for MICROPOOL SPOT, 8mm MINIPOOL SPOT and POOL SPOT. Mechanical resistance IK 10 Silicone gaskets.

LIGHTING PERFORMANCE

Lamp fixed position. LOR --

WIRING

POOL SPOT requires a FLANGE accessory to anchor the fitting to the bottom of pools or fountains. The stainless steel flange is supplied with fastening screws, both for fixing the fitting to the flange and for the anchorage to the bottom of the pool. Should the fixation with screws be impossible, the weight of the accessory still allows to keep the luminaire sitting on the bottom of the pool. Single cable entry with M20 brass cable gland. Luminaire hard wired with 6 m. cable (2 x 1.5 mm²) cable type H07RN8-F for MICROPOOL, 6 m. cable (2 x 2,5 mm²) cable type H07RN8-F for MINIPOOL and 8 m. cable (2 x 2,5mm²) cable type H07RN8-F for POOL closed by cable gland and sealed with B component epoxy resin, wired internally protected by silicon sheaths. MICROPOOL, MINIPOOL and POOL with cold white led work also with traditional systems 12V CA (proper to substitute existing lamps for swimming pool with magnetic transformer 230V/12V CA). Isolation: CLASS III . Available colours: Stainless steel (cod.19). Weight: 3.3 Kg

Lamp included.

Not suitable to install outside the water.

The luminaire cannot be installed out of the water

Not suitable for immersion in sea water.

POOL REGISTERED DESIGN

This luminaire contains built-in LED modules with energy class: A, A+, A++. In case of damage or malfunction please contact the manufacturer to receive additional instructions on how to replace and relative spare parts to order. The LED modules cannot be handled in the luminaire by the end user (Regulation UE 874/2012).

LED circuit boards are engineered accordingly to actual Lumen Maintenance regulation (LM80) and Technical Memorandum (TM21) where uniformity and quality of light is 50.000 hours referred to L70 B20 Ta 25°C.

Lifecycle refers to LED circuit boards only, all others components of the luminaire are excluded.

TECHNICAL DATA SHEET ART. S.3696.19 - POOL SPOT ACCESSORIES



**S.3672
FLANGE**
Fixation base plate installation.
Kg 3,5



**S.3665
JUNCTION BOX WITH POWER SUPPLY**
70W 240V/24V c.c.
IP65 power supply for: N°4 Micropool LED** o N°3 Minipool LED* or N°2 Pool LED
maximum load capacity 500Kg
Dimensions 300mm x300mm x230mm
** = require 2 x S.3670 additional cable gland
* = require 1 x S.3670 additional cable gland



**S.3670
1 ADDITIONAL CABLE GLAND**
Required for the connection of over 2 luminaires to the junction box /power supply.



**S.3660
JUNCTION BOX IP65***
Junction box with cable glands for 3 cables IN (possibility of 3 more cables IN with S.3670 accessories)
Maximum load capacity 500Kg
Dimensions 300mm x300mm x230mm

Further information

FIXING BASE

