

TECHNICAL DATA SHEET ART. S.2910N - SMOOTH SINGLE EMISSION

Version is available on request

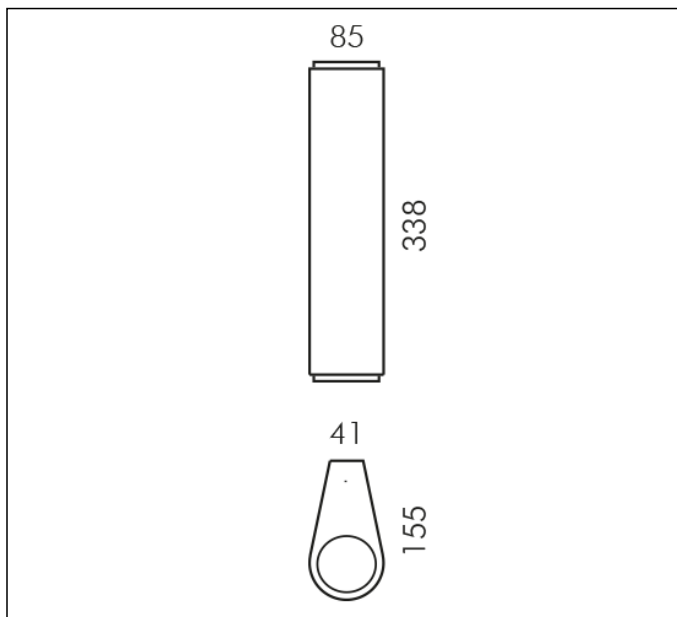

1 MODULES LED COB 4000K 230V 1453lm CRI 90 MacAdam step 3

Rated luminaire luminous flux: 1126lm

Rated input power: 13.5W

Luminaire efficacy: 83lm/W

Electronic ballast 220÷240V 50/60Hz

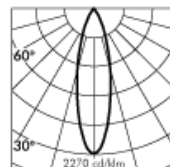
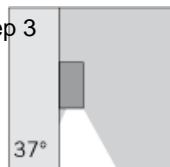

h(m)	37° Ø(m)	3000K E(lx)
2	1.32	614
4	2.65	153
6	3.97	68
8	5.29	38
10	6.61	25

* Photometric measured using WHITE LED 3000K



Fixture available with integral DALI driver on request with surcharge.

PRODUCT TYPE

Wall mounted luminaire. IP rating IP 65

MATERIAL CHARACTERISTICS

Aluminium die cast housing in EN AB-47100 (low copper content) and extruded EN AW-6060 with high resistance against corrosion. Stone wash surface treatment prior to painting process. A4 grade Stainless Steel screws with 2,5-3% molybdenum content which increases the resistance against corrosion. Silicone gaskets. Painting Process : 3 Step Process

1) Surface treatment with BONDERITE. A heavy metal free chemical surface treatment containing ceramic nano particles giving a cohesive, inorganic and highly dense protective coating. 2) PRE POLYMERIZATION a process of introducing an epoxy primer with excellent characteristics to the paint which also offers very high resistance to oxidation due to its Zinc content. 3) POLYMERIZATION a process with the application of polyester powder with high resistance against UV rays and harsh weather conditions. Resistance test protection for Marine applications for 1200h. Mechanical resistance IK 06

LIGHTING PERFORMANCE

Toughened semiacid-etched decorative glass diffuser 8mm thick. Uniform distribution: The balance between the source, the reflector and the protruding semi-frosted glass creates a soft and uniform light distribution. Clean design: The continuous surface of the cover embraces, as a curved sheet, the internal luminaire. Junctions, screws and fastening elements are totally hidden to obtain a completely smooth shape and a clean design. LOR --

WIRING

Luminaire hard wired with single neoprene cable 20cm (MINISMOOTH and SMOOTH). Luminaire suitable for double grommets (MEGASMOOTH). Isolation: CLASS II . Available colours: White (cod.01), Aluminium grey (cod.14). Weight: Kg Glow Wire test: --

L.E.D circuit included.

SMOOTH PATENT PENDING, REGISTERED DESIGN

This luminaire contains built-in LED modules with energy class: A, A+, A++. In case of damage or malfunction please contact the manufacturer to receive additional instructions on how to replace and relative spare parts to order. The LED modules cannot be handled in the luminaire by the end user (Regulation UE 874/2012).

LED circuit boards are engineered accordingly to actual Lumen Maintenance regulation (LM80) and Technical Memorandum (TM21) where uniformity and quality of light is 50.000 hours referred to L70 B20 Ta 25°C.

Lifecycle refers to LED circuit boards only, all others components of the luminaire are excluded.