

Fabbian

50 via Santa Brigida
31020 Castelmio di Resana
Treviso, Italy Tel +39 0423 4848 fax +39 423 484395
fabbian@fabbian.com www.fabbian.com

BINARIO

(*) D39A03 (***) D39A05 (***) D39A07

I

ATTENZIONE: LA SICUREZZA DELL'APPARECCHIO È GARANTITA SOLO CON L'USO APPROPRIATO DELLE SEGUENTI ISTRUZIONI. CONSERVARLE CON CURA.
AVVERTENZE

Prima di eseguire qualsiasi tipo di operazione togliere la tensione in rete.
Fare attenzione a non superare il Max di watt indicati per l'apparecchio.
L'apparecchio non può essere usato in ambienti umidi o all'esterno.
Mai coprire l'apparecchio durante il funzionamento.

Se il cavo flessibile esterno di questo apparecchio viene danneggiato, deve essere sostituito dal costruttore o dal suo servizio di assistenza, o da personale qualificato equivalente, al fine di evitare pericoli.

Potenza massima della lampada.	(*) 2x 39W	(**) 2x 54W	(***) 2x 80W
Attacco lampada.	G5	G5	G5
Tipo lampada.	T5		
Apparecchio classe I			
Classe di protezione.	IP20		
Adatto al montaggio su superfici normalmente infiammabili.	▽		

GB

ATTENTION: THE SAFETY OF THE APPLIANCE IS GUARANTEED ONLY IF IT IS PROPERLY USED, ACCORDING TO THE FOLLOWING INSTRUCTIONS, WHICH ARE TO BE KEPT.

WARNING

Always disconnect the power supply before installing or performing any maintenance operations.
Make attention of not exceeding the maximum watt indicated on the appliance.
The appliance may not be used in humid or external environments.
Never cover the appliance while in function.

If the external flexible cable or cord of this luminaire is damaged, it shall be exclusively replaced by the manufacturer or his service agent or a similar qualified person in order to avoid a hazard.

Capacity of bulb.	(*) 2x 39W	(**) 2x 54W	(***) 2x 80W
Type of lampholder.	G5	G5	G5
Type of bulb.	T5		
Appliance in class I			
Protection class.	IP20		
Adaptable for mounting onto surfaces normally inflammable.	▽		

D

ACHTUNG: DIE SICHERHEIT DIESES BELEUCHTUNGSKÖRPERS WIRD NUR DURCH DIE KORREKTE ANWENDUNG DER NACHSTEHENDEN ANWEISUNGEN GEWÄHRLEISTET. DIESE ÜSSEN DAHER SORGFÄLTIG AUFBEWAHRT WERDEN.

WICHTIGE HINWEISE

Der Beleuchtungskörper darf nicht in feuchten Räumen bzw. im Freien eingesetzt werden.
Bevor irgendwelche Arbeitsgänge ausgeführt werden, muß die Stromversorgung unterbrochen.
Achten Sie darauf, daß die auf dem Beleuchtungskörper angegebene maximale Wattzahl nicht überschritten wird.
Den Beleuchtungskörper während dem Betrieb nicht abdecken.

If the external flexible cable or cord of this luminaire is damaged, it shall be exclusively replaced by the manufacturer or his service agent or a similar qualified person in order to avoid a hazard.

Leistung der Gluehbirne.	(*) 2x 39W	(**) 2x 54W	(***) 2x 80W
Anschluss.	G5	G5	G5
Typ der Gluehbirne.	T5		
Geratet der Klasse I			
Schutzklasse	IP20		
Das Geratet eignet sich fuer die Montage auf normal entflammabaren Oberflächen	▽		

RU

ВНИМАНИЕ: БЕЗОПАСНОСТЬ ОСВЕТИТЕЛЬНОГО ПРИБОРА ГАРАНТИРОВАНА ТОЛЬКО ПРИ УСЛОВИИ ЕГО ЭКСПЛУАТАЦИИ В СООТВЕТСТВИИ С ПРИВЕДЕННЫМИ НИЖЕ ИНСТРУКЦИЯМИ, КОТОРЫЕ НЕОБХОДИМО СОХРАНИТЬ.

ВНИМАНИЕ:

Осветительный прибор не может быть использован во влажных помещениях или на улице.
Перед выполнением любой операции с осветительным прибором отключить напряжение в сети.
Не превышать максимально допустимую мощность, указанную для данного осветительного прибора.
Никогда не накрывать осветительный прибор в рабочем режиме.

If the external flexible cable or cord of this luminaire is damaged, it shall be exclusively replaced by the manufacturer or his service agent or a similar qualified person in order to avoid a hazard.

Максимальная мощность лампы	(*) 2x 39W	(**) 2x 54W	(***) 2x 80W
Тип цоколя лампы	G5	G5	G5
Тип лампы	T5		
Осветительный прибор КЛАССА I			
Класс защиты	IP20		
пригодный для установки на возгораемых поверхностях	▽		

F

ATTENTION: LA SECURITE DE CET APPAREIL N'EST GARANTIE QUE SI L'ON RESPECTE LES INSTRUCTIONS SUIVANTES. IL EST, PAR CONSEQUENT, INDISPENSABLE DE LES CONSERVER SOIGNEUSEMENT.

AVERTISSEMENTS

Ne jamais couvrir l'appareil pendant son fonctionnement.
Avant d'effectuer toute opération, débrancher la tension de réseau.
Veiller à ne pas dépasser la limite maximale des watts indiquée sur l'appareil.
Cet appareil ne peut pas être utilisé dans des pièces humides ni à l'extérieur.

If the external flexible cable or cord of this luminaire is damaged, it shall be exclusively replaced by the manufacturer or his service agent or a similar qualified person in order to avoid a hazard.

Puissance ampoule.	(*) 2x 39W	(**) 2x 54W	(***) 2x 80W
Culot.	G5	G5	G5
Type ampoule.	T5		
Appareil de classe I			
Classe de protection.	IP20		
Appareil apte au montage sur surfaces normalement inflammables	▽		

P

ATENÇÃO: A SEGURANÇA DO APARELHO É GARANTIDA SOMENTE SE FOREM RESPEITADAS AS INSTRUÇÕES. PORTANTO, É NECESSÁRIO CONSERVÁ-LAS.

ADVERTÊNCIAS

Nunca cobrir o aparelho durante o funcionamento.
Antes de fazer qualquer tipo de operação, desligar a corrente eléctrica da rede.
Prestar atenção para não superar o número de watts indicados para o aparelho.
O aparelho não pode ser utilizado em ambientes húmidos ou no exterior.

If the external flexible cable or cord of this luminaire is damaged, it shall be exclusively replaced by the manufacturer or his service agent or a similar qualified person in order to avoid a hazard.

Potência máxima da lâmpada.	(*) 2x 39W	(**) 2x 54W	(***) 2x 80W
Tipo de suporte da lâmpada.	G5	G5	G5
Tipo de lâmpada.	T5		
Aparelho de CLASSE I			
Classe de protecção.	IP20		
Apropriado para ser montado em superfícies normalmente inflamáveis.	▽		

E

ATENCIÓN: LA SEGURIDAD DEL APARATO ESTÁ GARANTIZADA SÓLO POR UN USO ADECUADO DE LAS SIGUIENTES INSTRUCCIONES; POR CONSIGUIENTE, ES PRECISO CONSERVARLAS.

ADVERTENCIAS

No cubrir jamás el aparato durante el funcionamiento.
Antes de llevar a cabo cualquier tipo de operación, desconectar la tensión de la red.
Prestar atención a no superar el máximo de los vatios indicados en el aparato.
El aparato no podrá utilizarse en ambientes húmedos ni en exteriores.

If the external flexible cable or cord of this luminaire is damaged, it shall be exclusively replaced by the manufacturer or his service agent or a similar qualified person in order to avoid a hazard.

Potencia máxima de la bombilla.	(*) 2x 39W	(**) 2x 54W	(***) 2x 80W
Casquillo de la bombilla.	G5	G5	G5
Casquillo de la bombilla.	T5		
Aparato CLASE I			
Clase de protección	IP20		
Aparato adecuado para el montaje en superficies normalmente inflamables.	▽		

- ① - Procedere al montaggio seguendo le operazioni in ordine numerico progressivo.
- ⒸⒺ - Proceed with assembling following the operations in progressive numerical order.
- Ⓓ - Arbeitsgänge in numerischer ordnung ausführen, um das gerät zu installieren.
- ⒲Ⓤ - Производите установку в порядке увеличения обозначенных выше номеров.
- Ⓕ - Il faut procéder a le montage exècutant les opératoins par l'ordre numerique progressif.
- Ⓟ - Proceder a montagem segundo as istruções em ordem numerica progressiva.
- ⒺⓈ - Proceder al montaje siguiendo las operaciones en orden numerico progresivo.

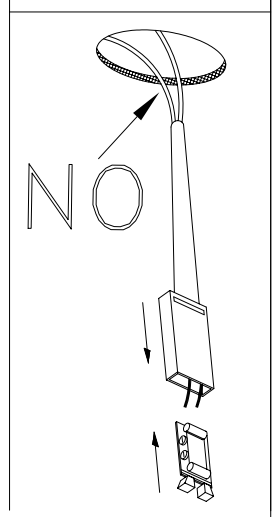
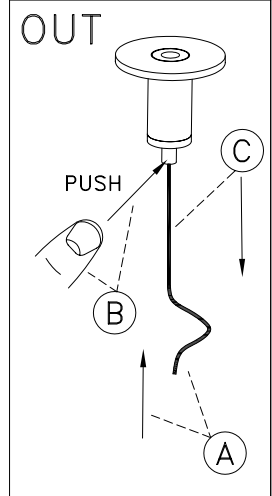
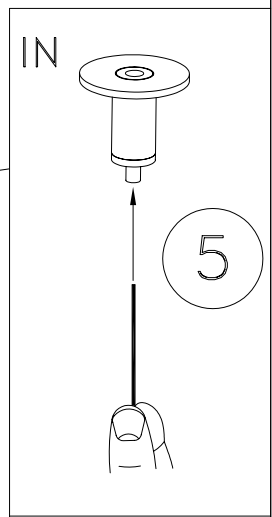
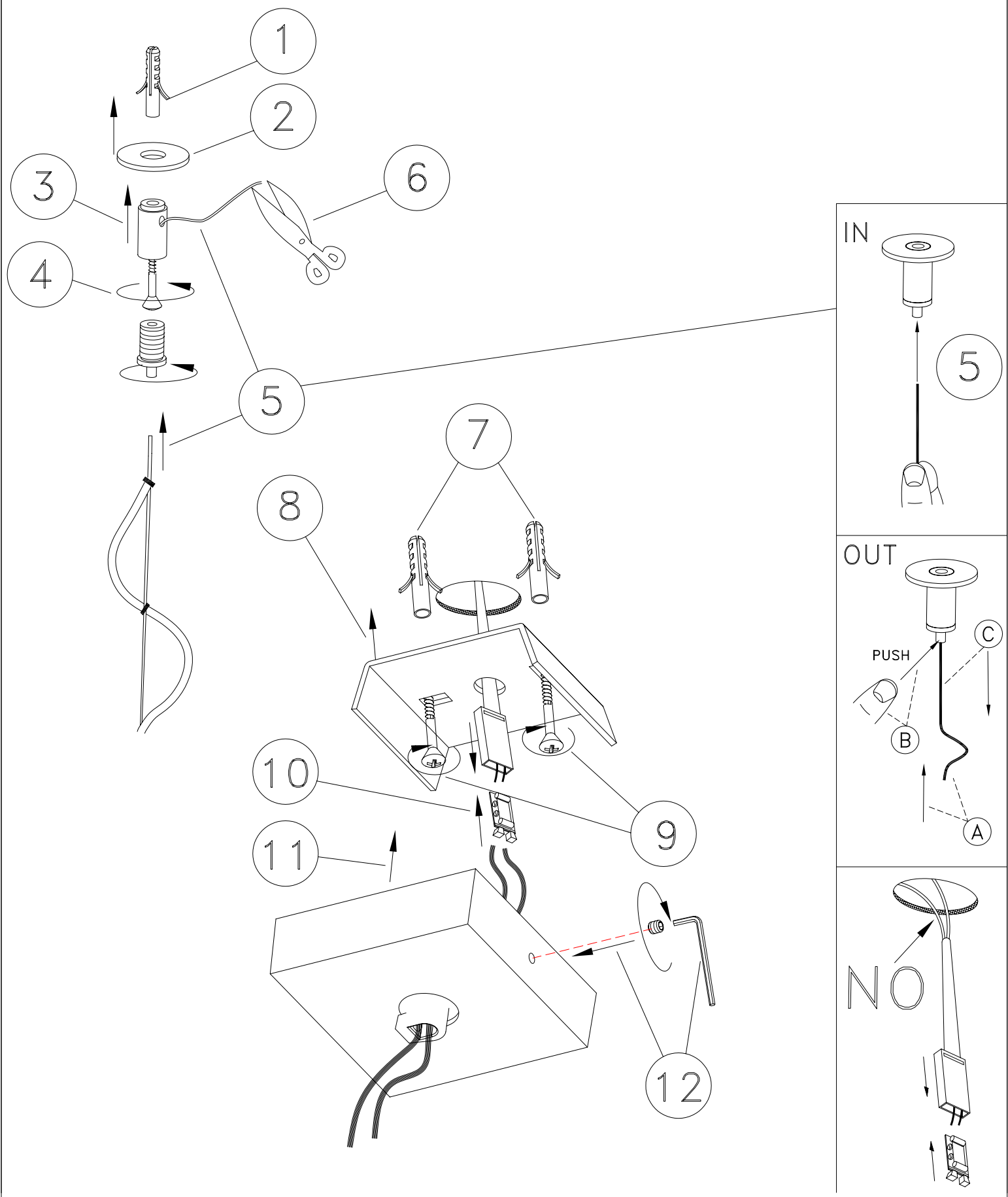

- ① - Procedere al montaggio seguendo le operazioni in ordine numerico progressivo.
- ⒸⒺ - Proceed with assembling following the operations in progressive numerical order.
- Ⓓ - Arbeitsgänge in numerischer ordnung ausführen, um das gerät zu installieren.
- ⒲Ⓤ - Производите установку в порядке увеличения обозначенных выше номеров.
- Ⓕ - Il faut procéder a le montage exècutant les opératoins par l'ordre numerique progressif.
- ⒫ - Proceder a montagem segundo as instruções em ordem numerica progressiva.
- ⒺⓈ - Proceder al montaje siguiendo las operaciones en orden numerico progresivo.

D39 A03-A05-A07

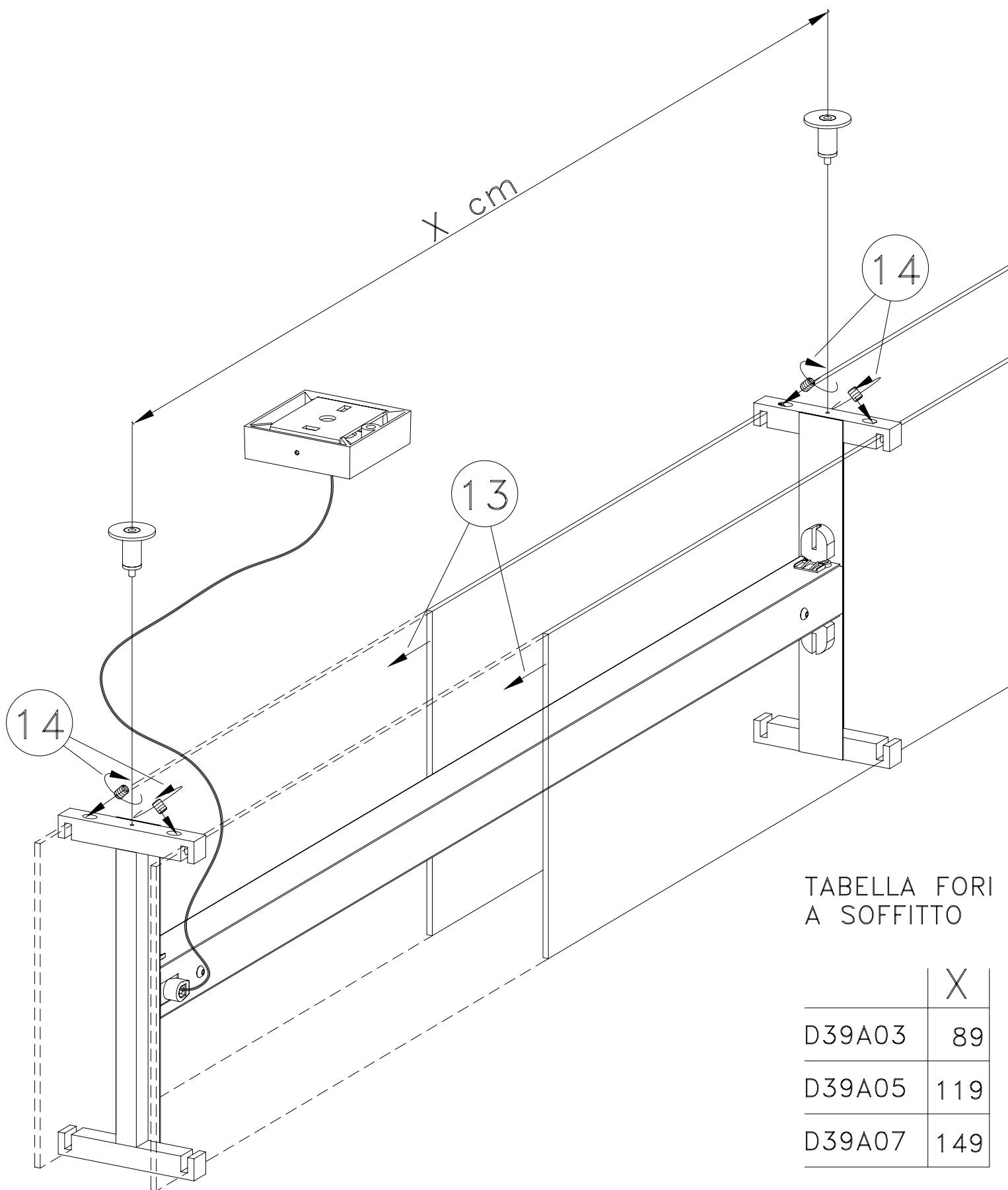

TABELLA FORI
A SOFFITTO

	X
D39A03	89
D39A05	119
D39A07	149