



I

**ATTENZIONE:** LA SICUREZZA DELL'APPARECCHIO È GARANTITA SOLO CON L'USO APPROPRIATO DELLE SEGUENTI ISTRUZIONI. CONSERVARLE CON CURA.  
**AVVERTENZE**

Per la pulizia dei vetri si raccomanda di non usare mai abrasivi o solventi.  
Prima di eseguire qualsiasi tipo di operazione togliere la tensione in rete.  
Fare attenzione a non superare il Max di watt indicati per l'apparecchio.  
L'apparecchio non può essere usato in ambienti umidi o all'esterno.  
Mai coprire l'apparecchio durante il funzionamento.  
Se il cavo flessibile esterno di questo apparecchio viene danneggiato, deve essere sostituito dal costruttore o dal suo servizio di assistenza, o da personale qualificato equivalente.

Potenza massima della lampada.



1x 200W  
Attacco lampada. R7s  
Tipo lampada. QT-DE12  118 mm  
Apparecchio classe II   
Adatto al montaggio su superfici normalmente infiammabili.   
Classe di protezione. IP20

Nel caso di rottura dello schermo di protezione sostituirlo con ricambi originali.

GB

**ATTENTION:** THE SAFETY OF THE APPLIANCE IS GUARANTEED ONLY IF IT IS PROPERLY USED, ACCORDING TO THE FOLLOWING INSTRUCTIONS, WHICH ARE TO BE KEPT.  
**WARNING**

For cleaning the glass do not use any abrasive or solvent materials.  
Always disconnect the power supply before installing or performing any maintenance operations.  
Make attention of not exceeding the maximum watt indicated on the appliance.  
The appliance may not be used in humid or external environments.  
Never cover the appliance while in function.  
If the external flexible cable or cord of this luminaire is damaged, it shall be exclusively replaced by the manufacturer or his service agent or a similar qualified person in order to avoid a hazard.



Capacity of bulb. 1x 200W  
Type of lampholder. R7s  
Type of bulb. QT-DE12  118  
Appliance in class II   
Adaptable for mounting onto surfaces normally inflammable.   
Protection class. IP20

If you break the protection glass, you will change it with originals reciprocations.

D

**ACHTUNG:** DIE SICHERHEIT DIESES BELEUCHTUNGSKÖRPERS WIRD NUR DURCH DIE KORREKTE ANWENDUNG DER NACHSTEHENDEN ANWEISUNGEN GEWÄHRLEISTET. DIESE ÜSSEN DAHER SORGFÄLTIG AUFBEWAHRT WERDEN.  
**WICHTIGE HINWEISE**

Zur Reinigung der Gläser dürfen keine Scheuer- bzw. Lösungsmittel verwendet werden.  
Bevor irgendwelche Arbeitsgänge ausgeführt werden, muß die Stromversorgung unterbrochen.  
Der Beleuchtungskörper darf nicht in feuchten Räumen bzw. im Freien eingesetzt werden.  
Achten Sie darauf, daß die auf dem Beleuchtungskörper angegebene maximale Wattzahl nicht überschritten wird.  
Den Beleuchtungskörper während dem Betrieb nicht abdecken.  
If the external flexible cable or cord of this luminaire is damaged, it shall be exclusively replaced by the manufacturer or his service agent or a similar qualified person in order to avoid a hazard.



Leistung der Gluehbirne. 1x 200W  
Anschluss. R7s  
Typ der Gluehbirne. QT-DE12  118  
Gerat der Klasse II   
Das Gerat eignet sich fuer die Montage auf normal entflammabaren Oberflaechen.   
Schutzklasse IP20

Wenn Sie das Schutzglas brechen, ändern Sie es mit Vorlagen reciprocations.

RU

**ВНИМАНИЕ:** БЕЗОПАСНОСТЬ ОСВЕТИТЕЛЬНОГО ПРИБОРА ГАРАНТИРОВАНА ТОЛЬКО ПРИ УСЛОВИИ ЕГО ЭКСПЛУАТАЦИИ В СООТВЕТСТВИИ С ПРИВЕДЕННЫМИ НИЖЕ ИНСТРУКЦИЯМИ, КОТОРЫЕ НЕОБХОДИМО СОХРАНИТЬ.  
**ВНИМАНИЕ:**

For cleaning the glass do not use any abrasive or solvent materials.  
Перед выполнением любой операции с осветительным прибором отключить напряжение в сети.  
Не превышать максимально допустимую мощность, указанную для данного осветительного прибора.  
Осветительный прибор не может быть использован во влажных помещениях или на улице.  
Никогда не накрывать осветительный прибор в рабочем режиме.  
If the external flexible cable or cord of this luminaire is damaged, it shall be exclusively replaced by the manufacturer or his service agent or a similar qualified person in order to avoid a hazard.



Максимальная мощность лампочки 1x 200W  
Тип цоколя лампочки R7s  
Тип лампочки QT-DE12  118 mm  
Осветительный прибор КЛАССА II   
пригодный для установки на возгораемых   
Класс защиты IP20

If you break the protection glass, you will change it with originals reciprocations.

F

**ATTENTION:** LA SECURITE DE CET APPAREIL N'EST GARANTIE QUE SI L'ON RESPECTE LES INSTRUCTIONS SUIVANTES. IL EST, PAR CONSEQUENT, INDISPENSABLE DE LES CONSERVER SOIGNEUSEMENT.  
**AVERTISSEMENTS**

Ne jamais utiliser des abrasifs ou des solvants pour le nettoyage des parties en verre.  
Avant d'effectuer toute opération, débrancher la tension de réseau.  
Veiller à ne pas dépasser la limite maximale des watts indiquée sur l'appareil.  
Cet appareil ne peut pas être utilisé dans des pièces humides ni à l'extérieur.  
Ne jamais couvrir l'appareil pendant son fonctionnement.  
If the external flexible cable or cord of this luminaire is damaged, it shall be exclusively replaced by the manufacturer or his service agent or a similar qualified person in order to avoid a hazard.



Puissance ampoule. 1x 200W  
Culot. R7s  
Type ampoule. QT-DE12  118 mm  
Appareil de classe II   
Appareil apte au montage sur surfaces normalement inflammables.   
Classe de protection. IP20

Si vous cassez le verre de protection, vous le changerez avec des reciprocations d'originaux.

P

**ATENÇÃO:** A SEGURANÇA DO APARELHO É GARANTIDA SOMENTE SE FOREM RESPEITADAS AS INSTRUÇÕES. PORTANTO, É NECESSÁRIO CONSERVÁ-LAS.  
**ADVERTÊNCIAS**

For cleaning the glass do not use any abrasive or solvent materials.  
Antes de fazer qualquer tipo de operação, desligar a corrente eléctrica da rede.  
Prestar atenção para não superar o número de watts indicados para o aparelho.  
O aparelho não pode ser utilizado em ambientes húmidos ou no exterior.  
Nunca cobrir o aparelho durante o funcionamento.  
If the external flexible cable or cord of this luminaire is damaged, it shall be exclusively replaced by the manufacturer or his service agent or a similar qualified person in order to avoid a hazard.



Potência máxima da lâmpada. 1x 200W  
Tipo de suporte da lâmpada. R7s  
Tipo de lâmpada. QT-DE12  118  
Aparelho de CLASSE II   
Apropriado para ser montado em superficies normalmente inflamáveis.   
Classe de protecção. IP20

Se você quebrar o vidro da proteção, você mudá-lo-á com reciprocations dos originais.

E

**ATENCIÓN:** LA SEGURIDAD DEL APARATO ESTÁ GARANTIZADA SÓLO POR UN USO ADECUADO DE LAS SIGUIENTES INSTRUCCIONES; POR CONSIGUIENTE, ES PRECISO CONSERVARLAS.  
**ADVERTENCIAS**

For cleaning the glass do not use any abrasive or solvent materials.  
Antes de llevar a cabo cualquier tipo de operación, desconectar la tensión de la red.  
Prestar atención a no superar el máximo de los vatios indicados en el aparato.  
El aparato no podrá utilizarse en ambientes húmedos ni en exteriores.  
No cubrir jamás el aparato durante el funcionamiento.  
If the external flexible cable or cord of this luminaire is damaged, it shall be exclusively replaced by the manufacturer or his service agent or a similar qualified person in order to avoid a hazard.

Potencia máxima de la bombilla. 1x 200W  
Casquillo de la bombilla. R7s  
Tipo de bombilla. QT-DE12  118 mm  
Aparato CLASE II   
Aparato adecuado para el montaje en superficies normalmente inflamables.   
Clase de protección. IP20

Si usted rompe el cristal de la protección, usted lo cambiará con reciprocations de las originales.

- Procedere al montaggio seguendo le operazioni in ordine numerico progressivo.
- Proceed with assembling following the operations in progressive numerical order.
- Arbeitsgänge in numerischer Ordnung ausführen, um das Gerät zu installieren.
- Il faut procéder a le montage exécutant les operatoins par l'ordre numerique progressif.

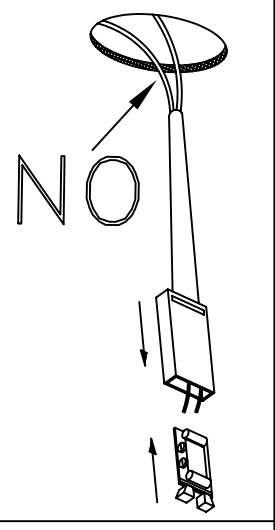
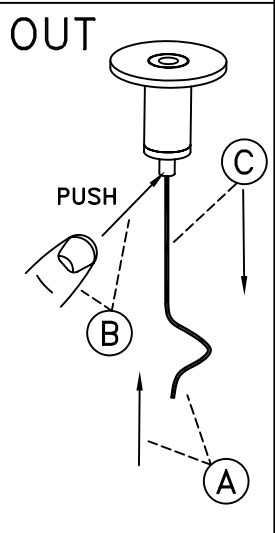
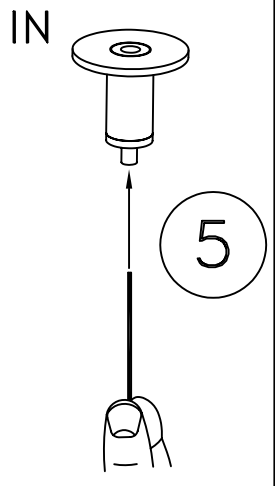
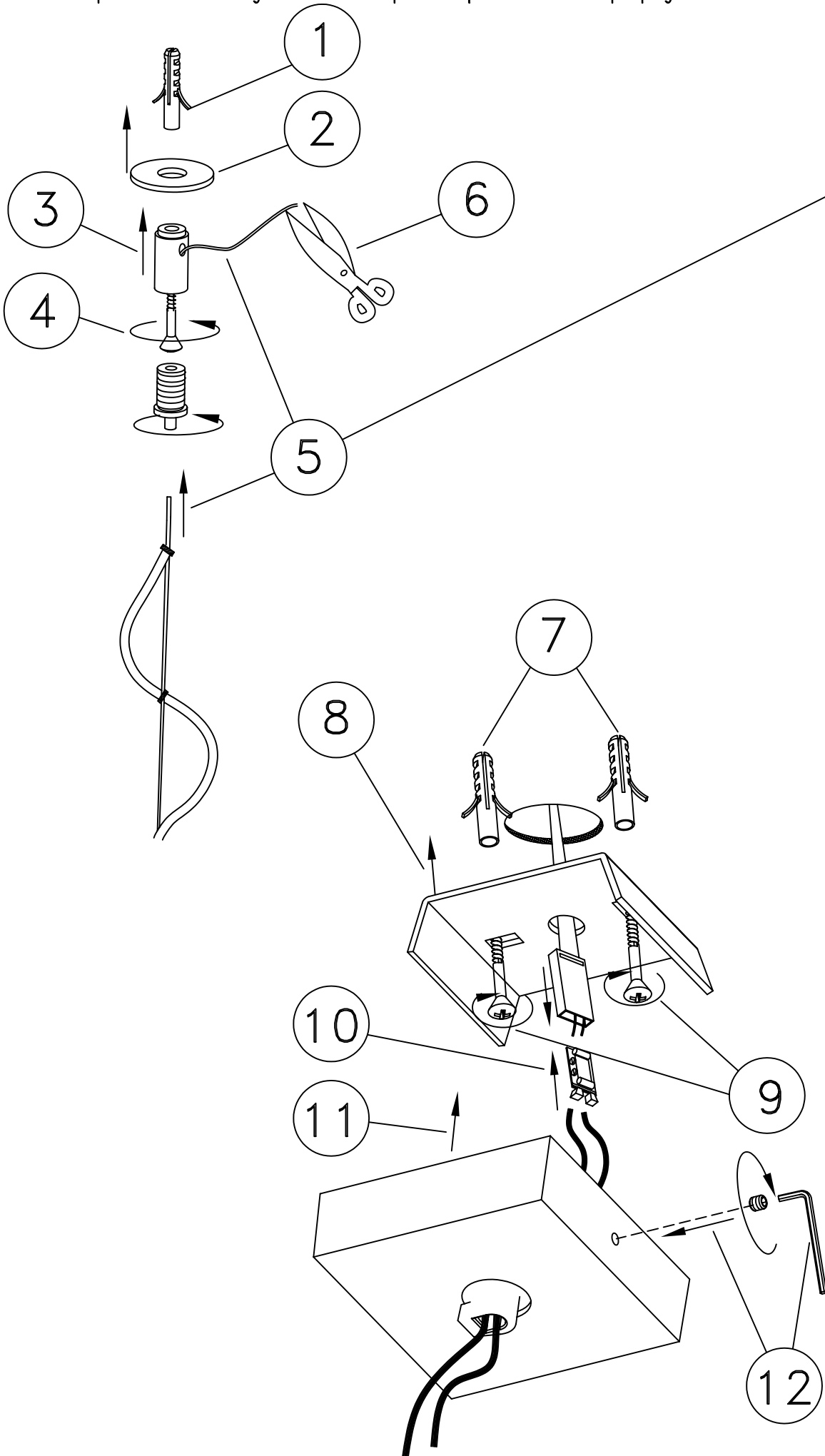

30.5 CM

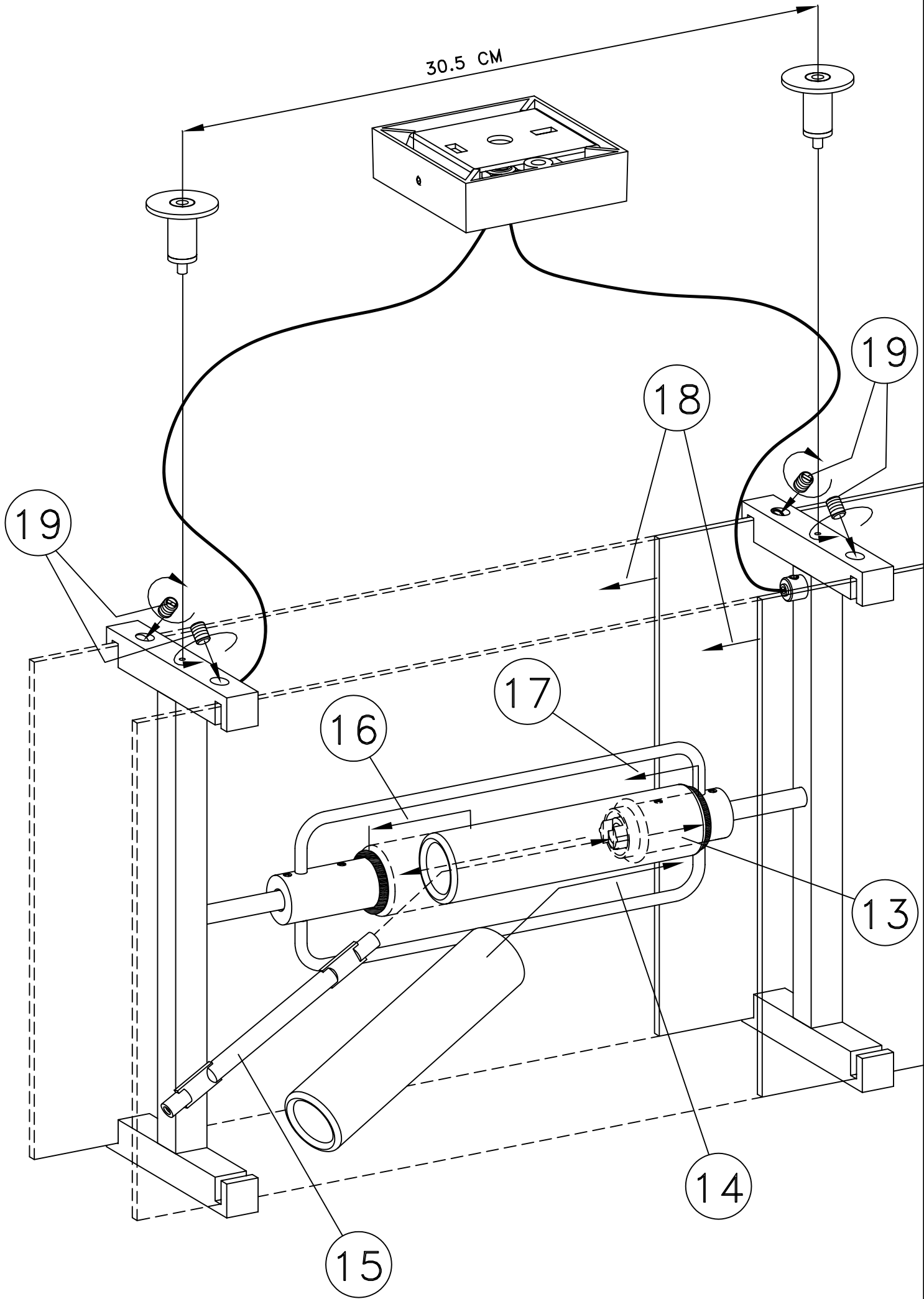

D39A01