

BEGA**50 708.1**

Pendant luminaire for indoor use

Project · Reference number

Date

Product data sheet**Application**

Pendant luminaire · indoor luminaire for free-radiating and uniform light made of hand-blown opal glass, satin matt. Metal luminaire housing.

Product description

Metal luminaire housing,
finish white enamel
Hand-blown opal glass, satin matt
Black flex suspension $2 \times 0,75$ □
Overall length of luminaire approx. 2000 mm
Connecting terminal DA DA for digital control
LED power supply unit inside canopy
220-240 V \sim 0/50-60 Hz
DC 170-280 V
DALI controllable
A basic isolation exists between power cable and control line
Safety class I
CE – Conformity mark

Light technique

Luminaire data for the light planning program DIALux for outdoor lighting, street lighting and indoor lighting as well as luminaire data in EULUMDAT- and IES-format you will find on the BEGA web page www.bega.com.

Lamp

Module connected wattage	13.6 W
Luminaire connected wattage	16.4 W
Rated temperature	$t_a = 25$ °C
Ambient temperature	$t_{a \max} = 50$ °C

50 708.1 K3

Module designation	LED-0405/930
Colour temperature	3000 K
Colour rendering index	CRI > 90
Module luminous flux	2175 lm
Luminaire luminous flux*	940 lm
Luminaire luminous efficiency*	57,3 lm/W

50 708.1 K4

Module designation	LED-0405/940
Colour temperature	4000 K
Colour rendering index	CRI > 90
Module luminous flux	2245 lm
Luminaire luminous flux*	970 lm
Luminaire luminous efficiency*	59,1 lm/W

* preliminary data

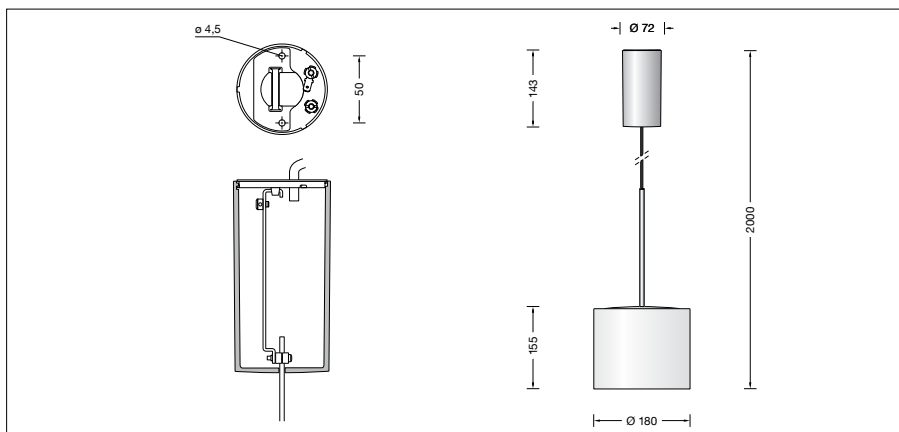
**Lifetime of the LED**

Ambient temperature $t_a = 15$ °C
 – at 50,000h: L90B10
 – at > 500,000h: L70B50

Ambient temperature $t_a = 25$ °C
 – at 50,000h: L90B10
 – at 463,000h: L70B50

max. ambient temperature $t_a = 50$ °C
 – at 50,000h: L80B50
 – at 102,000h: L70B50

Article No. 50 708.1

LED colour temperature optionally 3000 K or 4000 K
 3000 K – Article number + **K3**
 4000 K – Article number + **K4**

Optional finishes

- White enamel
- Stainless steel
- Chrome

code number **.1**
 code number **.2**
 code number **.3**